

Proportional solenoid with inductive transducer for hydraulic application

4

Product group

G RC Y ... A62

Proportional solenoid

- According to DIN VDE 0580
- Armature space pressure-tight, nominal pressure 350 bar statically, nominal operating pressure 210 bar
- To a large extent proportional behaviour between force and current
- Small hysteresis through precise armature bearing
- Quick response times
- Insulation materials of the excitation winding correspond to thermal class F (H available on request)
- Electrical connection and protection class when properly installed:
 - Plug connection by spade connectors according to DIN 46 247
Protection class according to DIN VDE 0470/ EN 60 529 – IP00
 - Plug connection via plug connector according to DIN EN 175 301-803
Screwed cable glands (4 x 90° positions)
Protection class according to DIN VDE 0470/ DIN EN 60529 – IP 65

Inductive transducer

- Frequency limit 500 Hz
- Suitable for dry and pressure-tight applications
- Pressure-tight tube, designed for 350 bar static pressure
- Fastening via threaded pin on intermediale nut
- Electrical connection and protection class when properly installed:
 - Plug connection via surface-mounted plug
Round plug connector M12x1, 4 pole
 - Protection class according to DIN VDE 0470 / DIN EN 60529 – IP 65
- (Electronic) zero adjustment from outside

Application examples

In particular proportional actuator in hydraulic control chains and control loops



Fig. 1: G RC Y 037 N54 A62

Single components

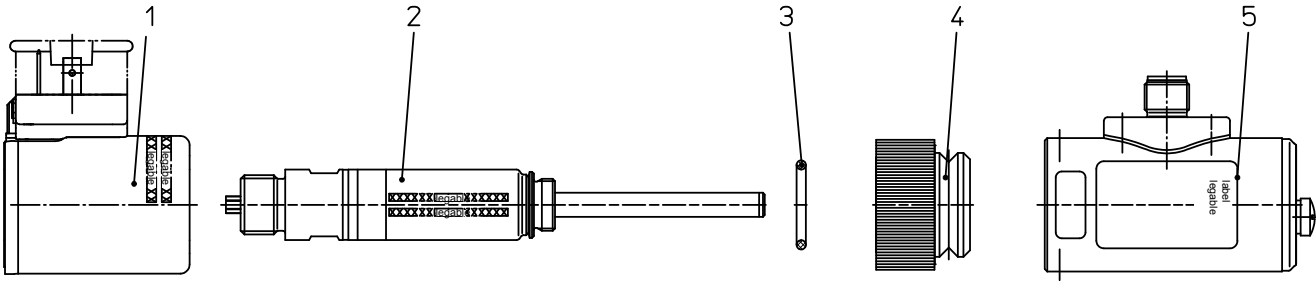

Ser. No.	Qty.	Description
1	1	Magnetic body for 12 or 24 V DC
2	1	Tube
3	1	o-ring 19 x 2,5 70 Sh-A NBR
4	1	Intermediate nut
5	1	Transducer

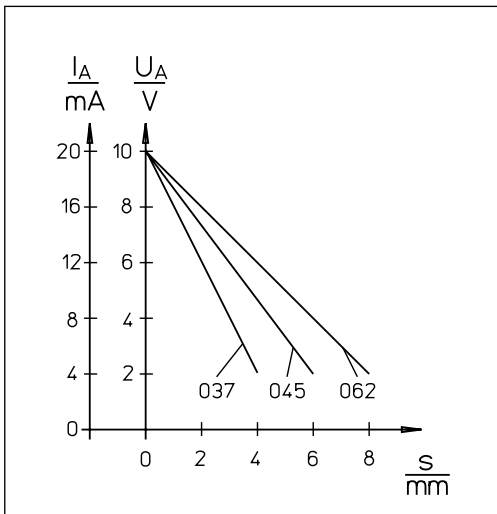

Fig. 2: Current vs. voltage diagram of the transducer

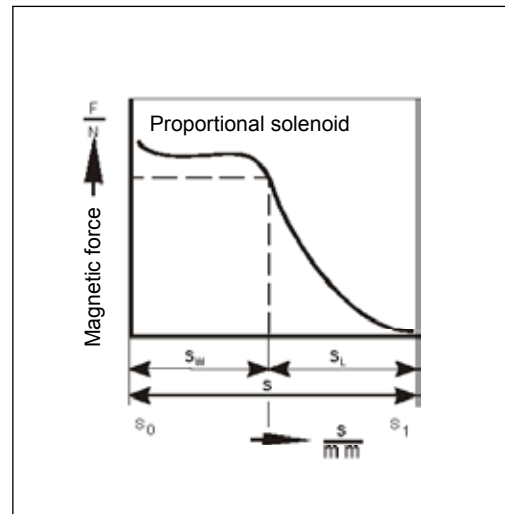

Fig. 3: Force vs. stroke characteristic

Dimension drawings

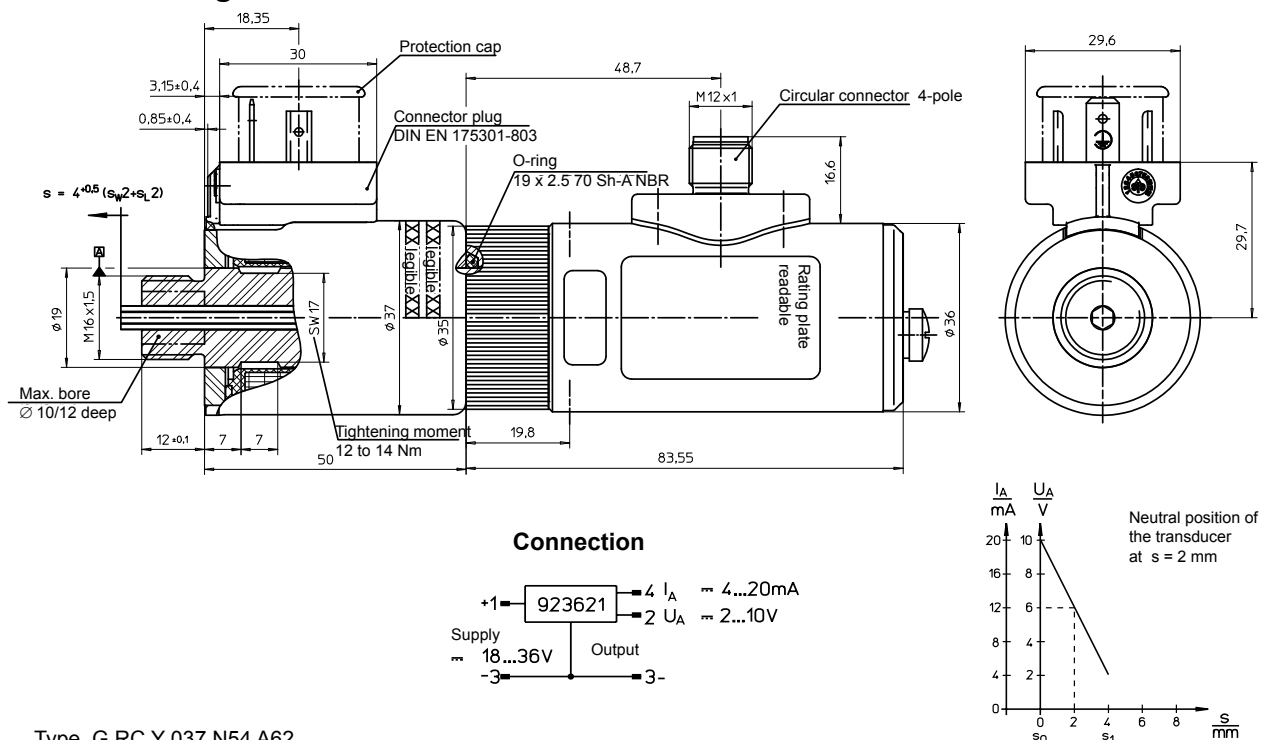

Fig. 4: Type G RC Y 037 N54 A62

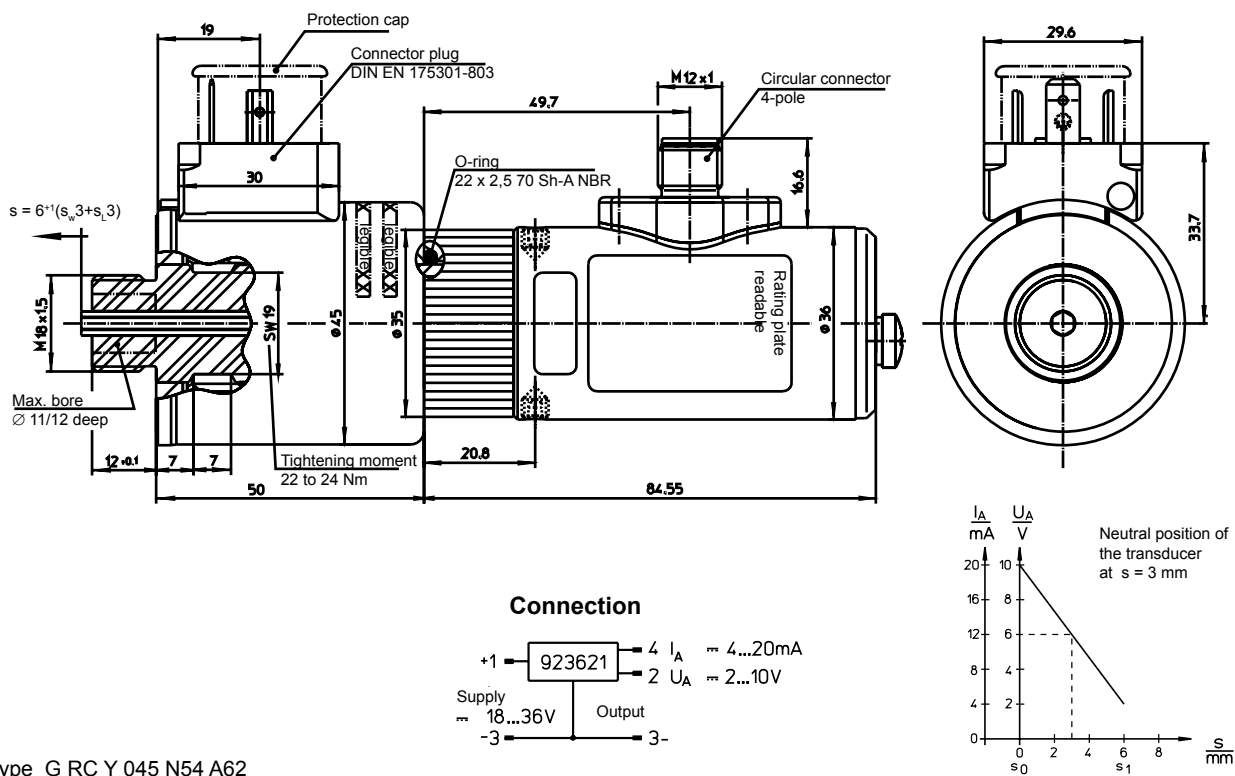

Fig. 5: Type G RC Y 045 N54 A62

Drawing

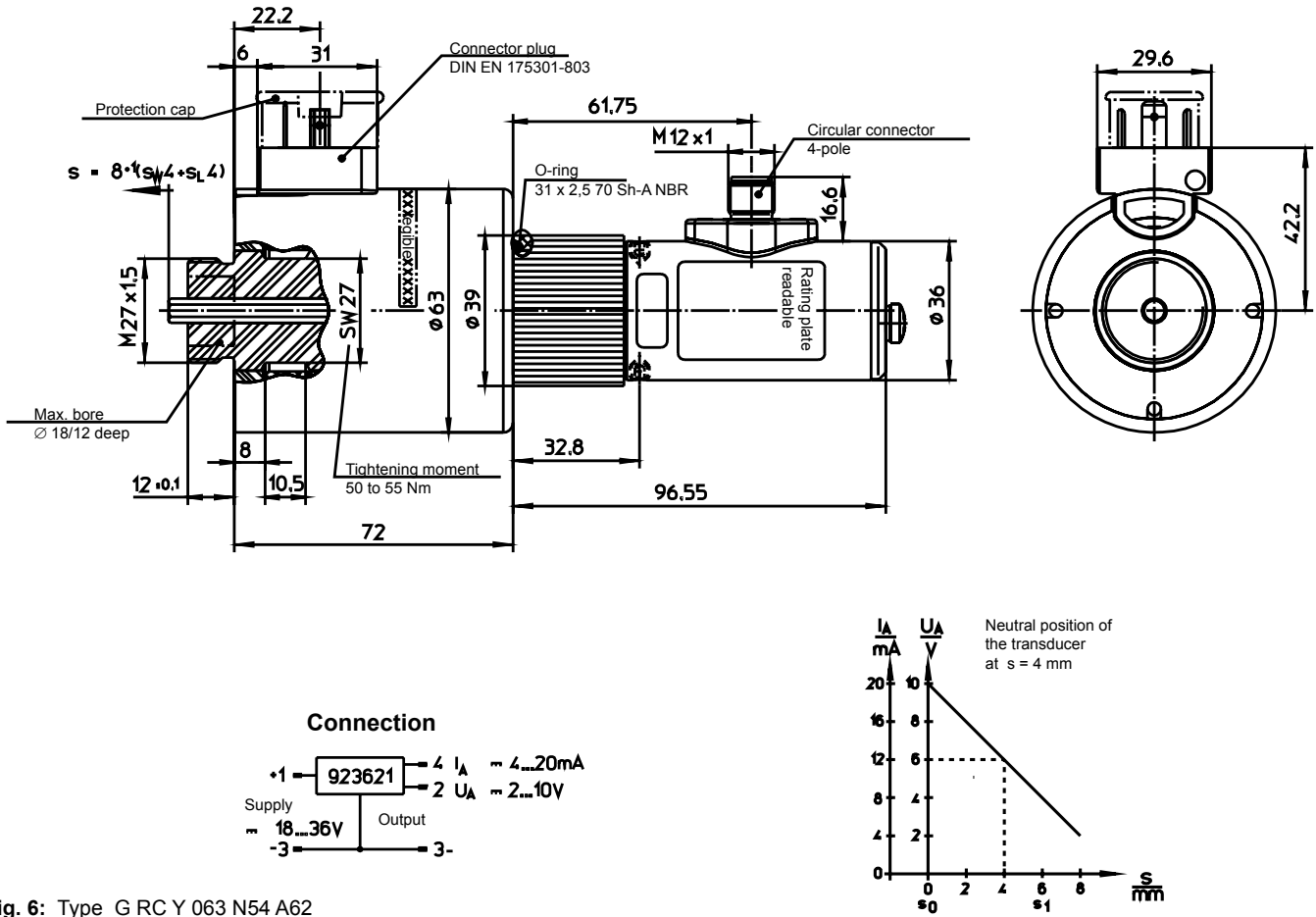
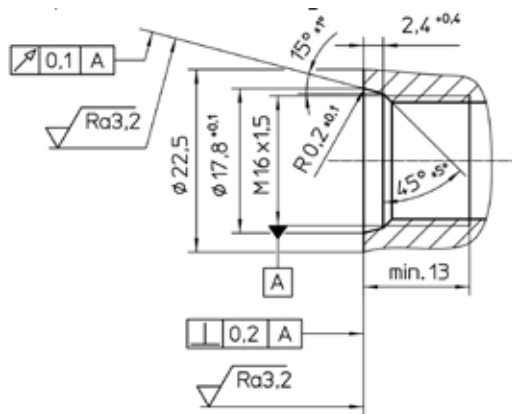

Fig. 6: Type G RC Y 063 N54 A62

Connection geometry

Suitable o-ring 13,3x2,2



Suitable o-ring 15,3x2,2

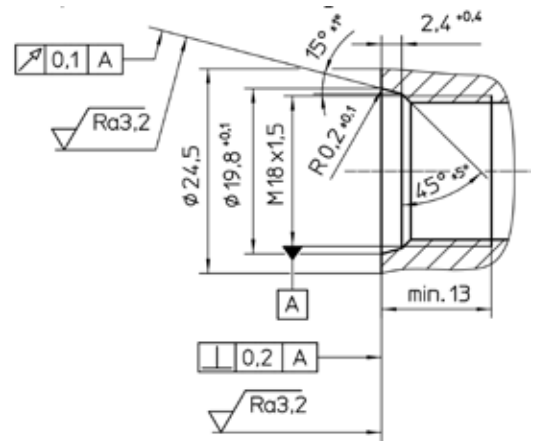

GRCY037N54A62

GRCY045N54A62

Suitable o-ring 24,3x2,2

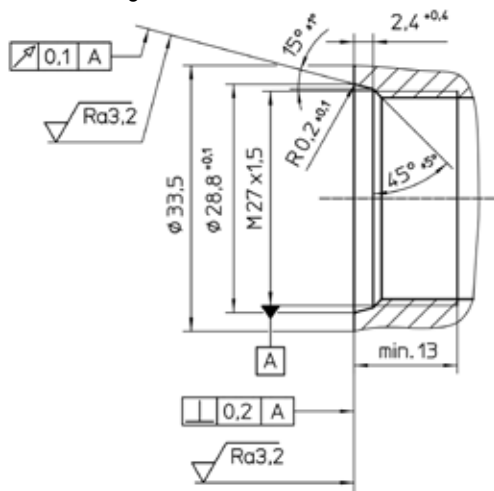

GRCY062N54A62

Combination sensor module with different solenoid sizes

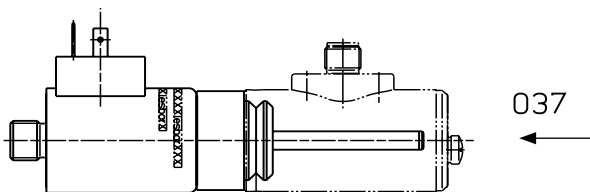
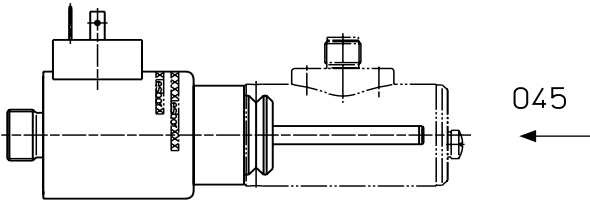
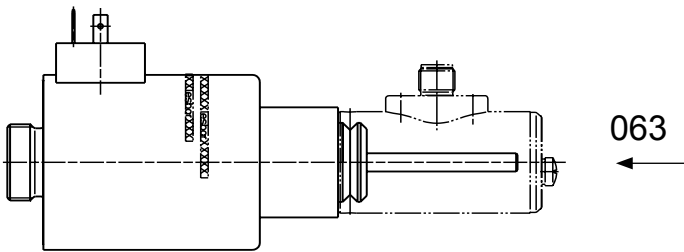
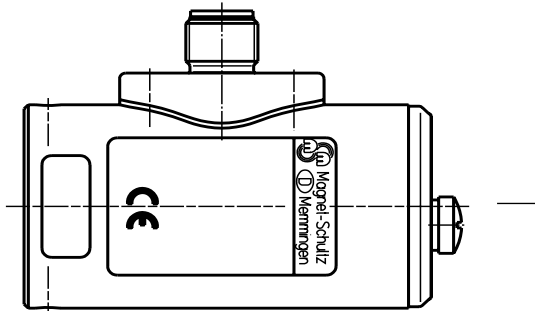

Sensitivity

Sensitivity is the change of the output signal with reference to the change of the measurement path (indicated in V/mm

$\frac{\text{mA}}{\text{mm}}$, resp.).

$$\text{Sensitivity} = \frac{\Delta U}{\Delta s}$$

Linearity error

Linearity error indicates the deviation of the output signal from the ideal straight line in per cent.

$$\text{Deviation}_{\text{Lin}} = \frac{(U_{\text{actual}} - U_{\text{target}})}{U_{\text{voltage stroke}}} \times 100 \%$$

Temperature drift

Temperature drift indicates the deviation in per cent of the output signal per degree of temperature change (shown in % / °K).

$$\text{deviation}_{\text{Temp.}} = \frac{(U_{\text{Temp}} - U_{20^\circ \text{C}})}{U_{\text{voltage stroke}} \times \Delta \vartheta} \times 100 \%$$

The voltage values U may be also replaced by the current values I.

Information and remarks concerning European directives can be taken from the correspondent information sheet which is available under Produktinfo.Magnet-Schultz.com.

Note on the RoHS Directive

According to our current state of knowledge the devices pictured in this document do not contain any substances in concentration values or applications for which putting into circulation with products manufactured from them is prohibited in accordance to RoHS.

Please make sure that the described devices are suitable for your application. Supplementary information concerning its proper installation can be taken also from the  -Technical Explanation, the effective DIN VDE0580 as well as the relevant specifications.

This part list is a document for technically qualified personnel.

The present publication is for informational purposes only and shall not be construed as mandatory illustration of the products unless otherwise confirmed expressively.

Technical data inductive transducer

G RC Y ... N54 A62		037	045	063
Measurement path (mm)		±2	±3	± 4
Supply voltage (== V)		24 ± 10 %		
Current consumption (mA)		< 60		
Sensitivity (V/mm)		2	1.33	1
	(mA/mm)	4	2.66	2
Output voltage (== V)		10 ... 2		
Output current (mA)		20 ... 4		
Linearity tolerance (%)		± 1		
Cut-off frequency (3 dB) (Hz)		typ. 500		
Reference temperature range (°C)		-20 ... + 75		
Temperature drift (% / K)		typ. 0.05		
Load on output voltage (kΩ)		> 5 (short-circuit proof)		
Load on output current (Ω)		< 500		
Declaration of conformity (EMC)		DC 00	DC 00	DC 00
Offset (mm)		± 0,5	± 0.75	± 1

Technical data for proportional solenoids see part list G RC Y 037, 045, 063.

The rated voltage for proportional solenoids is 24 V DC. For actuation as e.g. by electronic servo amplifier an adaptation of the rated voltage has to be respected.

The different sensitivities are achieved by different core lengths in the solenoid tube!

Advantage: One sensor module for all three sizes.

Type code

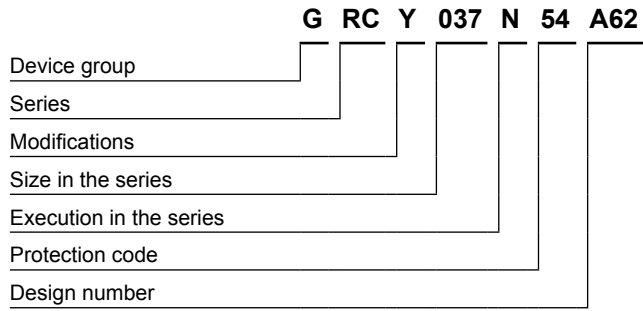

Example

Type	G RC Y 037 N54 A62
Voltage	=== 24 V DC
Operating mode	S1 (100 %)

Specials designs

Please do not hesitate to ask us for application-oriented problem solutions. In order to find rapidly a reliable solution we need complete details about your application conditions. The details should be specified as precisely as possible in accordance with the relevant -Technical Explanations.

If necessary, please request the support of our corresponding technical office.