

VTY10



VTY10, brass



VTY10, plastic

Your advantages

Series	VTY10
	Low wear and extremely long durability due to high quality bearing Practically no deviation in mass production due to fixed pulse rate, insensitive against water hammers, Threaded connection or QuickFasten, proven in numerous mass production applications High measuring accuracy, mostly independent of fitting position due to integrated flow straightener

Technical data	VTY10 threaded	VTY QuickFasten
Material pipe section	Brass	Plastic
Flow range	1...30 l/min	
Accuracy	±1 % of range	
Repeatability	±1 %	
Signal output	From 0.7 l/min	From 0.6 l/min
Medium temperature	0...90 °C (non-freezing)	0...85 °C (non-freezing), temporary 95 °C
Ambient temperature	0...70 °C	
Pressure rating	PN 16	PN 10
Nominal diameter	DN 10	
Process connection	G½ male thread	G¾ male thread
Sensor	Hall effect sensor	
Output signal	Square wave frequency signal, NPN open collector	
Pulse duty ratio	50:50	
Pulse rate / K-factor	495 pulses/l	530 pulses/l
Electrical connection	80 mm (QuickFasten 90 mm) single wire with Molex Mini-Fit® Jr. plug connector (part number 39-01-4036)	
	Optional: PVC-cable (1 m), optional single wires	Optional: Single wires (145 mm)
Power supply	4.5...24 VDC	

Approvals



NSF/ANSI 372
NSF/ANSI 61



Available for:

VY1030MKHNX1A3
VY1030MKHN10A3
VY1030K5HNX1A4
VY1030K5HN10A4

Typical pressure drop

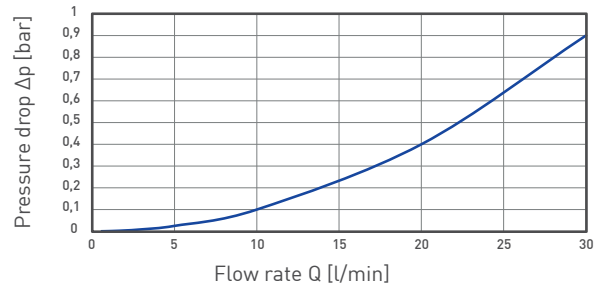

Characteristic curve, plastic

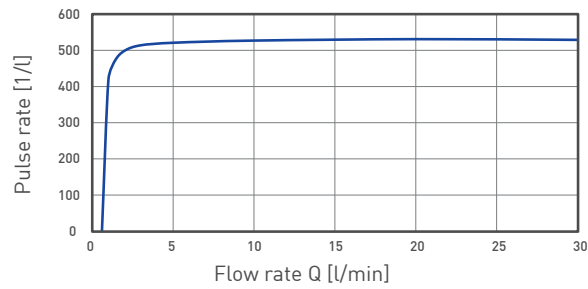

Characteristic curve, brass

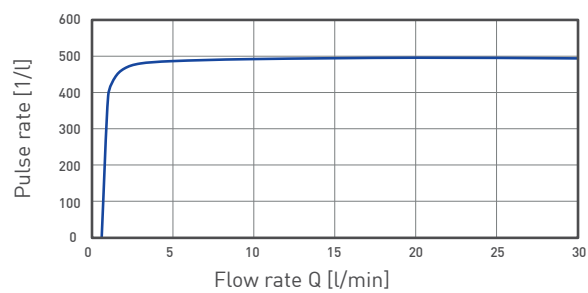

Threaded version, brass

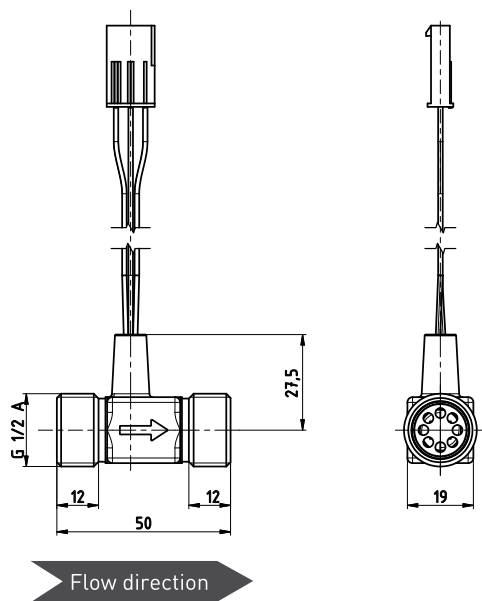

Threaded version, plastic

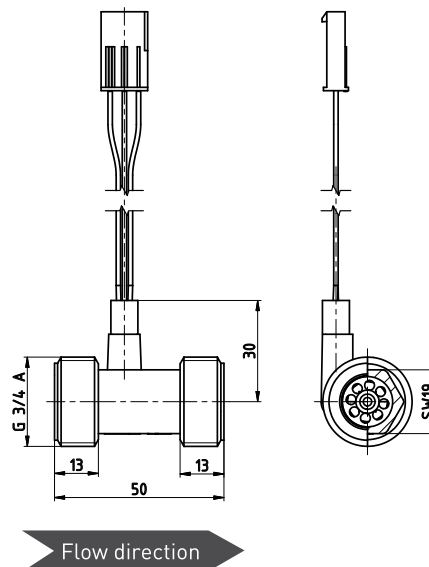

QuickFasten, plastic

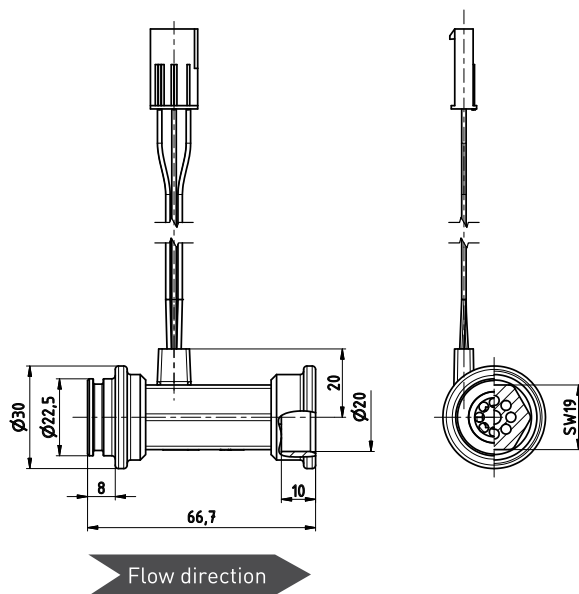

Alternative electrical connection

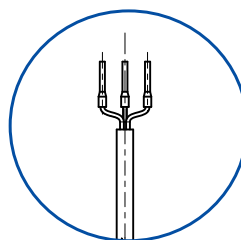

Materials in contact with fluid

Type	VTY10, brass	VTY10, plastic
Pipe section	Brass CW617N	PPE+PS Noryl™ 30 % glass fibre reinforced
Rotor	PPE+PS Noryl™ 30 % glass fibre reinforced	
Magnet	Hard ferrite	
Shaft	Stainless steel / Hard metal	
Axial bearing	Saphir	
Radial bearing	PEEK Victrex™	

Order code		
Type		
VTY10, brass	VY1030MAHN	
Electrical connection		
80 mm single wire with Molex Mini-Fit® Jr. plug connector		X1A3
1 m PVC-cable		10A3
Example order number	VY1030MAHN	X1A3

Order code		
Type		
VTY10, plastic	VY1030K5HN	
Electrical connection		
1 m PVC-cable, threaded		10A4
80 mm single wire with Molex Mini-Fit® Jr. plug connector, threaded		X1A4
145 mm single wires, QuickFasten		P0Q1
90 mm single wires mit with Molex Mini-Fit® Jr. plug connector, QuickFasten		X2Q1
Example order number	VY1030K5HN	10A4

Minimum lot size 100 pieces