

26

Pressostato a taratura fissa
Fixed setting pressure switch

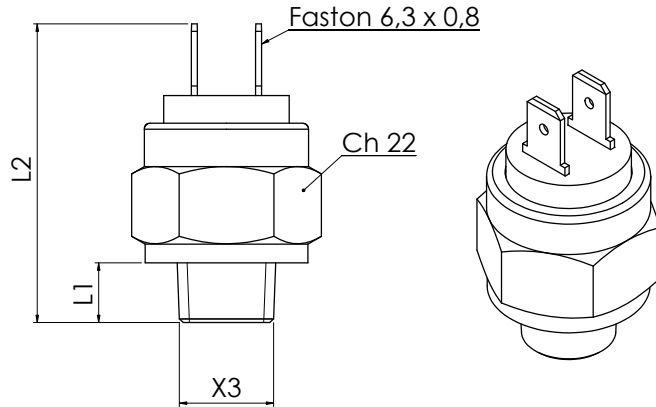

22

Codice - Part Number

| Mod. 26 | | Campo di intervento Operating range | |
|---|-----------|--|--|
| contatto elettrico - electrical contact | | bar | |
| norm. aperto norm. open | | | |
| 26 | 1 0 ● 1 0 | 1 - 4 | |
| 26 | 1 0 ● 1 1 | 3 - 6 | |

| ● Filetti (X3) | Threads (X3) | L1 | L2(mm) | ■ Membrana (vedi pag. 12) | Diaphragm (see page 12) |
|-------------------|--------------------|----|--------|---------------------------|-------------------------|
| 1 1/8" Gas conico | 1 1/8" Gas conical | 8 | 39 | 1 NBR | 1 NBR |
| 2 1/4" Gas conico | 2 1/4" Gas conical | 10 | 41 | | |
| 3 M10x1 conico | 3 M10x1 conical | 9 | 40 | | |

| | |
|---------------------------------------|--|
| Corpo | Acciaio zincato |
| Contatti elettrici | Argentati |
| Condizione elettrica | N.A. |
| Max tensione commutabile | 24 V |
| Max corrente commutabile | 2 A |
| Max temperatura fluido | 100° C |
| Vita meccanica | 10 ⁵ operazioni (0 - 200 bar) |
| Massima pressione di sicurezza | 400 bar |
| Tipo di azionamento | 1B |
| Situazione di inquinazione | grado 2 |
| Peso | ~ 35 gr |

| | |
|--------------------------------|--|
| Case | Zinc plated steel |
| Electric contacts | Silver plated |
| Electric conditions | N.O. |
| Max switched voltage | 24 V |
| Max switched current | 2 A |
| Max fluid temperature | 100° C |
| Mechanical working life | 10 ⁵ operations (0-200 bar) |
| Max Overpressure limit | 400 bar |
| Action type | 1B |
| Pollution situation | grade 2 |
| Weight | ~ 35 gr |

Contattare Euroswitch per maggiori informazioni sulle versioni disponibili

Please contact Euroswitch for further information on the versions available

Per un corretto impiego vedere le note generali del catalogo pressostati Euroswitch edizione 2014.

For a correct use please refer to "General Notes" in the pressure switches Euroswitch catalogue, edition 2014.