

VVX





Your advantages

Series	VVX
	<ul style="list-style-type: none"> No mechanical wear → Flow sensor for liquids with no moving parts Highest strength and performance → Rugged glass fibre reinforced plastic Completely encapsulated piezoceramic sensor to detect the vortices → No direct contact with the medium Wide measuring span (up to 1:21), integrated temperature sensor, high interference resistance, wetted parts metal-free, traceability by serial number, thread connection or QuickFasten

Type	VVX15	VVX20	VVX25
Technical data			
Nominal diameter	DN 15	DN 20	DN 25
Nominal pipe size	½"	¾"	1"
Process connection	G¾-ISO 228 male, incl. O-rings	QuickFasten or G1-ISO 228 male, incl. O-rings	G 1¼-ISO 228 male, incl. O-rings
Process connection	½" NPT	¾" NPT or QuickFasten	1" NPT
Inner diameter [mm]	Ø 13	Ø 19	Ø 25
Inner diameter [inch]	0.5	0.75	1
Flow range [l/min]	2...40	5...80	7...150
Flow range [US gpm]	0.5...10	1.3...21	2...40
Accuracy	±2 % of range*, deviations with media of higher viscosity		
Repeatability	±0,5 % or ±1 %, see temperature ranges ambient		
Medium	Water and aqueous solution		
Pressure rating	PN 10		
Pressure rating	Max. 145 psi		
Degree of protection EN 60529	IP65** and IP67**		

* Test conditions:
 → Test medium water
 → Media temperature 20...30 °C / 68...86 °F
 → Inlet pressure 7...10 bar / 102...145 psi
 → Defined inlet and outlet pipes (see operating manual)

** With attached cable socket only

Type	VVX15	VVX20	VVX25
Temperature ranges			
Medium	5...90 °C, -20...90 °C*		
Medium	41...194 °F, -4...194 °F*		
Ambient	5...70 °C → Repeatability ±0,5 %, -20...5 °C → Repeatability ±1 %		
Ambient	41...158 °F → Repeatability ±0.5 %, -4...158 °F → Repeatability ±1 %		
Electrical data			
Electrical connection	5-pin plug connector M12 x 1		
Power supply	8...30 V DC: PushPull (optional NPN) 5 V DC: NPN 12...24 V DC: 4...20 mA or 0...10 V		
Current consumption	< 15 mA		
Approvals			
	WRAS pending		
	 <ul style="list-style-type: none"> • Conforms to ANSI UL Std.61010-1 • Cert. to CAN/CSA C22.2 No.61010-1 		 <ul style="list-style-type: none"> • Conforms to ANSI UL Std.61010-1 • Cert. to CAN/CSA C22.2 No.61010-1
	ETL only available for version with frequency output and version with analog output (0.5...3.5 V) and frequency output		

* Temperature cycle test: -20 °C / 70 °C / -4 °F / 158 °F, 0 % rH, cycle time 1.5 h, temperature gradient approx. 2.5 K/min, hold time at -20 °C / -4 °F and 70 °C / 158 °F 10 min each, 90 cycles: no failures

Three different versions available:

- Frequency output (1)
- Analogue 0.5...3.5 V and frequency output (2)
- Analogue 0...10 V or 4...20 mA and frequency output (3)

Frequency output (1)	VVX15	VVX20	VVX25
Output signal flow	Frequency signal, square wave, pulse duty ratio 50:50, signal current max. 20 mA		
Pulse rate [1/l]	500 (optional 3...1000)	200 (optional 2...800)	100 (optional 1...500)
Pulse rate [pulses/gallon]	2000 (optional 12...4000)	750 (optional 8...3000)	400 (optional 4...2000)
Output signal temperature	Pt1000 2 wire, class B or NTC 10.74k, B 0/100 3450 or none		

Analogue output (2)	VVX15	VVX20	VVX25
Output signal flow	0.5...3.5 V		
Scaling [l/min]	2...40	5...80	7...150 l/min
Scaling [US gpm]	0.5...10	1.3...21	2...40 GPM
Voltage rate → 0.5...3.5 V	0.07895 V / l/min	0.04000 V / l/min	0.02098 V / l/min
Voltage rate [V / US gpm] → 0.5...3.5 V	0.31579	0.15228	0.07895
Output signal temperature	Voltage signal 0.5...3.5 V corresponds to 0...90 °C / 32...194 °F or none		

Analogue output (3)	VVX15	VVX20	VVX25
Output signal flow	0...10 V or 4...20 mA		
Scaling [l/min]	0...40	0...80	0...150
Scaling [US gpm]	0...10	0...21	0...40
Voltage rate [V / l/min] → 0...10 V	0.25000	0.12500	0.06667
Current rate [mA / l/min] → 4...20 mA	0.40000	0.20000	0.10667
Voltage rate [V / US gpm] → 0...10 V	1.00000	0.47619	0.25000
Current rate [V / US gpm] → 4...20 mA	1.60000	0.76190	0.40000

VVX20 QuickFasten

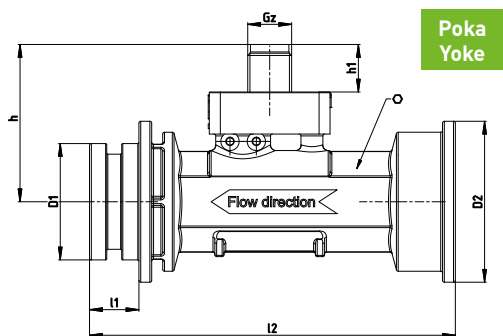

VVX threaded versions

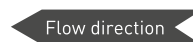
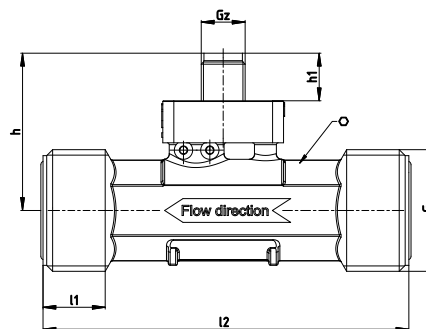

NPT version

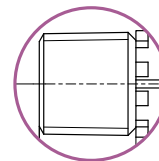

Dimensions [mm]	h	h1	D1	D2	l1	l2	G	Gz	○ Width across flats
Threaded version									
VVX15	40	13			16.5	80	G 3/4	M12 x 1	19
VVX20	43	13			16.5	100	G 1	M12 x 1	24
VVX25	46	13			16.5	95	G 1 1/4	M12 x 1	30
Quickfasten									
VVX20	43	13	31.8	44	13.5	100		M12 x 1	24
Dimensions [inch]									
Threaded version									
VVX15	1.57	0.51			0.79	3.45	1/2 - 14 NPT	M12 x 1	7.48 and 15/16"
VVX20	1.69	0.51			0.81	3.94	3/4 - 14 NPT	M12 x 1	9.45 and 1 1/8"
VVX25	1.69	0.51			0.53	3.94	1 - 11.5 NPT	M12 x 1	11.81 and 1 1/2"
Quickfasten									
VVX20	1.81	0.51	1.25	1.73	0.94	3.94			

Materials in contact with media

VVX15, VVX20, VVX25

Body /tube	PPS Fortron® 40 % glass fibre reinforced
Sensor	ETFE Tefzel®
O-rings	EPDM

Typical pressure drop VVX15

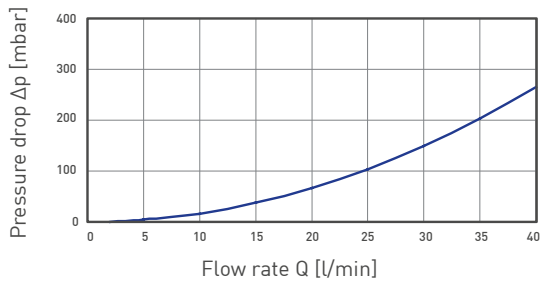

Typical pressure drop VVX15

US version

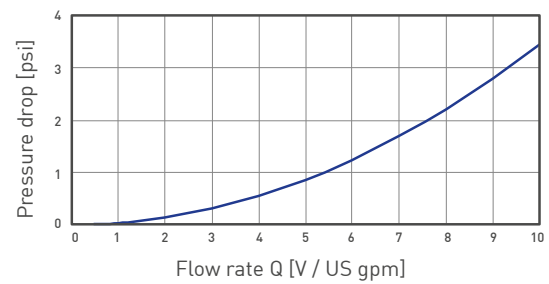

Typical pressure drop VVX20

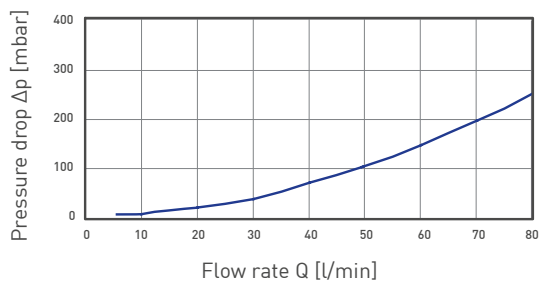

Typical pressure drop VVX20

US version

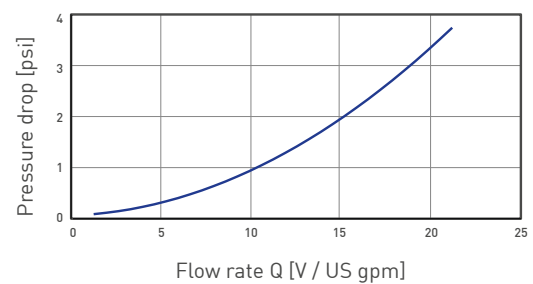

Typical pressure drop VVX25

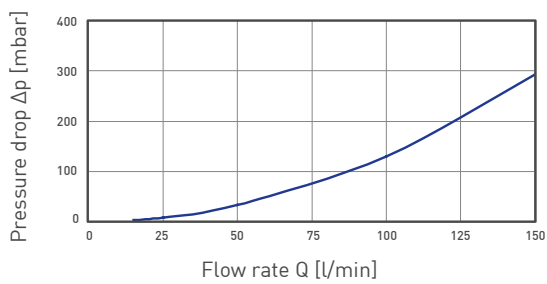

Typical pressure drop VVX25

US version

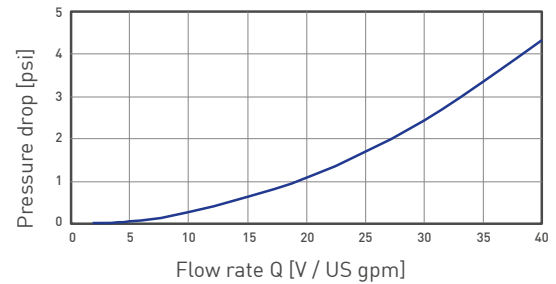

Version frequency output

Order code							
Nominal diameter							
DN 15	VXA1S		A			514	
DN 20 QuickFasten	WXC9S		B			52P	
DN 20 G1	WXC9S		B			527	
DN 25	WXB2S		B			516	
Power supply							
8...30 V DC		G			1		
5 V DC		N			2		
Output signal temperature							
Pt1000				RRRP			
NTC 10.74K				RRRN			
None				0000			
Example order number		VXA1S	G	A	RRRP	1	514

BEST
SELLER

Type		Order number					
VVX15	DN 15, power supply 8...30 VDC, output signal temperature Pt1000	VXA1S	G	A	RRRP	1	514
VVX20	DN 20 G1, power supply 5 VDC, without output signal temperature	WXC9S	N	B	0000	2	527
VVX25	DN 25, power supply 8...30 VDC, output signal temperature Pt1000	WXB2S	G	B	RRRP	1	516

Order code							
Nominal pipe size							
1/2"	VXAAE		1			51C	
3/4" QuickFasten	WXCCS		K			52P	
3/4"	WXCCS		K			528	
1"	WXBBE		2			51E	
Power supply							
8...30 V DC		G			1		
5 V DC		N			2		
Output temperature sensor							
Pt1000				RRRP			
NTC 10.74K				RRRN			
None				0000			
Example order number		VXAAE	N	1	RRRP	1	51C

Version analogue output (0.5...3.5 V) and frequency output

Order code					
Nominal diameter					
DN 15	WXA1SNA	U1			514
DN 20 QuickFasten	WX9SNB	UC			52P
DN 20 G1	WX9SNB	UC			527
DN 25	WXB2SNB	U2			516
Output signal temperature					
0.5...3.5 V			U1		
none			00		
Power supply					
8...30 V DC				1	
5 V DC				2	
Example order number	VVXA1SNA	U1	U1	1	514

Order code					
Nominal pipe size					
1/2"	WXAAEN1UA				51C
3/4" QuickFasten	WXCCSNKUE				52P
3/4"	WXCCSNKUH				528
1"	WXBBEN2UB				51E
Output temperature sensor					
0.5...3.5 V			U1		
None			00		
Power supply					
8...30 V DC				1	
5 V DC				2	
Example order number	VVXAAEN1UA	U1	1	1	51C











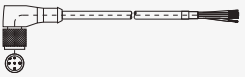

Version analogue output (0...10 V or 4...20 mA) and frequency output

Order code		
Nominal diameter		
DN 15	VXA1SGA	K003514
DN 20 QuickFasten	WXC9SGB	N00352P
DN 20 G1	WXC9SGB	N003527
DN 25	WXB2SGB	L003516
Output signal flow		
0...10 V	V	
4...20 mA	A	
Example order number	VVXA1SGA V	K003514

BEST
SELLER

Type	Order number
VVX15 DN 15, output signal flow 4...20 mA	VVXA1SGA A K003514
VVX20 DN 20 G1, output signal flow 4...20 mA	VVXC9SGB A N003527
VVX25 DN 25, output signal flow 4...20 mA	VVXB2SGB A L003516

Order code		
Nominal pipe size		
1/2"	VXAASN1	P00351C
3/4" QuickFasten	WXCCSNK	Q00352P
3/4"	WXCCSNK	Q003528
1"	WXBBSN2	S00351E
Output signal flow		
0...10 V	V	
4...20 mA	A	
Example order number	VVXAASN1 V	P00351C

Order code					
Type	Accessories		Length [m]	Length [ft]	Order number
VVX15		Connection cable with 5 pin cable socket M12 x 1, angle type molded lead 5 x 0.34 mm ² , sheathing material PVC (Tmax = 80 °C / 176 °F)* <i>UL approval</i>	1		XVX040
VVX20			2		XVX051
VVX25			3		XVX039
			5		XVX041
			10		XVX042
				16	XVX018
				33	XVX019
		Connection cable with 5 pin cable socket M12 x 1, molded lead 5 x 0.34 mm ² , sheathing material PVC, 4 pin Molex MicroBlade wire-to-board housing, (Tmax = 80 °C / 176 °F)	1.5	10	XVX065
Type	Accessories		Order number**		Order number**
VVX15		Screw coupling G 1/2, brass	BWV1007		
		Soldering coupling Ø 15 mm, brass	BWV1008		
VVX20		O-ring for QuickFasten, EPDM	XVX061		XVX061
		Joint clip QuickFasten, stainless steel	XVX052		XVX052
		Soldering coupling for QuickFasten, inlet side	BWV1012		BWV1012
		Soldering coupling for QuickFasten, outlet side	BWV1011		BWV1011
		Screw coupling G 1***, brass, compatibility type	BWV1021		
VVX25		Screw coupling R1, brass	BWV1003		
		Soldering coupling Ø 28 mm, brass	BWV1004		
		Bonding coupling Ø 25 mm, PVC	BWV1005		
		Screw coupling G 1, stainless steel 1.4571	BWV1006		
		Screw coupling G 1 1/4***, brass, compatibility type	BWV1022		

* Connection cable with UL approval on request

** Supplied piecewise

*** Two pieces are required for the assembly

