

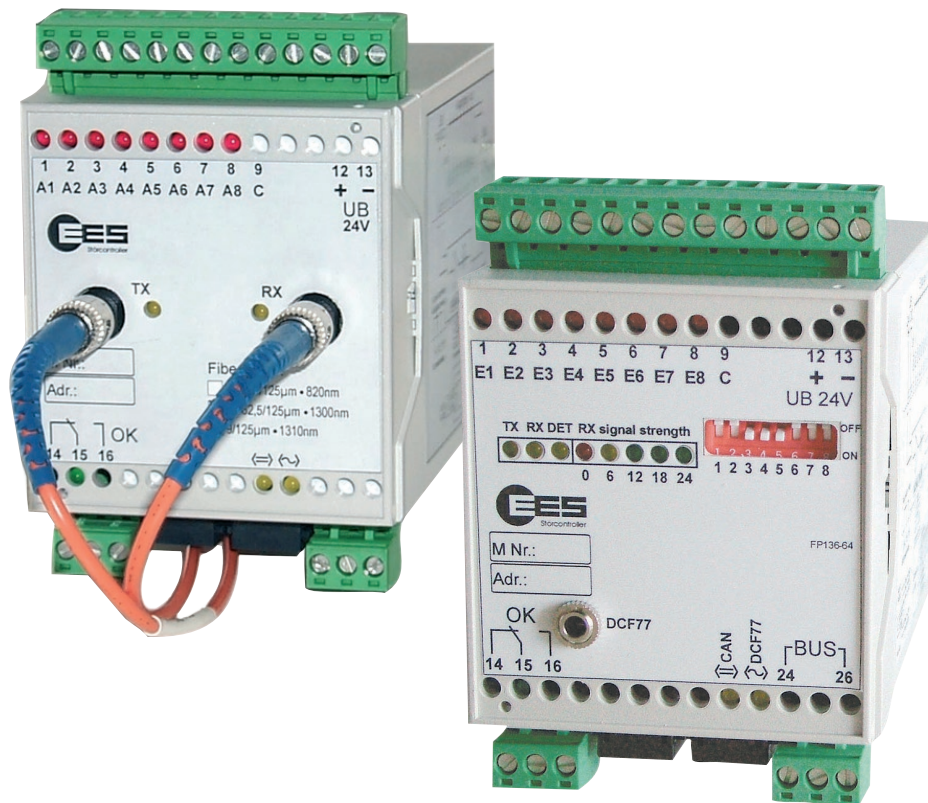

# Speed-optimised point-to-point telecontrol systems



## ➔ Speed-optimised design for dedicated line or optical fibre

- › Fault-free, rapid bidirectional point-to-point data transmission
- › Dedicated line signal delays typically 200 ms respectively 500 ms or with optical fibre signal delays < 100 ms
- › Integrated diagnosis tools
- › DIN rail mounting
- › Modular upgrading, basic module with expansion modules
- › Simple parameterisation of modules via DIP switch

➔ [Data sheet](#)

## → System description

---

The modular telecontrol network MFW is characterised by a flexible, modular concept, which can use all available media for data transmission such as telephone connections (landline, GSM, GPRS), DC cables, cable screens, electrically isolated cables, fibre optics and various radio ranges.

In some cases (e.g. intertripping of railway traction substations), instead of the total complexity of the system, a special speed optimised variant for the application is required. For this requirement the MFW systems have been perfected for the transmission media dedicated line and fibre optics at high transmission speed between a point-to-point connection. The parameterisation of the system is achieved by simple operation per DIP switches.

In each station at least one basic module designed as master module – designated in the type description “MF-...” - is required. At the minimum extension the telecontrol system consists of one of these basic modules and an expansion module in each station. This includes the following function groups, display and setting elements:

- Internal modem (dedicated line or fibre optics)
- RS 232 service and diagnostic interface
- I/O -component with 8 binary outputs
- 2 CAN-Bus interfaces for connection of expansion modules
- Watchdog LED and fault signalling contact for self-monitoring
- DIP switch for setting of module number etc.

The data range of the basic module can be increased by expansion modules which can be connected on the two CAN bus interfaces. How many expansion modules are connectable at each stations is dependent on the referring design variant.

The system constantly monitors the data connection. In the event of a fault the system reports this in both stations via LED and relay contact. Via the serial RS232 diagnosis interface of the basic module it is possible to query additional diagnosis data (error codes, transmission quality etc.) per terminal program.

## → Optical fibre

---

The use of fibre optics as transmission media ensures a robust fault-free transmission over long distances. There are three types available for the connection of the different fibre optic types:

1. Multi-mode fibres with 50/125 µm or 62.5/125 µm core sleeve diameter, wavelength 1300 nm
2. Single mode glass fibres with 9/125 µm core sleeve diameter, wavelength 1310 nm
3. Multi-mode fibres with 50/125 µm or 62.5/125 µm core sleeve diameter, wavelength 820 nm

In all designs plug connectors of the ST® (BFOC/2,5 acc. to standard IEC 60874-10) type are used.

The distance which can be bridged depends on the used optical fibre type, on the plugs and on the splice losses and can amount to up to 22 km. The system can be switched between unidirectional and bidirectional operation. For each transmission direction an individual fibre optic is used.

In the minimum design the speed optimised optical fibre telecontrol system consists in each station of a basic module with digital outputs and inputs. This minimum system can be extended with the expansion modules for the following maximum signal range per side:

- 24 digital inputs (therefrom 8 counter values)
- 24 digital outputs (therefrom 8 counter values)
- 4 analog inputs
- 4 analog outputs

**Terminal assignments and dimensional drawing**

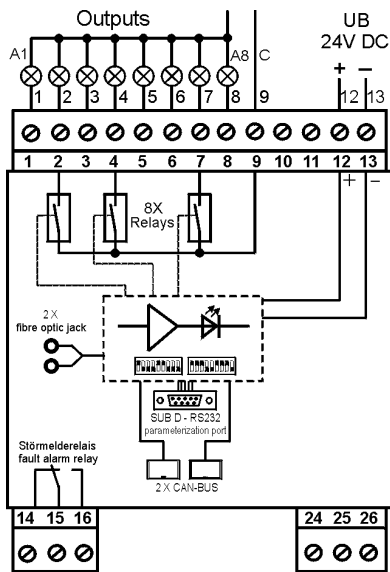

Basic module with fibre optic modem and 8 output relays

**Basic MFW module with fibre optic modem**

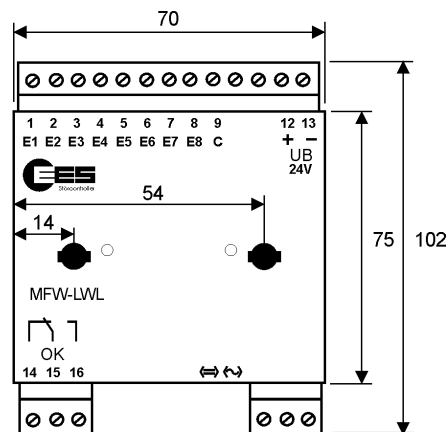
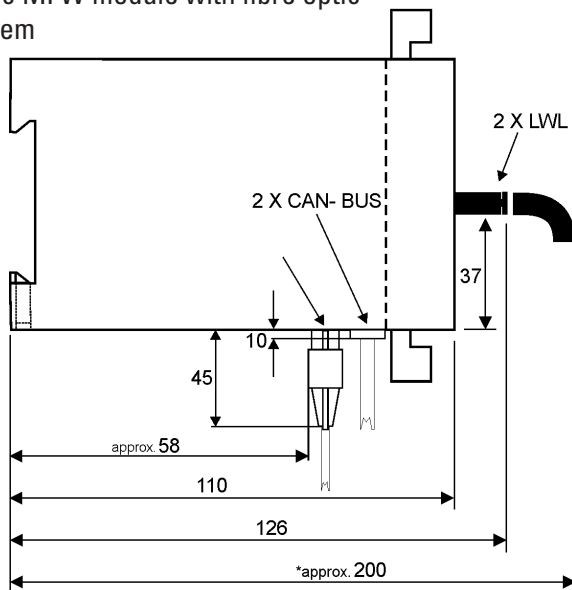

**\*Note! Necessary installation depth:**  
Consider the minimum bending radius of the fibre optic used!

Dimensions in mm  
The right to make technical changes is reserved

## → Dedicated line

### Basic variant

For the speed-optimised dedicated line telecontrol system there is in each station one basic module with 8 relay outputs and one expansion module with 8 digital inputs required.

 In this way the bidirectional transmission of 8 digital signals is possible. Counter values and analog values cannot be transmitted.

### Extended variant

In the extended dedicated line variant additionally expansion modules can be switched on for the following maximum signal scale:

- 24 digital inputs (therefrom 8 counter values)
- 24 digital outputs (therefrom 8 counter values)
- 4 analog inputs
- 4 analog outputs

 Due to the higher data traffic the signal delay of the extended variant is greater in comparison to the basic variant.

### Terminal assignment

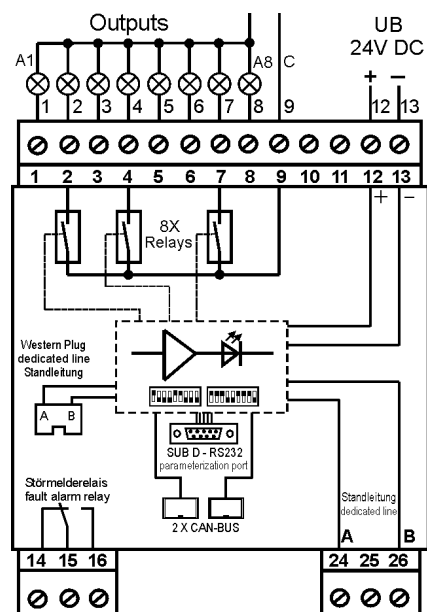

Basic module with dedicated line modem and 8 output relays

MFW basic module with dedicated line modem

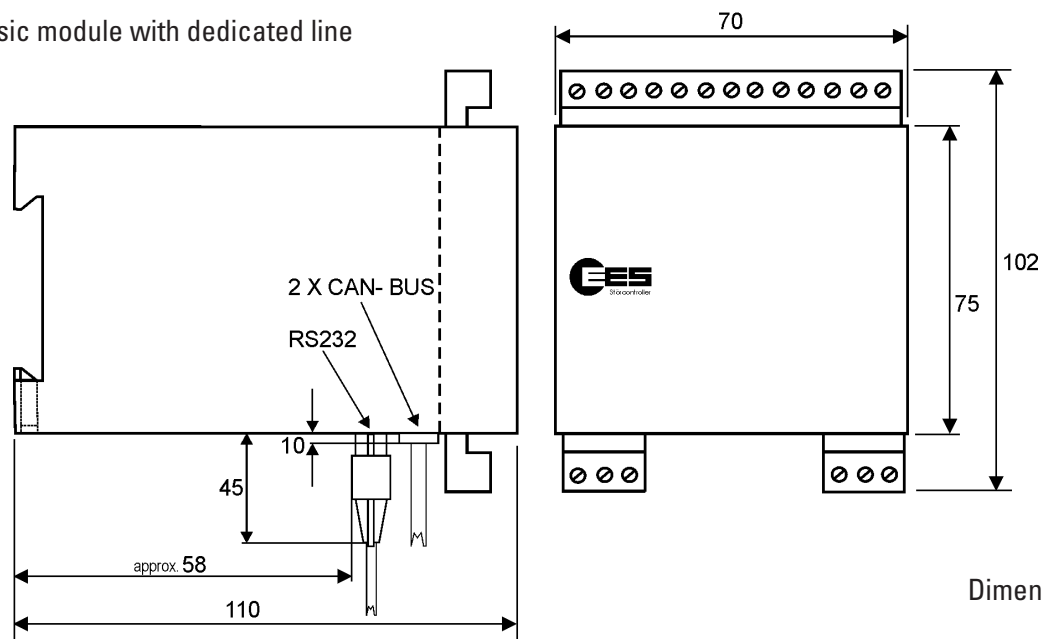

Dimensions in mm

## → Expansion module

The connection of the expansion modules is achieved via a bus cable as supplied to one of the two CAN bus sockets. The power supply of the modules is provided via the CAN bus of the basic module. The available expansion modules are listed in the section Ordering code. Further information can be found in the separate datasheet for the expansion modules.

## → Technical data

General data	
Rated operating voltage	24 V DC
Operating voltage range	20 ... 32 V DC
Power consumption	max. 3.5 W
Humidity	max. 95 % without condensation
Connection terminals	pluggable
Cross-section rigid or flexible	
without wiresleeves	0,2 ... 2.5 mm <sup>2</sup>
with wiresleeves	0,25 ... 2,5 mm <sup>2</sup>
Housing / protection class	plastic / IP 40
Basic modules with dedicated line	
Operating and ambient temperature	0 ... +60°C
Storage temperature	0 ... +70°C
Transmission delay	
Basic variant	typically 200 ms
Extended variant	typically 500 ms
Galvanic isolation between dedicated line and supply voltage	
Input voltage of the dedicated line minimum transmission level (dep. on DIP-switch setting)	2 kV <sub>eff</sub> -8 dBV represents approx. 1,1 V <sub>pp</sub>
Sensitivity of the receiver	200 mV <sub>pp</sub> - 630 mV <sub>pp</sub> 30 mV <sub>pp</sub> @ 600 Ω

## Basic modules with optical fibre

Operating and ambient temperature	-20 ... +60°C
Transmission delay	< 100 ms

## Relay outputs

Contact loading of the relay outputs\*\*

minimum	1.2 V / 1 mA
maximum	250 V AC / 400 mA
	250 V AC / 2 A (pure ohmic load)
	30 V DC / 2 A
	110 V DC / 0.2 A
	220 V DC / 0.1 A
Total current 230 V AC (pure ohmic load)	maximum 8 A
Maximum count rate	12 Hz*
Pulse width / pause	40 ms*
Electrical isolation between output and supply voltage	4 kV <sub>eff</sub>

The information given for alternating voltages are referring to a sinusoidal alternating voltage with a frequency of 50/60 Hz and all information on an ambient temperature of 25°C, otherwise noted.

\* Other figures on request

\*\* We would be happy to supply you with more precise specifications on request.

Subject to changes without prior notice!

## → Order identification

### Basic modules for fibre optic transmission

Single mode 9/125 µm fibre optic @1310 nm

Plugs ST® (BFOC/2,5 acc. to standard IEC 60874-10)

Article No.:	Type:	Variant:
97BLAGCN1BX1	MF-L1S00-G8DAR-DIA-1-BX-1	8 relay outputs

Multi-mode 50/125 µm fibre optic and 62.5/125 µm fibre optic @1300 nm

Plugs ST® (BFOC/2,5 acc. to standard IEC 60874-10)

Article No.:	Type:	Variant:
97BLBGCN1BX1	MF-L1M10-G8DAR-DIA-1-BX-1	8 relay outputs

Multi-mode 50/125 µm fibre optic and 62.5/125 µm fibre optic @820 nm

Plugs ST® (BFOC/2,5 acc. to standard IEC 60874-10)

Article No.:	Type:	Variant:
97BLCGCN1BX1	MF-L1M20-G8DAR-DIA-1-BX-1	8 relay outputs

### Basic module for dedicated line transmission

Article No.:	Type:	Variant:
97BABGCNSBX1	MF-ASM0D-G8DAR-DIA-S-BX-1	Basic / 8 relay outputs
97BABGCNSBX2	MF-ASM0D-G8DAR-DIA-S-BX-2	Extended / 8 relay outputs

### Expansion module

Article No.:	Type:	Variant:
97AXXGAX0BB0	EM-G8DEX-0-BB-0	8 digital inputs 24 V
97AXXGCX0BX0	EM-G8DAR-0-BX-1	8 digital relay outputs
97AXXGBX0BB0	EM-G8DAL-0-BB-1	8 digital transistor outputs
97AXXGEX0BX0	EM-G4AE0-0-BX-0	4 analog inputs (0...20mA or 0...10 V)
97AXXGIX0BX0	EM-G4AA0-0-BX-0	4 analog outputs (0...20mA or 0...10 V)

 Expansions modules with digital inputs are also available for the signal voltages of 12 V, 60 V, 110 V and 220 V. Detailed information of the expansion modules can be found in the separate datasheet MFW-Expansion modules.

Additional accessories and furthermore information can be found in the respective product groups in the catalog.

→ You will find a suitable power supply within our accessories portfolio.



## Power supplies

### WSN 0,9/24 Wide range switching power supply

- Compact 22,5 mm thin power supply
- Input voltage range nominal 100 .... 240 V AC
- Output voltage 24 V DC
- Rated output current 0,9 A

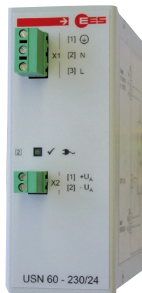

### WSN 60 Wide range switching power supply

- Input voltage range nominal 100 .... 240 V AC
- Output voltage 24 V DC
- Rated output current 0,9 A

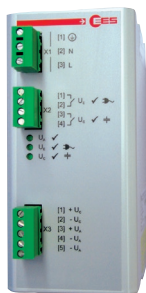

## Uninterruptible power supplies

### CBS - Capacitor Backed 24 V power Supply

- Broad input voltage 115 ... 230V AC
- Nominal output current 2 A
- High life time: 30 years@30° degrees Celsius
- Maintenance-free by long-lasting ultra capacitors
- Energy storage for 500 or 1000 J

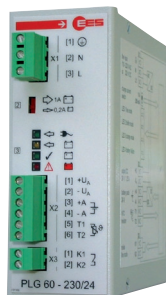

### PLG 60 - Accumulator buffered 24 V power supply

- Input voltage range                      90 ... 264 V AC  
    127 ... 370 V DC
- Output nominal current 1,25 A
- Usable for lead and gel accumulators with capacities of 1.2 Ah up to 38 Ah
- High efficiency by microcontroller supported loading and discharging of the accumulator
- Higher accumulator life time by an optional temperature sensor

→ Contact