

POSIROT® PRAS20 Magnetic Angle Sensor with Analog Output

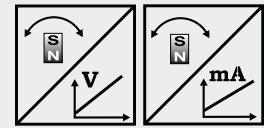

Magnetic angle sensor 0 - 360°

- Measurement range 0 - 360°
- Protection class IP60
- Analog output
- Non-contact with external position magnet
- Wear free
- Compact, low profile housing
- Other outputs available on request
- Redundant second channel as option



Specifications	Outputs	U2B U6 I1B	Tension 0.5 ... 10 V Tension 0.5 ... 4.5 V ratiometr. Current 4 ... 20 mA (3 wire)
	Measurement range		0 ... 15° to 0 ... 360° in 15° increments
	Resolution		0.03 % (60 ... 360); 0.1 % (15 ... 45°)
	Repeatability		±0.03 % (60 ... 360°); ±0.1 % (15 ... 45°)
	Linearity		±0.5 % f.s. (typ.)
	Rated distance sensor / magnet		Depending on the position magnet
	Protection class		IP60
	Signal characteristics		CW, CCW
	Material		Epoxy glass fiber, thermoplastic
	Connection		Single wire ETFE 3 x 0.5 mm ²
Mounting		Screws M4	
Shock		EN60068-2-27:1993, 100 g/11 ms, 100 shocks	
Vibration		EN60068-2-6:1995, 20 g 10 Hz-2 kHz, 10 cycles	

Order Code PRAS20

Model name

Measurement range 15 ... 360° in 15° increments

15 / 30 / 45 / ... / 345 / 360

Output (see page 5)

U2B = 0.5 ... 10 V

U6 = 0.5 ... 4,5 V ratiometric

I1B = 4 ... 20 mA, 3 wire

Signal characteristics

CW = Signal increasing CW

CCW = Signal increasing CCW

Connection

A300 = Single wire ETFE 3 x 0.5 mm², length 300 mm

PRAS20

Order code position magnet (see accessories page 7/8)

PRMAG ...

Order example: PRAS20 - 360 - U2B - CW - A300

POSIROT®
PRAS20
Dimensions



Outline drawing
PRAS20

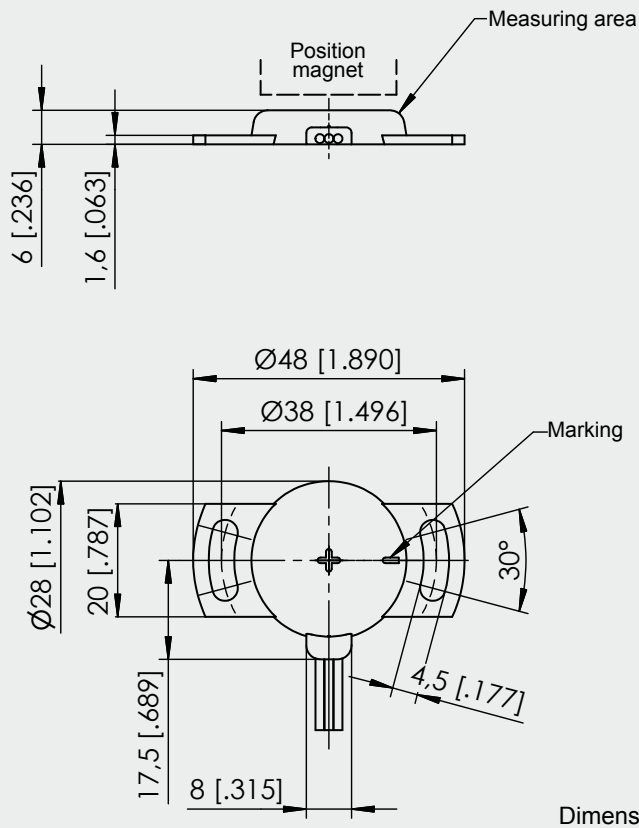

Weight without cable approx. 8 g.
 Dimensions informative only.
 For guaranteed dimensions please consult factory.

PRAS20
Magnetic shield

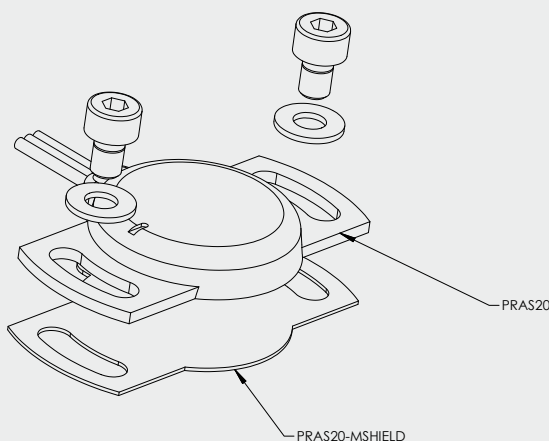

POSIROT®
PRAS21
Magnetic Angle Sensor with Analog Output



Magnetic angle sensor 0 - 360°

- Measurement range 0 - 360°
- Protection class IP60
- Analog output
- Compact, low profile housing
- Non-contact with external position magnet
- Wear free
- Other outputs available on request

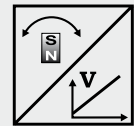

Specifications	Outputs	U6	Voltage 0.5 ... 4.5 V ratiometric
	Measurement range		0 ... 15° to 0 ... 360° in 15° increments
	Resolution		0.03 % (60 ... 360°); 0.1 % (15 ... 45°)
	Repeatability		±0.03 % (60 ... 360°); ±0.1 % (15 ... 45°)
	Linearity		±0.5 % f.s. (typ.)
	Rated distance sensor / magnet		Depending on the position magnet
	Protection class		IP60
	Signal characteristics		CW, CCW
	Material		Epoxy glass fiber, thermoplastic
	Mounting		Screws M3
	Connection		Single wire ETFE 3 x 0.5 mm2
	Shock		EN60068-2-27:1993, 100 g/11 ms, 100 shocks
Vibration		EN60068-2-6:1995, 20 g 10 Hz-2 kHz, 10 cycles	

Order Code PRAS21

Model name

Measurement range 15 ... 360° in 15° increments

15 / 30 / 45 / ... / 345 / 360

Output (see page 46)

U6 = 0.5 ... 4.5 V ratiometric

Signal characteristics

CW = Signal increasing CW

CCW = Signal increasing CCW

Connection

A300 = Single wire ETFE 3 x 0.5 mm², length 300 mm

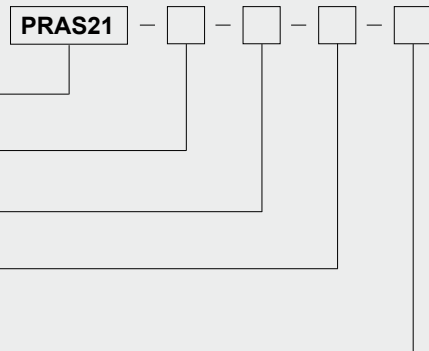

Order code position magnet (see accessories page 7/8)

PRMAG ...

Order example: PRAS21 - 360 - U6 - CW - A300

**Outline drawing
PRAS21**

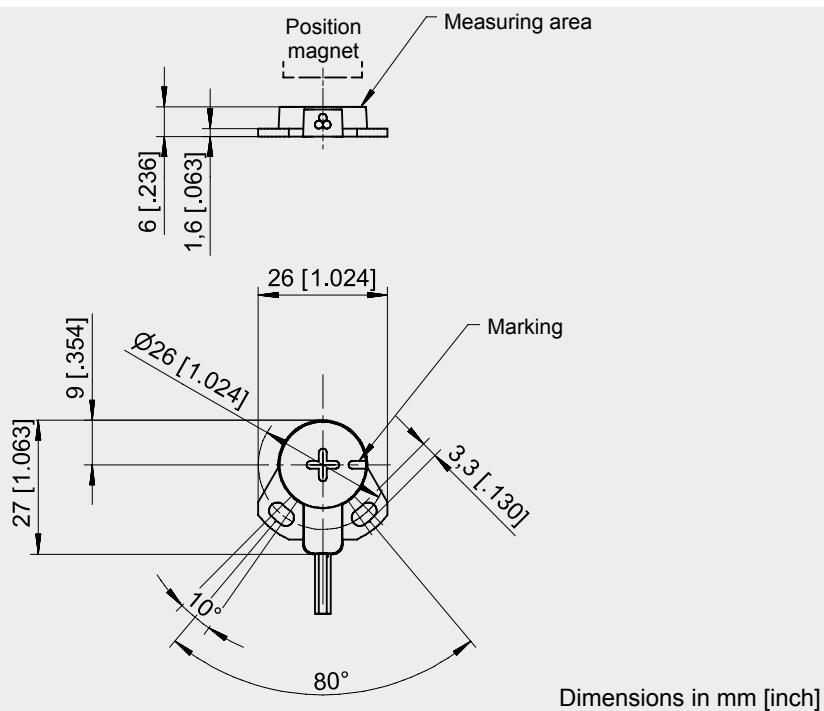

Weight without cable approx. 5 g.
Dimensions informative only.
For guaranteed dimensions please consult factory.

**PRAS21
Magnetic shield**

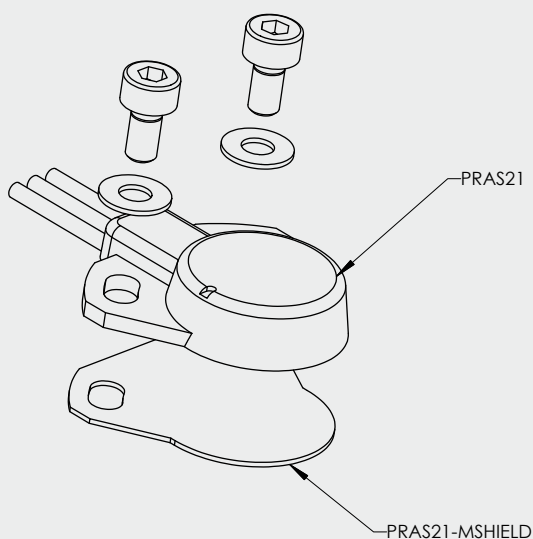

POSIROT®
PRAS
Analog outputs U2(B), U6 and I1(B)

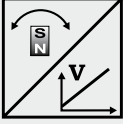
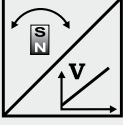
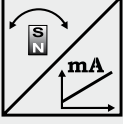

U2; U2B Voltage Output 0.5 ... 10 V 	Excitation voltage	U2: 18 ... 36 V DC; U2B: 11.5 ... 27 V DC
	Excitation current	12 mA typ., 16 mA max.
	Output voltage	0.5 ... 10 V DC
	Output current	2 mA max.
	Measuring rate	1 kHz standard
	Stability (temperature)	±50 x 10 ⁻⁶ / °C f.s. (typ.) for 90°...360° ±100 x 10 ⁻⁶ / °C f.s. (typ.) for <90°
	Operating temperature	-40 ... +85 °C (+105 °C as option)
	Protection	Reverse polarity, short circuit
EMC	EN61326-1:2006	
U6/5; U6/8,25 Voltage Output 10 ... 90% ratiometr. 	Excitation voltage	5V DC ±10 % / 8.25 V DC ±10 %
	Excitation current	8 mA typ., 12 mA max.
	Output voltage	10 ... 90 % of the excitation voltage
	Output current	2 mA max.
	Measuring rate	1 kHz standard
	Stability (temperature)	±50 x 10 ⁻⁶ / °C f.s. (typ.) for 90°...360° ±100 x 10 ⁻⁶ / °C f.s. (typ.) for <90°
	Operating temperature	-40 ... +85 °C (+125 °C as option)
	Protection	Reverse polarity, short circuit
EMC	EN61326-1:2006	
I1; I1B Current Output 4 ... 20 mA, 3 wire 	Excitation voltage	I1: 18 ... 36 V DC; I1B: 10 ... 18 V DC
	Excitation current	32 mA typ., 36 mA max.
	Load resistor	I1: 500 Ω max.; I1B: 250 Ω max.
	Output current	4 ... 20 mA
	Measuring rate	1 kHz standard
	Stability (temperature)	±50 x 10 ⁻⁶ / °C f.s. (typ.) for 90°...360° ±100 x 10 ⁻⁶ / °C f.s. (typ.) for <90°
	Operating temperature	-40 ... +85 °C
	Protection	Reverse polarity, short circuit
EMC	EN61326-1:2006	

Other outputs available on request.

Output signals

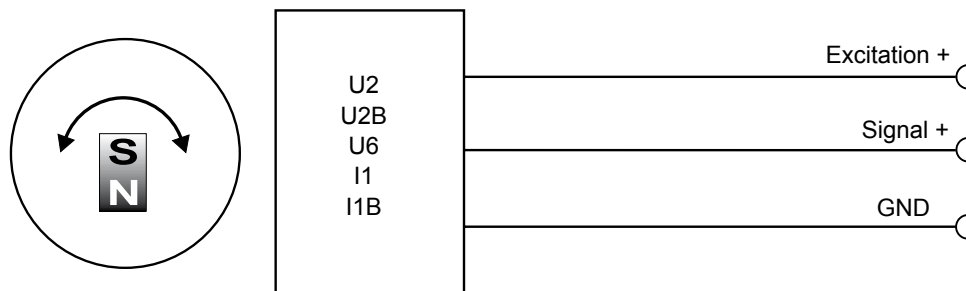

Signal Wiring	Output signals	Connector pin	Cable color
	Excitation +	1	brown
	Signal	2	white
	GND	3	blue
	Do not connect!	4	black
	Do not connect!	5	-

Connection

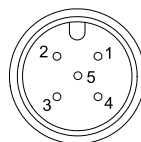

M12A5 / M12R5

View to sensor
connector

POSIROT[®]
PRAS/PRDS
Characteristics for magnetic angle sensors



Output signal
 (CW increasing)

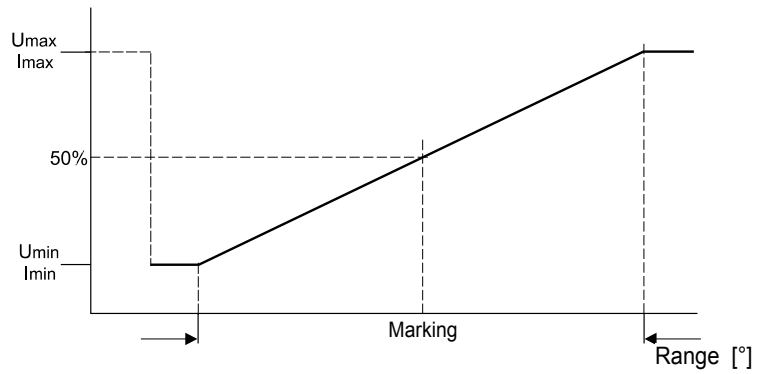

Output signal
 (CCW increasing)

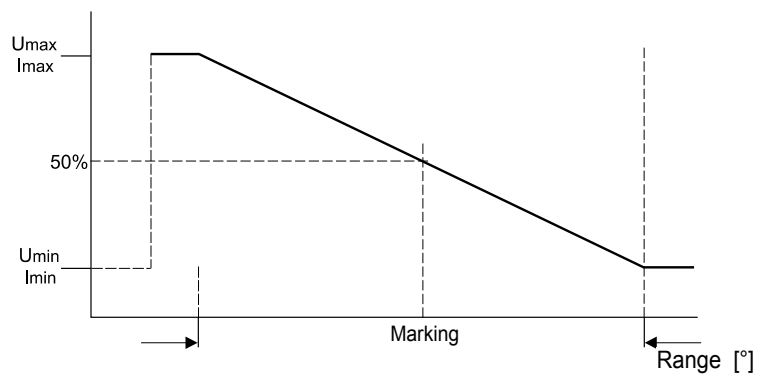

Example angular
range 90°

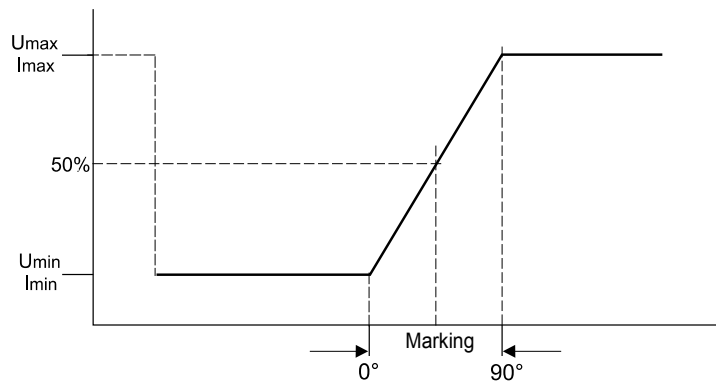

Example angular
range 360°

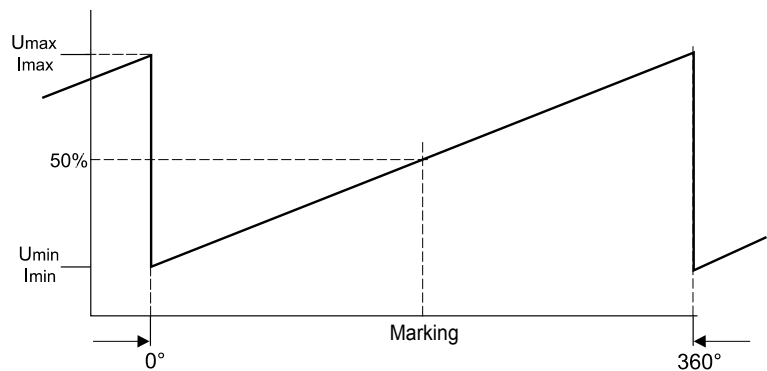

PRMAG20

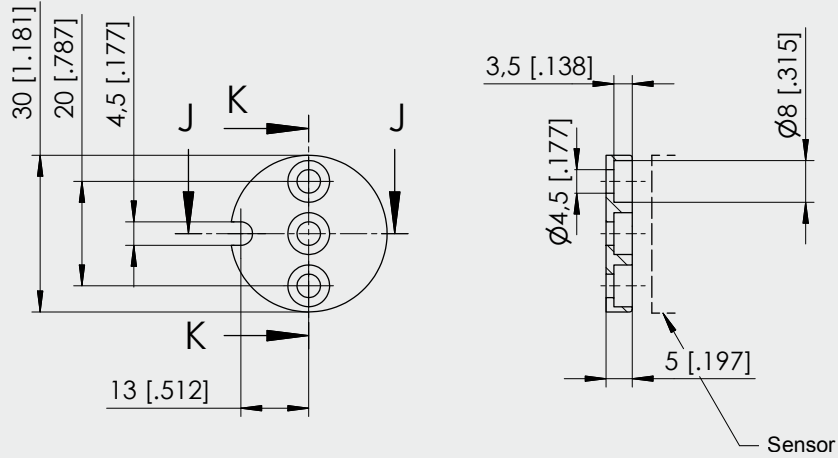

Weight 11 g approx.,
moment of inertia 1.2 kgmm²

A misalignment of the position magnet
has an effect on the linearity

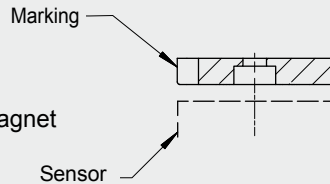

PRMAG21

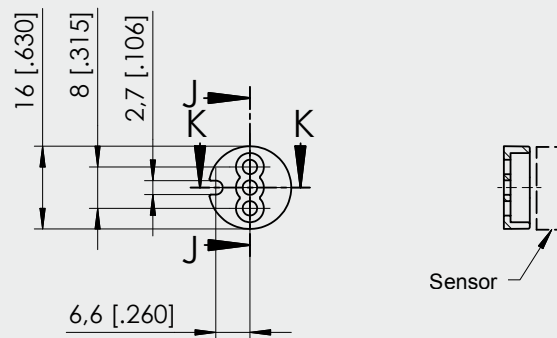

Weight 3 g approx.,
moment of inertia 0.1 kgmm²

A misalignment of the position magnet
has an effect on the linearity

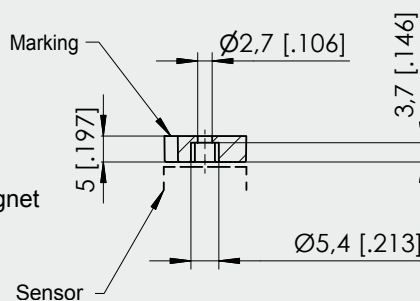

Dimensions in mm [inch]

Dimensions informative only
For guaranteed dimensions please consult factory

POSIROT®
Accessories
Position magnets



PRMAG22

Weight 17 g approx.,
 moment of inertia 3 kgmm²

A misalignment of the position magnet
 has an effect on the linearity

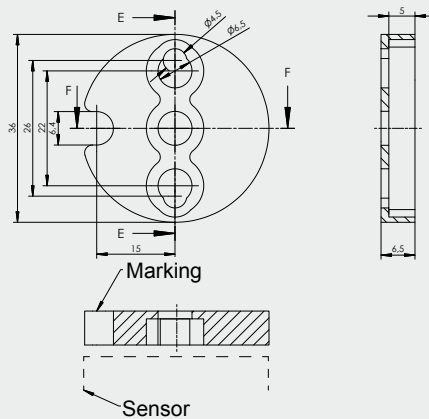

PRMAG5Z

Weight 100 g approx.,
 moment of inertia 55 kgmm²

A misalignment of the position magnet
 has an effect on the linearity

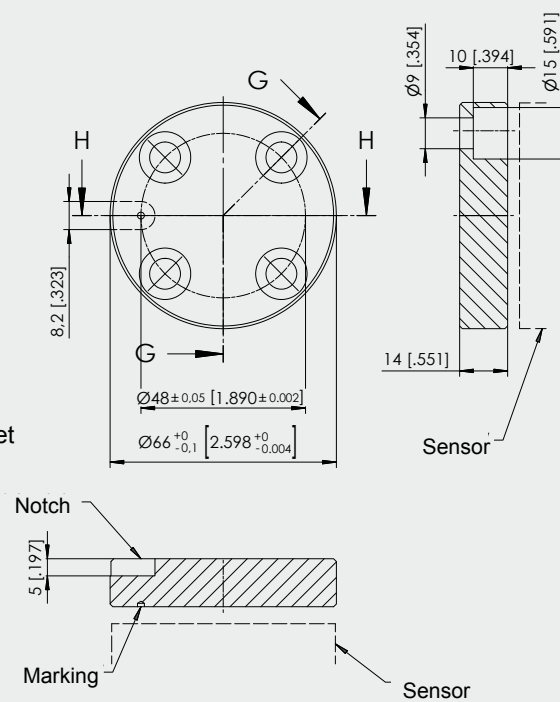

Dimensions in mm [inch]

Dimensions informative only
 For guaranteed dimensions please consult factory