

Liquid Ring Vacuum Pumps

VHC series

Two-stage pumps in base plate version



Applications



Food, Beverage and Cosmetics industries

- » Filling bottles with beer, mixed beverages, mineral water and similar
- » Vacuum cutters
- » General processes such as degasification, extraction, suction and vacuum cooking
- » Curing systems
- » Production of sugar and chocolate
- » Production of emulsions and suspensions



Chemical & Pharmaceutical industry

- » Distillation and separation of liquids
- » Recovery of condensates, e. g. solvents
- » Drying of bulk solids, e. g. washing powder, fertiliser, salts, plastic granulates etc.
- » Extraction of liquids, e. g. palm oil



Medical engineering

- » Sterilisation with laboratory and clinical sterilisers



Plastics production and plastics processing

- » Extruder degasification
- » Manufacturing of EPS moulded parts
- » Drying of plastic granulate
- » Decontamination in PET recycling processes

Liquid ring vacuum pumps from Speck

Tailored solutions in modular system

- » Two-stage vacuum pumps
- » Can be used universally for compressing practically all gases and vapours
- » Constant suction performance for different applications
- » Mechanical seal, magnetic coupling or packing gland
- » Application-specific selection of materials like grey cast iron, stainless steel or special alloys
- » ATEX certified

Media	dry and humidified gases
Operating liquid	max. 80 °C
Absorbed gas	dry max. 200 °C saturated max. 100 °C
Minimum inlet pressure	33 mbar abs., 5 mbar abs. with gas ejectors
Flow rate	110 - 1600 m³/h

VHC Series

Two-stage pumps in base plate version



Innovative liquid ring vacuum pumps for universal use

Liquid ring vacuum pumps

are used in many sectors in discontinuous and continuous operation in the three basic processes of extraction, leakage extraction and degasification, for example: extracting dry gases, saturated gases and vapours, extracting contaminated gases

Application-specific benefits

- » Delivering liquid shares at a constant vacuum
- » Delivering explosive gases, e.g. hydrogenous, inflammable or toxic media
- » Oil-free compression, i.e. no oil in the medium nor in the exhaust air
- » Use of the condensed process medium as operating liquid

VHC series - benefits at a glance

Full interchangeability

The VHC series is replacing the previous VH series. The connecting dimensions of the suction and pressure ports, the operating liquid connections, the pump shaft and the pump feet are identical.

Robust bearings

Small spacing of the bearings, lifetime-lubricated deep groove ball bearings

Inter casings in rust-free material

Made from surface-hardened stainless steel for a longer service life

Optimal flushing of the mechanical seal

Pump shaft in stainless steel

For universal use

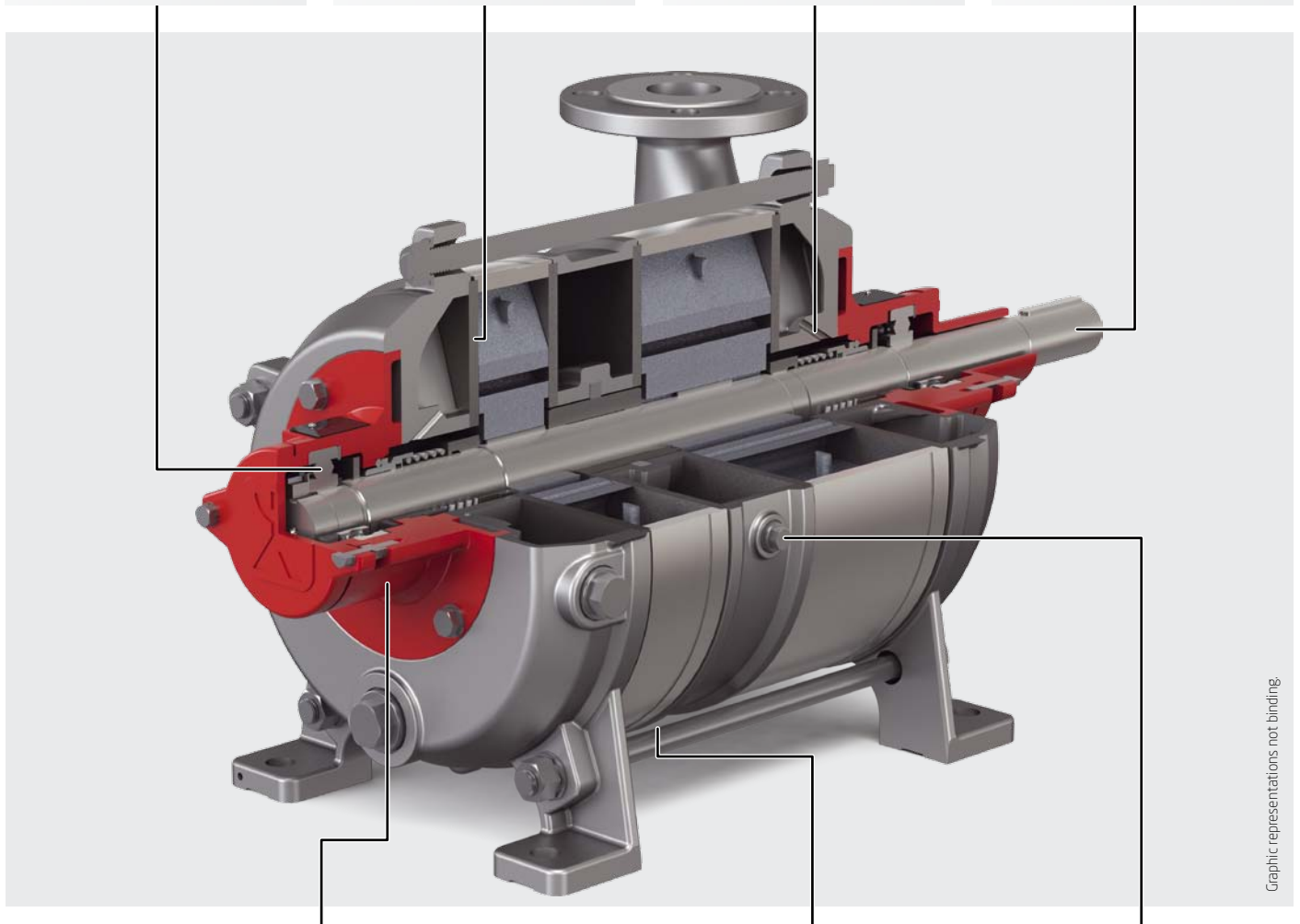

Graphic representations not binding.

Compact and closed bearing bracket

Simple and fault-free disassembly and assembly without special tools, problem-free setting of the impeller sets

Central drainage

Quick and total drainage of the pump

Pre-set cavitation protection

Safe commissioning and cavitation-free operation

Tailored, long-lasting and service-friendly solution

The VHC series from Speck is the natural development of the established VH series. It was designed taking into account the requirements of our customers. The result is a heavily standardised series, that sets new standards in safety, durability and reliability for your system.

Tailored solution

The VHC series consists of a comprehensive modular system. With easily configurable options and individual special solutions, we fulfil the highest customer requirements and guarantee safe operation.

Mechanical seals

At Speck, you receive a wide range of single and double-action mechanical seals from brand manufacturers with slide rings in A carbon, B carbon, SiC, Cr steel, stainless steel and with O-rings in FKM, EPDM, FFKM, NBR etc.

Magnetic couplings

For applications with toxic, corrosive and combustible media, all sizes are also available in hermetically sealed versions with magnetic coupling. Thanks to the magnetic coupling free from eddy current losses used in the VHC, the power consumption is significantly reduced compared with a conventional magnetic coupling.

Packing glands

The low-cost solution for simple applications with uncritical media.

Application-specific material selection

Speck also offers a wide range of medium-specific pump designs suitable for acids, lyes, hydrocarbons, glycol, glycerine, for example. For the stage sealing, we have a selection of flat gaskets made from various materials, cord packing made from Teflon® or different liquid seals from Epple® and Chesterton® at our disposal.

ATEX / TA Luft (Technical Instruction on Air Quality Control)

The VHC series is type-tested for ATEX in accordance with category 1G (+H2).

The version with magnetic coupling fulfils the strictest requirements of TA Luft (Technical Instruction on Air Quality Control).

Reliable and long-lasting

The solid and compact design, combined with reliable components, guarantees high operational reliability and a significantly extended service life.

The robust and life-time lubricated rolling bearings, improved flushing of the mechanical seals and the surface-hardened inter casings made from stainless material also help to prolong the service life.

The cavitation protection installed in the pump intermediate stage by Speck enables easy commissioning and safe operation without readjustment and performance losses.

The new design of the VHC series also guarantees safe external cleaning and central complete drainage on the product side. The bearing brackets come closed, splash-proof and optionally also rust-free.

Service-friendly

In operation

The VHC series is characterised by low maintenance costs and high system availability. Maintenance-free rolling bearings, hardened stainless steel inter casings without valves and the improved flushing of the mechanical seals reduce the maintenance requirements and the operating costs considerably.

During assembly

Assembly is much easier and kept as simple as possible thanks to the significantly reduced number of components. The proven and simple segment design has been perfected and enables simple and fault-free disassembly and assembly in just a short time.

For spare parts storage

In the consistently designed modular system with 11 sizes, many components are completely interchangeable within a size family. Wear parts like mechanical seals and bearings are identical across several sizes and help to reduce the stored quantities.



VHC in TA Luft design → pages 12 and 13

Characteristic curves VHC0110/0140/0180

50 Hz – 1450 min⁻¹

60 Hz – 1750 min⁻¹

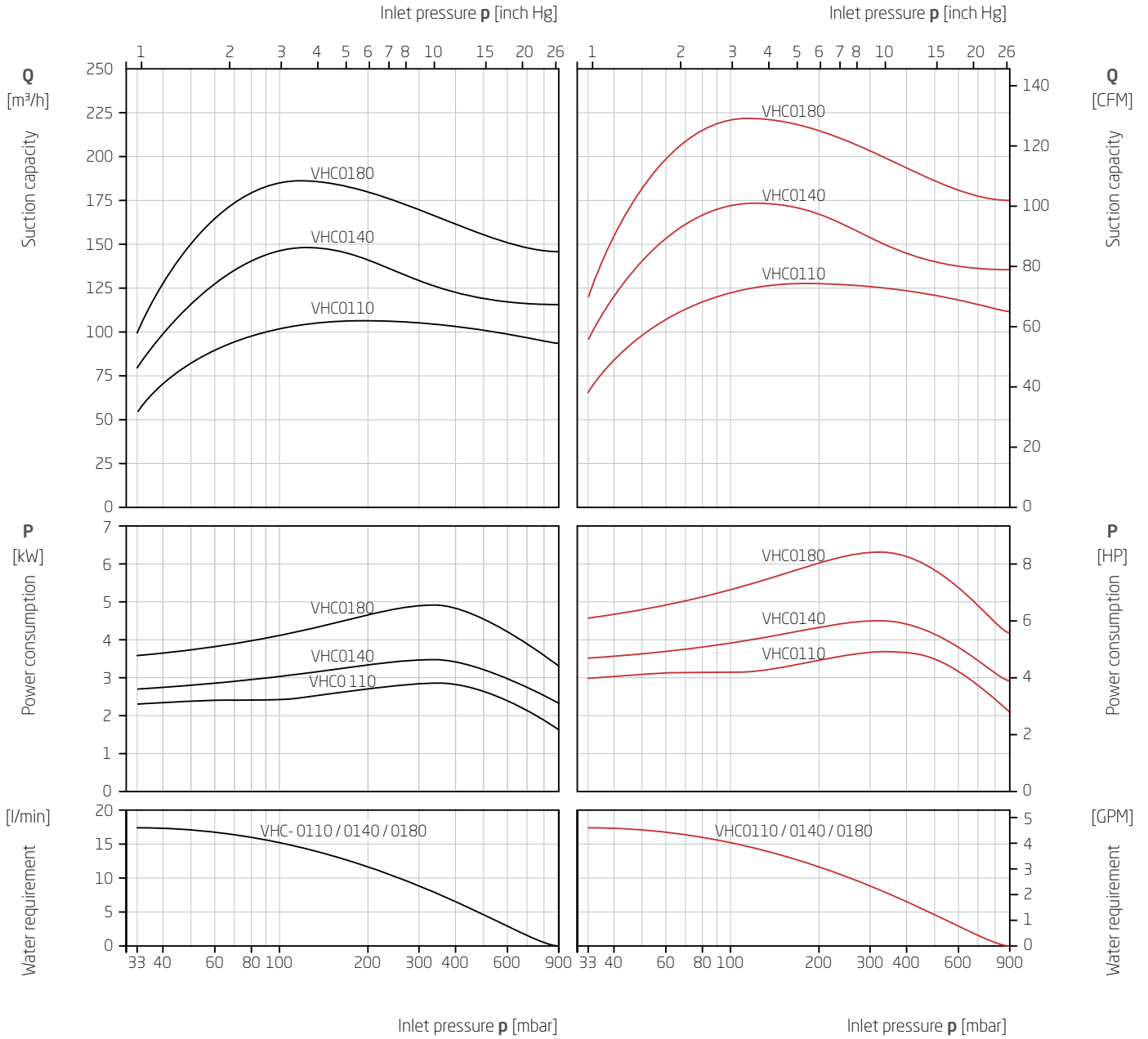

Suction capacity and power consumption depending on inlet pressure

The characteristics are applicable for compression of 20 °C (68 °F) dry air from inlet pressure to atmospheric pressure (1013 mbar / 30 inch Hg a) for nominal speed and drive with three phase motors. Ring liquid is water at 15 °C (59 °F). The tolerance of the suction capacity is -10 % and of the power consumption +10 %.

With different operating conditions characteristic curves change (e.g. differing gas operating liquid conditions, conveying of additional liquids and/or pumping of gas-steam mixtures).

Characteristic curves VHC0300/0350/0400

50 Hz – 1450 min⁻¹

60 Hz – 1750 min⁻¹

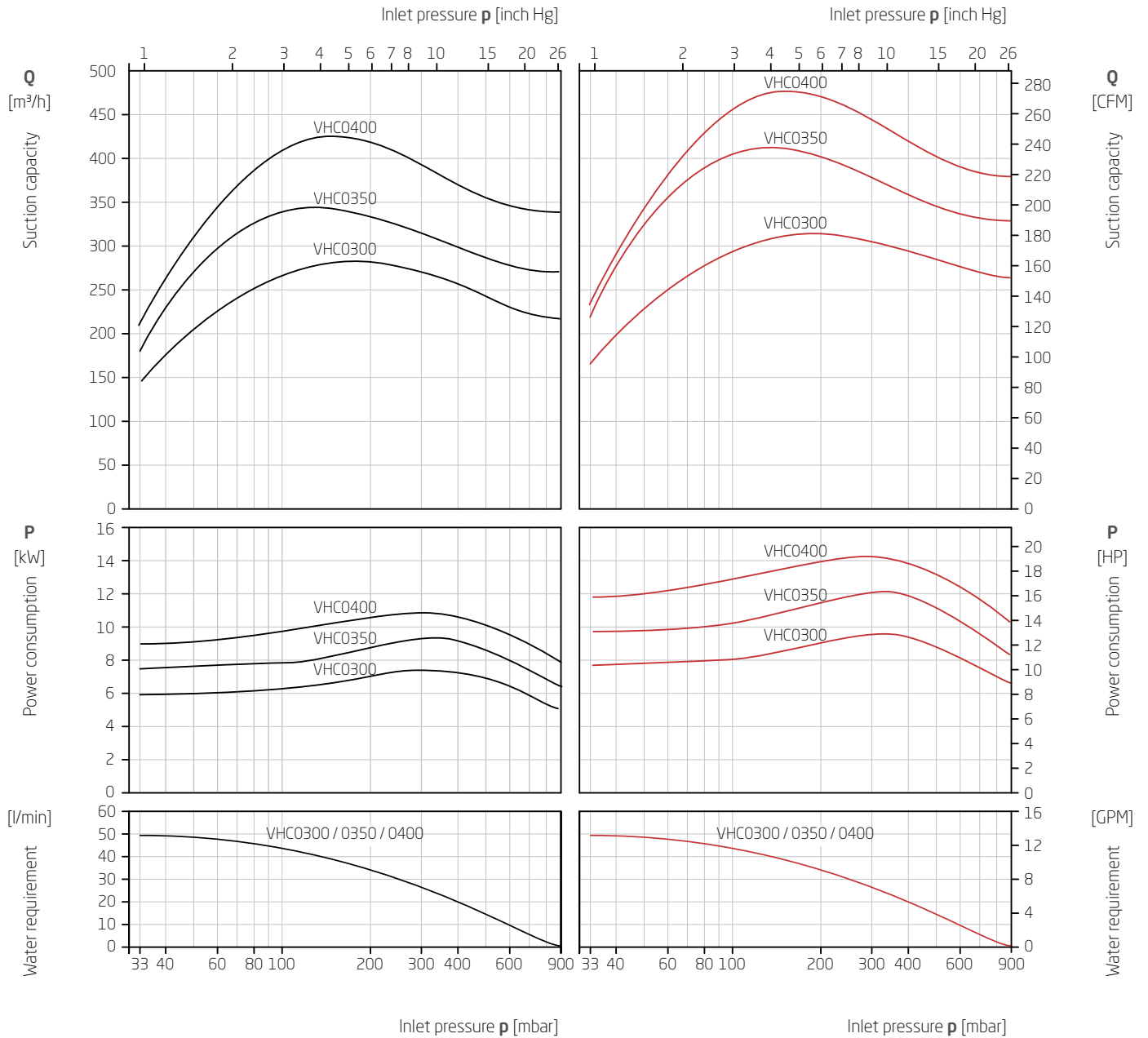

Suction capacity and power consumption depending on inlet pressure

The characteristics are applicable for compression of 20 °C (68 °F) dry air from inlet pressure to atmospheric pressure (1013 mbar / 30 inch Hg a) for nominal speed and drive with three phase motors. Ring liquid is water at 15 °C (59 °F). The tolerance of the suction capacity is -10 % and of the power consumption +10 %.

With different operating conditions characteristic curves change (e.g. differing gas operating liquid conditions, conveying of additional liquids and/or pumping of gas-steam mixtures).

Characteristic curves VHC0500/0600

50 Hz - 1450 min⁻¹

60 Hz - 1750 min⁻¹

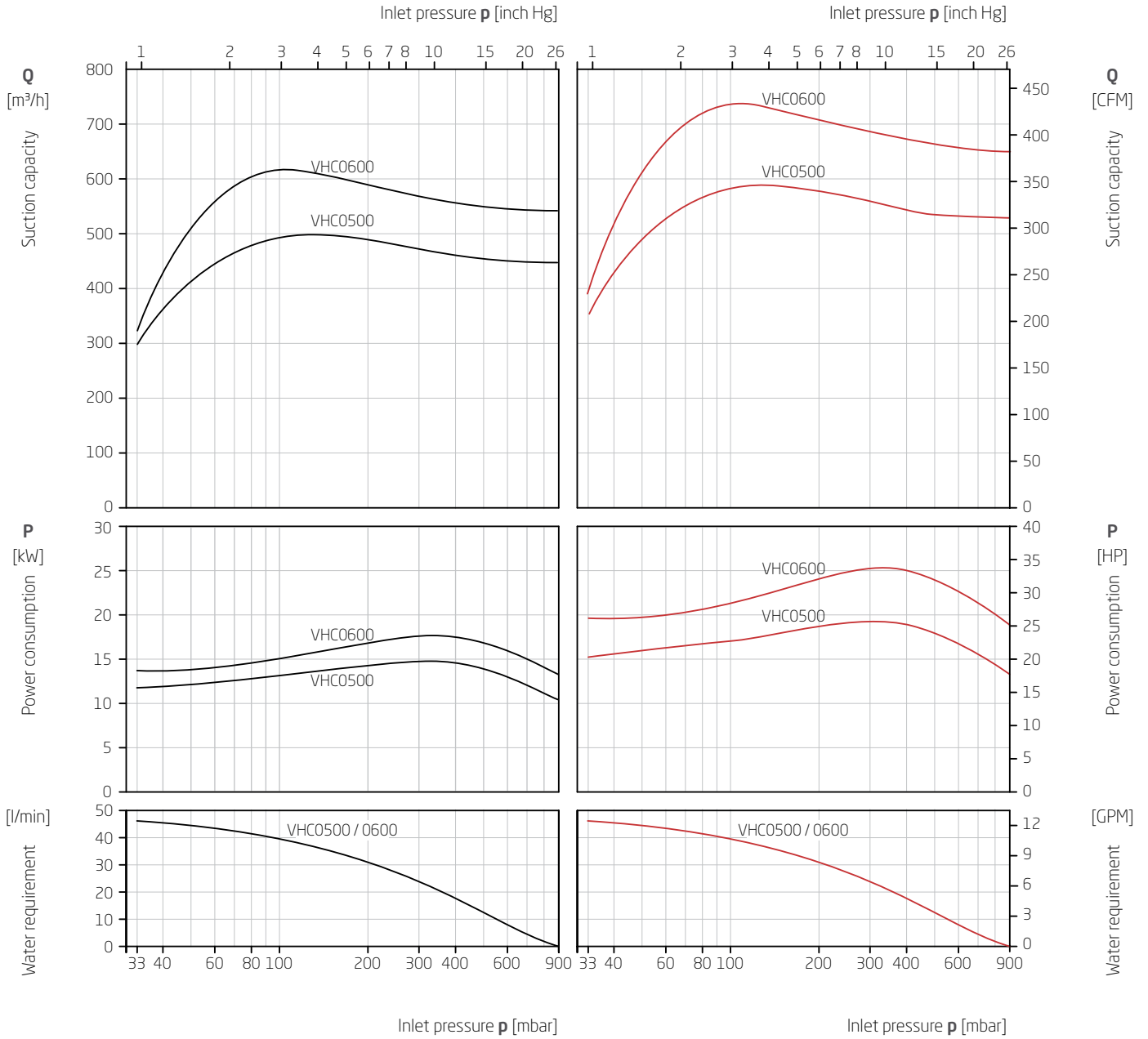

Suction capacity and power consumption depending on inlet pressure

The characteristics are applicable for compression of 20 °C (68 °F) dry air from inlet pressure to atmospheric pressure (1013 mbar / 30 inch Hg a) for nominal speed and drive with three phase motors. Ring liquid is water at 15 °C (59 °F). The tolerance of the suction capacity is -10 % and of the power consumption +10 %.

With different operating conditions characteristic curves change (e.g. differing gas operating liquid conditions, conveying of additional liquids and/or pumping of gas-steam mixtures).

Characteristic curves VHC0800/1200/1600

50 Hz – 975 min⁻¹

60 Hz – 1175 min⁻¹

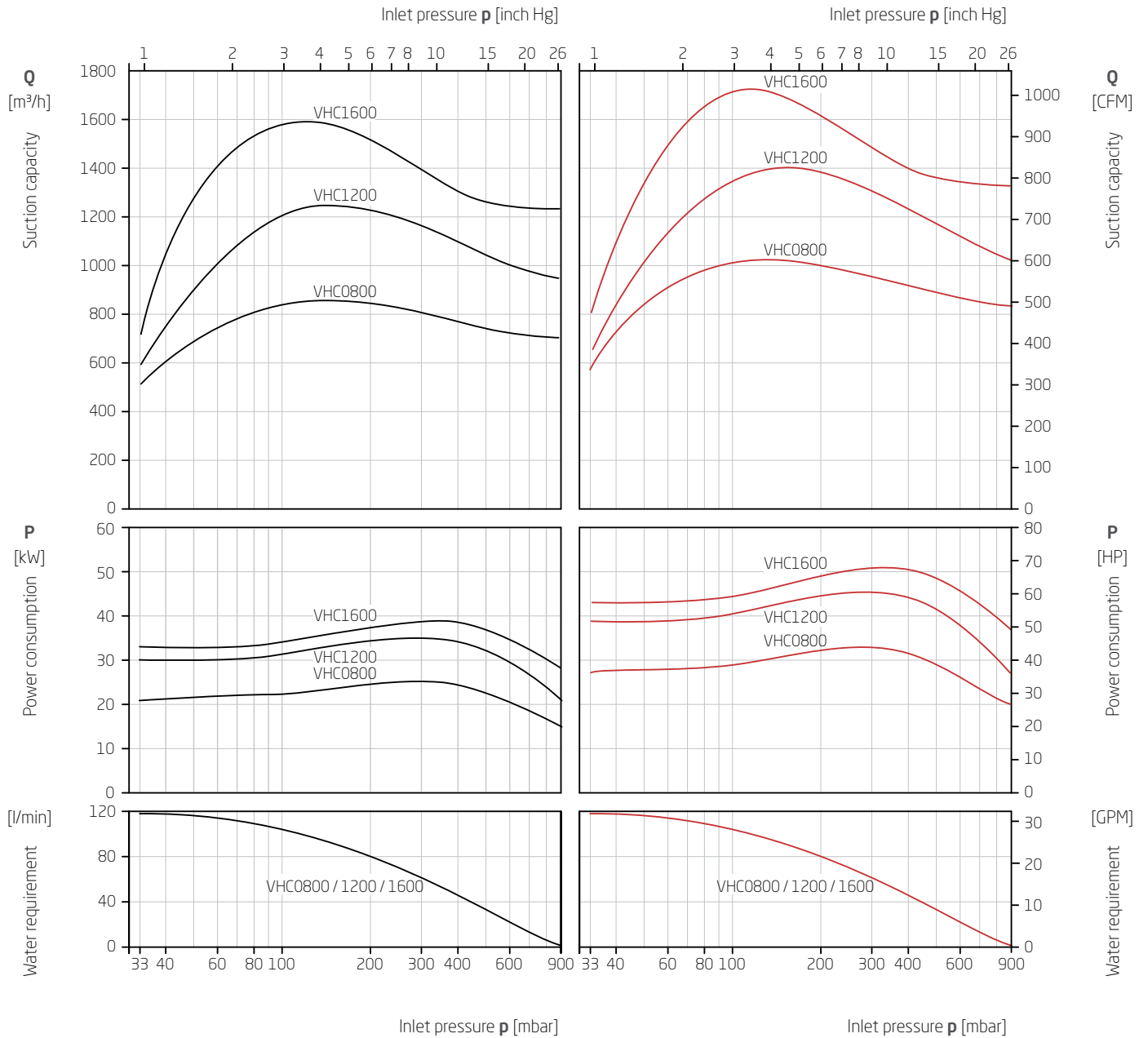

Suction capacity and power consumption depending on inlet pressure

The characteristics are applicable for compression of 20 °C (68 °F) dry air from inlet pressure to atmospheric pressure (1013 mbar / 30 inch Hg a) for nominal speed and drive with three phase motors. Ring liquid is water at 15 °C (59 °F). The tolerance of the suction capacity is -10 % and of the power consumption +10 %.

With different operating conditions characteristic curves change (e.g. differing gas operating liquid conditions, conveying of additional liquids and/or pumping of gas-steam mixtures).

Technical data

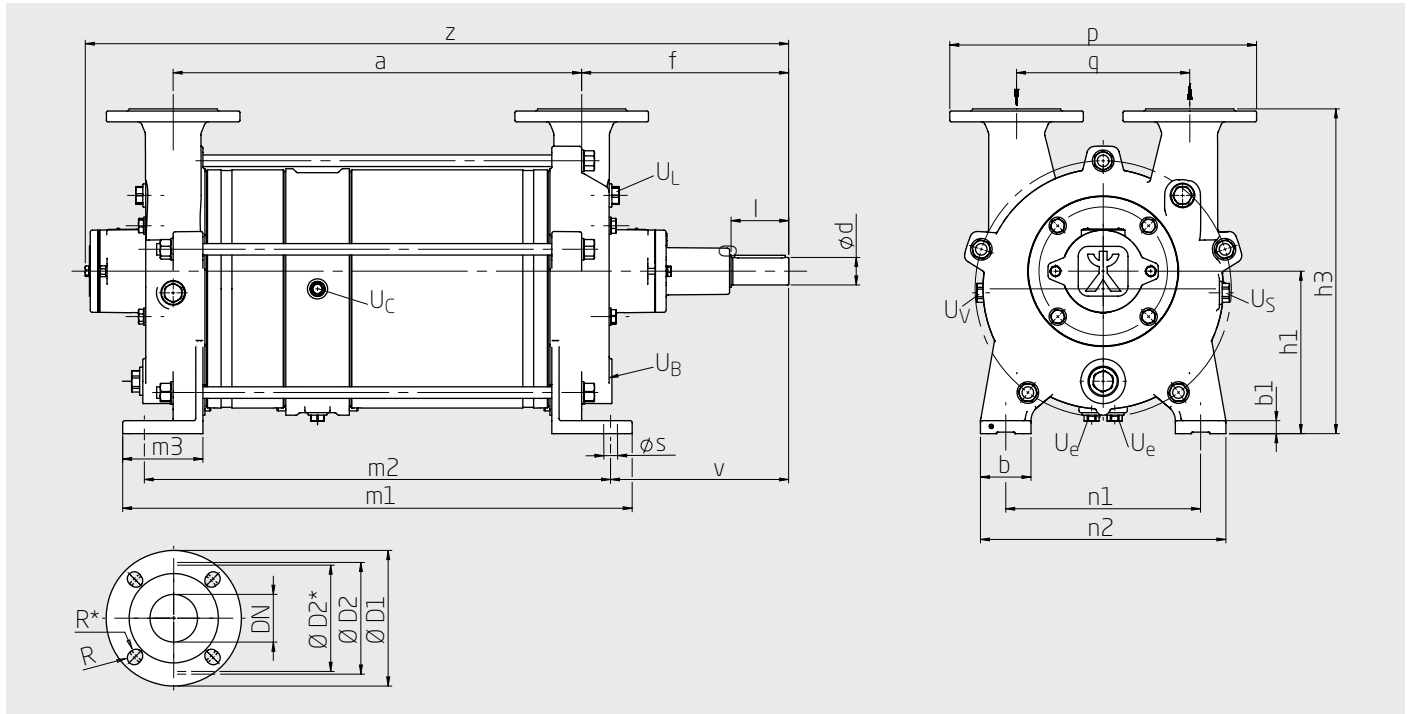

Dimensions

Type	a	b	b1	Ød	DN	f	h1	h3	l	m1	m2	m3	n1	n2	p	q	Øs	v	z
VHC0110	239	50	15	28	40	184	160	320	50	335	298	74	200	250	330	180	15	155	531
VHC0140	269	50	15	28	40	184	160	320	50	365	328	74	200	250	330	180	15	155	561
VHC0180	339	50	15	28	40	184	160	320	50	435	398	74	200	250	330	180	15	155	631
VHC0300	335	60	17	38	50	282	212	402	80	435	385	80	240	300	395	230	19	257	743
VHC0350	375	60	17	38	50	282	212	402	80	475	425	80	240	300	395	230	19	257	784
VHC0400	435	60	17	38	50	282	212	402	80	535	485	80	240	300	395	230	19	257	844
VHC0500	500	70	18	38	65	287	225	450	80	640	580	111	270	340	425	240	19	247	902
VHC0600	566	70	18	38	65	287	225	450	80	706	646	111	270	340	425	240	19	247	968
VHC0800	450	98	21	60	100	422	320	595	140	694	620	123	380	480	590	370	19	382	1131
VHC1200	690	98	21	60	100	422	320	595	140	844	770	123	380	480	590	370	19	382	1281
VHC1600	790	98	21	60	100	422	320	595	140	944	870	123	380	480	590	370	19	382	1381

Connection dimensions

Type	U _b	U _c	U _e	U _L	U _S	U _V
VHC0110	G ½	G ⅝	G ⅝	G ½	G ¾	G ¾
VHC0140	G ½	G ⅝	G ⅝	G ½	G ¾	G ¾
VHC0180	G ½	G ⅝	G ⅝	G ½	G ¾	G ¾
VHC0300	G 1	G ¾	G ¾	G ¾	G ¾	G ¾
VHC0350	G 1	G ¾	G ¾	G ¾	G ¾	G ¾
VHC0400	G 1	G ¾	G ¾	G ¾	G ¾	G ¾
VHC0500	G 1	G ¾	G ½	G ¾	G ¾	G ¾
VHC0600	G 1	G ¾	G ½	G ¾	G ¾	G ¾
VHC0800	G 2	G ½	G ½	G 1 ½	G ¾	G ¾
VHC1200	G 2	G ½	G ½	G 1 ½	G ¾	G ¾
VHC1600	G 2	G ½	G ½	G 1 ½	G ¾	G ¾

Connection designations

Abb.	Designation
U _b	Connection for operating liquid
U _c	Protection against cavitation
U _e	Connection for drainage
U _L	Connection for ventilation valve
U _S	Connection for sensor
U _V	Connection for drain valve

Flanges

Size DN	EN 10921 PN 10			ANSI	
	D1	D2	R Ø	RØ	D2 (ANSI)
40	150	110	18	19.1	98.6
50	165	125	18	19.1	129.3
65	185	145	18	19.1	152.4
100	220	180	18	19.1	190.5

Type codes with seal and materials

	VHC	0600	M	-53	-15	-000
	VHC	0400			-65	-000
Series						
Size						
Design with magnetic coupling						
Mechanical seal (table 1)						
Materials (table 2)						
Counting number						

Table 1: Mechanical seal

Code	41	50	53	55
	Carbon, Cr steel, NBR	Carbon, stainless steel, FFKM	Carbon, stainless steel, FFKM	Carbon, stainless steel, FFKM double PTFE-coated

Table 2: Materials

Code	15	35	65
Suction casing, discharge casing, intermediate casing and casing for shaft sealing	EN-GJL-250 Grey cast iron	EN-GJL-250 Grey cast iron	1.4581 CrNiMo cast steel
Inter casing	1.4301 CrNi steel	1.4301 CrNi steel	1.4571 CrNiMo steel
Stage casing	Steel	Steel	1.4571 CrNiMo steel
Impellers	CuSn / RG / 1.4027 / 1.4308* Bronze / red bronze / CrNi / CrNi cast steel*	1.4581 / 1.4027 / 1.4308* CrNiMo / CrNi / CrNi cast steel*	1.4581 CrNiMo cast steel
Shaft	1.4122 CrMo steel	1.4122 CrMo steel	1.4571 CrNiMo steel

*Precise material specifications on request

Performance data

Types	50 Hz				60 Hz			
	power consumption		max. suction capacity		power consumption		max. suction capacity	
	[kW]	[HP]	[m³/h]	[CFM]	[kW]	[HP]	[m³/h]	[CFM]
VHC0110	2.9	3.9	107	63	3.7	5.0	128	75
VHC0140	3.5	4.7	145	85	4.5	6.0	174	102
VHC0180	4.9	6.6	186	109	6.3	8.4	223	131
VHC0300	7.3	9.8	283	167	9.5	12.7	314	185
VHC0350	9.3	12.5	342	201	12.1	16.2	411	242
VHC0400	10.9	14.6	425	250	14.2	19.0	475	280
VHC0500	14.5	19.4	501	295	18.9	25.3	590	347
VHC0600	17.6	23.6	616	363	25.1	33.7	739	435
VHC0800	25.8	34.6	862	507	32.7	43.9	1032	607
VHC1200	34.9	46.8	1252	737	45.4	60.9	1407	828
VHC1600	39.2	52.6	1589	935	50.9	68.3	1717	1011

Sizes of the previous VH* series still available

Size	50 Hz				60 Hz			
	power consumption		max. suction capacity		power consumption		max. suction capacity	
	[kW]	[HP]	[m³/h]	[CFM]	[kW]	[HP]	[m³/h]	[CFM]
VH0020	0.8	1.1	21	12	1.1	1.5	25	15
VH0040	1.3	1.8	46	27	1.7	2.3	52	31
VH0060	2.0	2.7	56	33	2.6	3.5	68	40

* → Brochure "Vacuum pumps in base plate design - series VZ, VH, VU"

ChemTAL – The VHC version according to TA Luft (Technical Instruction on Air Quality Control)

ChemTAL fulfils all legally specified requirements for air pollution control and offers a wide range of benefits.

Graphic representations not binding.

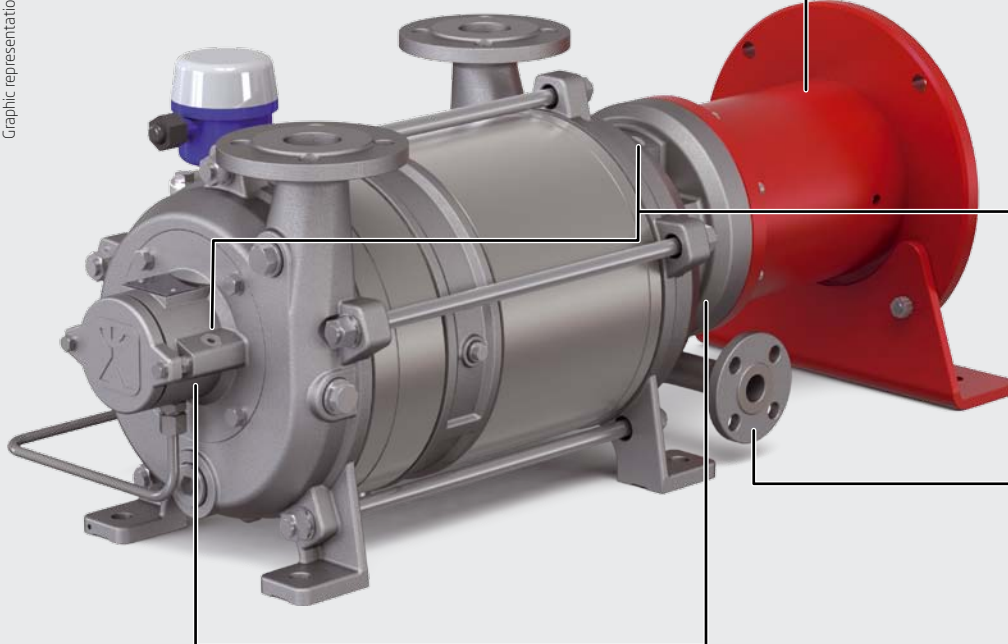

Bracket with dry-running magnetic coupling without eddy-current losses

Monitoring of the bearings and magnetic coupling - connection for vibration sensor (optional)

Operating liquid connection in flange version

Closed bearing bracket

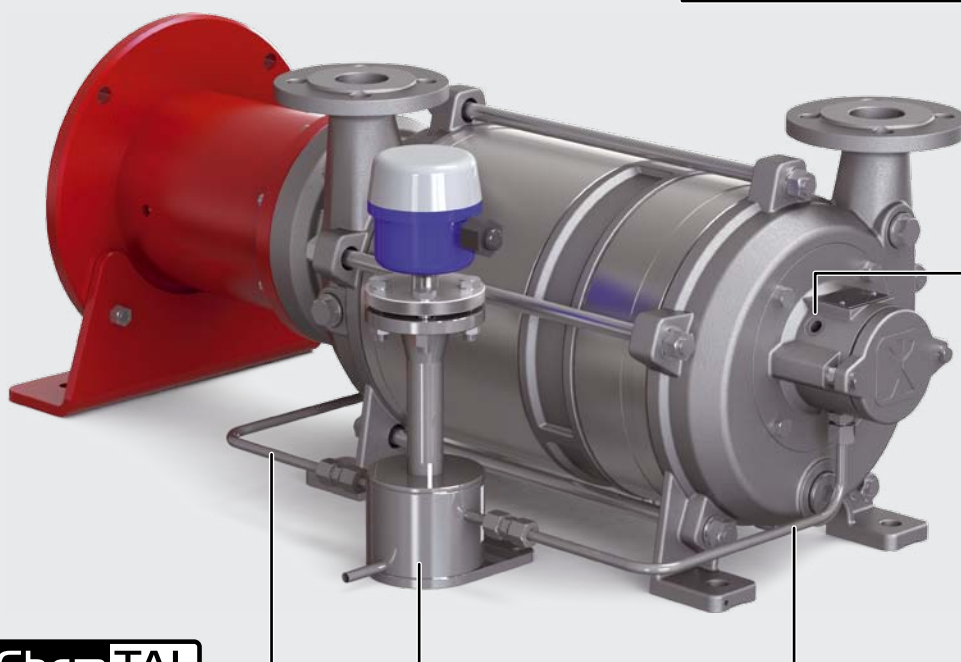

Pressure overlay connection in the mechanical seal casing

Monitoring of the two mechanical seals with a liquid sensor

ChemTAL

Safe, low lifecycle costs and durable

ChemTAL is the safe and efficient solution when using toxic, corrosive and combustible media.

The design with proven mechanical seals in combination with external rolling bearings and a dry-running magnetic coupling guarantees leak-tightness and safety. The components in contact with the media are made from stainless steel or rust-free special alloys. Various material combinations for the mechanical seals are also coordinated depending on the media to be pumped.

High operational safety

ChemTAL is safe, as the entire pump is hermetically sealed and the requirements of the legally specified TA Luft (Technical Instruction on Air Quality Control) are met.

Several monitoring systems guarantee high availability via early detection of possible wear and identification of unsuitable operating modes. Optional vibration sensors monitor the condition of the ball bearings and the magnetic coupling. The two mechanical seals are monitored by a liquid sensor. An additional nitrogen connection on the bearing brackets enables inertisation of the sealing system.

During the start-up process, ChemTAL is resistant to dry running due to the external bearings. Operating liquids with different viscosities can be used based on the process. If damage occurs on the separating can, the ChemTAL can still be used without problems for a specific time. This means that the pump maintenance can be planned in a targeted way.

All series are type-tested for ATEX to category 1G (+H2)

Low life-cycle costs

ChemTAL requires no seal supply systems, meaning it is extremely service-friendly and is characterised by low maintenance costs.

The magnetic coupling free from eddy current losses used in the VHC results in a tangible energy saving compared with conventional magnetic couplings..

Long-lasting

ChemTAL has a long service life, as lasting solutions from the VHC series are used for wear parts..

Production program

Liquid ring vacuum pumps from Speck



VI Series

The water saver

Single-stage pumps in inverted design with valves flaps and internal water restraining system

50 Hz p_{\min} : 33 mbar abs. / Q_{\max} : 45 m³/h

60 Hz p_{\min} : 33 mbar abs. / Q_{\max} : 55 m³/h



V Series

The all-rounders

Single-stage pumps with valve flaps, close-coupled and bracket versions

50 Hz p_{\min} : 33 mbar abs. / Q_{\max} : 370 m³/h

60 Hz p_{\min} : 33 mbar abs. / Q_{\max} : 445 m³/h



VG Series

Valveless and low-maintenance

Single-stage pumps without valves, free of dead spots, close-coupled and bracket versions

50 Hz p_{\min} : 40 mbar abs. / Q_{\max} : 200 m³/h

60 Hz p_{\min} : 40 mbar abs. / Q_{\max} : 245 m³/h



VE Series

For suction or compression mode

Single-stage pumps with valve flaps, close-coupled version, excentrics on top

50 Hz p_{\min} : 33 mbar abs. / Q_{\max} : 190 m³/h

60 Hz p_{\min} : 33 mbar abs. / Q_{\max} : 230 m³/h



VN Series

For large quantities of additional liquid

Single-stage pumps with valve flaps and port cylinder, close-coupled and bracket versions

50 Hz p_{\min} : 55 mbar abs. / Q_{\max} : 180 m³/h

60 Hz p_{\min} : 55 mbar abs. / Q_{\max} : 215 m³/h



VU Series

Tried-and-tested robust technology for rough vacuum

Single-stage pumps in base plate version

50 Hz p_{\min} : 120 mbar abs. / Q_{\max} : 1550 m³/h

60 Hz p_{\min} : 120 mbar abs. / Q_{\max} : 1900 m³/h



VZ Series

Robust and low-noise technology for deep vacuum ranges - Two-stage pumps without valves, close-coupled and bracket versions, magnetic couplings on request

50 Hz p_{\min} : 33 mbar abs. / Q_{\max} : 185 m³/h

60 Hz p_{\min} : 33 mbar abs. / Q_{\max} : 225 m³/h



VH Series

Tried-and-tested robust technology for deep vacuum ranges - Two-stage pumps in base plate version without valves

50 Hz p_{\min} : 33 mbar abs. / Q_{\max} : 56 m³/h

60 Hz p_{\min} : 33 mbar abs. / Q_{\max} : 68 m³/h



VHC Series

Innovative technology for deep vacuum ranges - Two-stage pumps in base plate versions without valves

50 Hz p_{\min} : 33 mbar abs. / Q_{\max} : 1600 m³/h

60 Hz p_{\min} : 33 mbar abs. / Q_{\max} : 1700 m³/h

Order-related tests



Computer-controlled and fully automated test stands for vacuum pumps on the premises of Speck in Roth. Measuring of hydraulics, power requirements and vibrations. Test of inlet pressures up to 5 mbar and suction capacities up to 2000 m³/h..

Testing the performance

Speck carries out hydraulic tests as standard.

The measurement of the characteristic curves apply to the delivery of water at nominal speed according to DIN 28431.

The tolerance of the suction capacity is -10 % and of the power consumption +10 %. With different operating conditions characteristic curves change (e.g. differing gas operating liquid conditions, conveying of additional liquids and/or pumping of gas-steam mixtures).

Other tests

At the customer's request, Speck offers the following tests:

Hydrostatic pressure test

The hydrostatic pressure test is used to prove strength of the components and that the pump is leak-proof. The fully assembled pump is tested. If you want to use pressure tests according to different criteria, please enter them in the request.

Vibration test

Vibration test according to EN ISO 5199, Edition 2002 – the vibration values are measured radially and vertically at every operating point on the bearing casing at the nominal speed.

Temperature measurement

The measurement is taken on the motor-side bearing at operating temperature. The operating temperature and the ambient temperature at every operating point measured are documented.

Noise measurement

Scope and procedures in close cooperation with the customer

Representations

- Produktion / Production
- ▣ Vertrieb / Sales
- Service / Service

■ **Speck Pumpen**
Walter Speck GmbH & Co. KG

▣ **Speck Pumpen**
Systemtechnik GmbH

○ **Speck Pumpen**
Vakuumentchnik GmbH

Regensburger Ring 6 - 8, 91154 Roth
T: +49 9171 809 0
F: +49 9171 809 10
info@speck.de
www.speck.de

▣ **Speck Office Nord**
Ingenieure Willy Wandrach GmbH
Flurstraße 105
22549 Hamburg
T: +49 40 398 624 0
F: +49 40 398 624 28
info@speck-nord.de
www.speck-nord.de

▣ **Speck Office Mitte**
Grotian-Steinweg-Str. 1c
38112 Braunschweig
T: +49 531 23 000 90
info@speck-mitte.de
www.speck-mitte.de

▣ **Speck Office West**
Robert-Koch-Straße 22
40764 Langenfeld
T: +49 2173 914 560
info@speck-west.de
www.speck-west.de

▣ **Speck Office Ost**
Dahlener Str. 7a
04889 Belgern-Schildau
T: +49 34221 557 812
info@speck-ost.de
www.speck-ost.de

▣ **Speck Office Südwest**
Frankenstr. 9
67227 Frankenthal
T: +49 6233 354 80 57
info@speck-suedwest.de
www.speck-suedwest.de

○ **IVT-Pumpen GmbH**
Zum Wischfeld 1 A
31749 Auetal
T: +49 5752 929 599
F: +49 5752 929 597
info@ivt-pumpen.de
www.ivt-pumpen.de

○ **FSE Fluid Systems Erfurt**
Poeler Weg 6
99085 Erfurt
T: +49 361 550 715 0
F: +49 361 550 715 19
info@fluidsystems.org
www.fluidsystems.org

○ **Vacuum pumps**
Arpuma GmbH
Ottostrasse 10
50170 Kerpen
T: +49 2273 953 300 0
F: +49 2273 953 300 20
info@arpuma.de
www.arpuma.de

International

A Austria

▣ Tuma Pumpensysteme GmbH
Eitnergasse 12
1230 Wien
T: +43 191 493 40
F: +43 191 414 46
contact@tumpumpen.at
www.tumpumpen.at

AUS Australia

▣ **Speck Pumpen Subsidiary**
Speck Industries Pty Ltd.
Unit 2
6 Glory Road
Gnangara WA 6077
T: 1300 207 380
T: +61 8 6201 1286
sales@speckaustralia.com
www.speckaustralia.com

B Belgium

Heat transfer pumps / Pompes pour fluid thermique
▣ FLOWMOTION BVBA
Mergelweg 3
1730 Asse
T: +32 2 309 67 13
F: +32 2 309 69 13
info@flowmotion.be
www.flowmotion.be

▣ SPECK - Pompen België N.V.
Bierweg 24
9880 Aalter
T: +32 937 530 39
F: +32 932 500 17
info@speckpompen.be
www.speckpompen.be

BG Bulgaria

▣ EVROTECH OOD
54 A, Manastirska Str.
1111 Sofia
T: +359 2 971 32 73
F: +359 2 971 22 88
office@evrotech.com
www.evrotech.com

CH Switzerland

▣ **Speck Pumpen Subsidiary**
Speck Pumpen Industrie GmbH
Bürglenweg 4
8854 Galgenen
T: +41 554 425 094
F: +41 554 425 094
info@speckswitzerland.com
www.speckswitzerland.com

▣ HänyTec AG
Pumpen-Prozesse-Service
Lättfeld 2
6142 Gettnau
T: +41 62 544 33 00
F: +41 62 544 33 10
contact@haenytec.ch
www.haenytec.ch

▣ MEYER ARMATUREN PUMPEN GMBH
Rigackerstrasse 19
5610 Wöhlen
T: +41 56 622 77 33
F: +41 56 622 77 60
info@meyer-armaturen.ch
www.meyer-armaturen.ch

CN China

▣ **Speck Pumpen Subsidiary**
Jiashan SPECK PUMPS
Systemtechnik Ltd.
No. 57, Hong Qiao Rd., Hujin Street
No. 4 Economical Developing Zone,
Zhejiang Province
T: +86 573 847 312 98
F: +86 573 847 312 88
steveche@speck-pumps.cn
www.speck-pumps.cn

CZ Czech Republic

▣ Sigmet spol s.r.o.
Kosmonautu c.p. 1103/6a
77200 Olomouc
T: +420 585 231 070
F: +420 585 227 072
sigmet@sigmet.cz
www.sigmet.cz

DK Denmark

▣ Pumpegruppen a/s
Lundtoftegårdsvej 95
2800 Lyngby
T: +45 459 371 00
F: +45 459 347 55
info@pumpegruppen.dk
www.pumpegruppen.dk

E Spain

▣ **Speck Pumpen Subsidiary**
SPECK BOMBAS INDUSTRIALES,
S.L.U.
Trafalgar, 53 despacho C
Centro de Negocios CNAF
46023 Valencia
T: +34 963 811 094
F: +34 963 811 096
M: +34 618 376 241
ventas@speckbombas.es
www.speck.de

F France

▣ **Speck Pumpen Subsidiary**
Speck Pompes Industries S.A.
Z.I. Parc d'Activités du Ried
4, rue de l'Energie
B.P. 227
67727 Hoerdt Cedex
T: +33 3 88 68 26 60
F: +33 3 88 68 16 86
info@speckpi.fr

GB Great Britain

▣ Speck ABC UK Ltd
AreenA House
Moston Road,
Elworth, Sandbach
Cheshire CW11 3HL
T: +44 844 764 063 2
F: +44 844 764 063 4
admin@speck-abc.com
www.speck-abc.com

GR Greece

▣ SPECK Hellas
Salaminos St. 54
17676 Kallithea
T: +30 210 956 500 6
F: +30 210 957 747 3
grecha@speckhellas.gr

I Italy

Centrifugal pumps / Pompe centrifughe
▣ Speck Industries S.r.l
Via Garibaldi, 53
20010 Canegrate (MI)
T: +39 0331 405 805
M: +39 339 16 59 440
info@speckindustries.it
www.speckindustries.it

Vacuum pumps / Pompe per vuoto

▣ Rio Nanta S.r.l.
Via Mauro Macchi, 42
20124 Milano
T: +39 028 940 642 1
F: +39 028 323 913
M: +39 339 658 781 6
rionanta@rionanta.it
www.rionanta.it

IL Israel

Small pumps /
heat transfer pumps
▣ Ringel Brothers (1973) Ltd.
134 Hertzl St.
P.O. Box 5148
Tel-Aviv 66555
T: +972 368 255 05
F: +972 368 220 41
M: +972 544 623 095
mringel@ringel-bros.co.il
www.ringel-bros.co.il

IND India

▣ Flux Pumps India Pvt. Ltd.
427/A-2, Gultekdi Industrial Estate
Near Prabhat Printing Press
Pune - 411 047, Maharashtra
T: +91 020 2427 1023
F: +91 020 2427 0689
M: +91 98504 03114
kiran.kadam@flux-pumps.in
www.flux-pumps.in

J Japan

▣ Rodatec, Inc.
Suite 301 Oka Bldg.
2 - 1 - 16 Kyomachibori, Nishiku
550 - 0003 Osaka
T: +81 664 441 940
F: +81 664 449 050
info@rodatec.co.jp
www.rodatec.co.jp

▣ Rodatec, Inc.
Tokyo Branch
No. 408, 3 - 22 - 12
Highashi Ikebukuro, Toshima - ku
170-0013 Tokyo
T: +81 359 798 818
F: +81 359 798 817
roda-to@yrim.or.jp
www.rodatec.co.jp

L Luxembourg

Heat transfer pumps / Pompes pour fluid thermique
▣ FLOWMOTION BVBA
Mergelweg 3
1730 Asse
T: +32 2 309 67 13
F: +32 2 309 69 13
info@flowmotion.be
www.flowmotion.be

MAL Malaysia

▣ Leesonmech
Engineering (M) Sdn. Bhd.
No. 18 Jalan 18, Taman Sri Kluang,
86000 Kluang, Johor
T: +607 777 105 5
F: +607 777 106 6
sales@leesonmech.com
www.leesonmech.com

N Norway

▣ PG Flow Solutions AS
P.O.Box 154, 1378 Nesbru
Nye Vakaas Vei 14
1395 Hvalstad
T: +47 667 756 00
F: +47 667 756 01
post@pg-flowsolutions.com
www.pg-flowsolutions.com

NL Netherlands

Centrifugal pumps /
Centrifugaalpompen
▣ Speck Pompen Nederland B.V.
Businesspark 7Poort
Stationspoort 10
6902 KG Zevenaar
T: +31 316 331 757
F: +31 316 528 618
info@speck.nl
www.speck.nl

Vacuum pumps / Vacuumpompen

▣ DOVAC B.V.
Meer en Duin 228
2163 HD Lisse
T: +31 252 423 363
F: +31 252 417 946
info@dovac.nl
www.dovac.nl

Heat transfer pumps / Pompes pour fluid thermique

▣ FLOWMOTION BVBA
Mergelweg 3
1730 Asse
T: +32 2 309 67 13
F: +32 2 309 69 13
info@flowmotion.be
www.flowmotion.be

NZ New Zealand

▣ **Speck Pumpen Subsidiary**
Speck Industries Pty Ltd.
Unit 2
6 Glory Road
Gnangara WA 6077
T: +61 8 6201 1286
sales@speckaustralia.com
www.speckaustralia.com

P Portugal

▣ Ultra Controlo
Projectos Industriais, Lda.
Quinta Lavi - Armazém 8
Abrunheira
27 10 - 089 Sintra
T: +351 219 154 350
F: +351 219 259 002
info@ultra-controlo.com
www.ultra-controlo.com

PL Poland

▣ Krupinski Pompy Spółka z
Ograniczona Odpowiedzialnoscia Sp.K.
ul. Przymiarki 4A
31-764 Krakow
T + F: +48 126 455 684
biuro@krupinski.krakow.pl
www.krupinski.krakow.pl

RC Taiwan

▣ **Speck Pumpen Subsidiary**
Speck Pumps
Technology Taiwan Ltd.
2Fl., no. 159, Sec. 2
Datong Rd., Xizhi District
New Taipei City
T: +886 286 926 220
F: +886 286 926 759
M: +886 936 120 952
speck886@ms32.hinet.net
www.speck-pumps.com.tw

RCH Chile

▣ W & F Ingenieria Y Maquinas S.A.
Feliz de Amesti 90, Piso 6
Las Condes, Santiago
T: +56 2 220 629 43
F: +56 2 220 630 39
M: +56 9 8 289 222 0
rwendler@wyf.cl
www.wyf.cl

RI Indonesia

▣ PT Roda Rollen Indonesia
Kompleks Pertokoan Glodok
Jaya No. 30
Jl. Hayam Wuruk,
Jakarta - Pusat
Indonesia, 11180
T: +6221 659 922 528
F: +6221 380 595 9
rudy@rodarollenindonesia.com

ROK Korea

▣ J.C. International Inc.
2F, Bikeum Bldg, 108,
Yanghwa-Ro, Mapo-Gu,
121-893 Seoul
T: +82 232 628 00
F: +82 232 569 09
jylee@jcint.co.kr
www.jcint.co.kr

RO Romania

▣ S.C. Gimsid S.R.L.
Str. Arcului nr. 9, Arp.2
021031 Bucuresti
T: +40 21 2118701
F: +40 21 2102675
gimsid@gimsid.ro
www.gimsid.ro

RUS Russia

▣ LLC Firm Kreoline
Yunosti str., 5/3
Moscow 111395
T: +7 495 737 321 4
F: +7 495 769 844 0
M: +7 495 505 198 8
info@kreoline.ru
www.kreoline.ru

S Sweden

▣ Hugo Tillquist AB
P.O.Box 1120
16422 Kista
T: +46 859 463 200
F: +46 875 136 95
info@tillquist.com
www.tillquist.com

SK Slovakian Republic

→ Czech Republic (CZ)

SLO Slovenia

▣ SLOTEH Branko Gabric s.p.
Zagrebska cesta 20
2000 Maribor
T: +38 624 614 460
F: +38 624 614 465
branko.gabric@amis.net
www.sloteh.si

SGP Singapore

→ Malaysia (MAL)

T Thailand

▣ **Speck Pumpen Subsidiary**
Pump Systems Flux &
Speck Co. Ltd.
181/4 Soi Anamai
Srinakarim Road
Suanluang Bangkok 10250
T: +662 320 256 7
F: +662 322 248 6
thienchai@fluxspeck.com
www.fluxspeck.com

TR Turkey

▣ Speck Pompa
San. ve Tic. Ltd. Sti.
Girne Mah. Küçükyalı Is Merkezi
B Blok No:12 Maltepe
34852 Istanbul
T: +90 216 375 750 5
F: +90 216 375 753 3
M: +90 532 293 010 4
speck@speckpompa.com.tr
www.speckpompa.com.tr

USA USA

▣ **Speck Pumpen Subsidiary**
Speck Industries LP
301 Veterans Blvd
Rutherford
NJ 07070
T: +1 201 569 3114
F: +1 201 569 9607
info@speckamerica.com
www.speckamerica.com

ZA Rep. South Africa

▣ SPP Pumps SA (Pty) Ltd.
Cnr Horne St & Brine Ave
Kloofkop Ext 23
Kempton Park
1619 Gauteng
R.S.A.
1619
T: +27 11 393 7177
F: +27 86 513 0255
sales@sppumps.co.za
www.sppumps.co.za