



VERDERFLEX®

VERDERFLEX PERISTALTIC PUMPS

Smart S20 - 3 Roller

Any questions? You may still have questions and/or comments after reading this brochure. Please feel free to contact us on +44 (0)1924 221 020. You can also respond via email to info@verderflex.com. For more information about Verderflex please visit our website www.verderflex.com



VERDERFLEX

Unit 3, California Drive, **TEL** +44 (0)1924 221 020
Castleford WF10 5QH **FAX** +44 (0)113 222 0291
United Kingdom **MAIL** info@verderflex.com
WEB www.verderflex.com

AT Wien **BE** Aartselaar **BG** Sofia **CH** Basel **CN** Shanghai **CZ** Praha **DE**
Haan **FR** Eragny s/Oise **GB** Castleford **HU** Budapest **IT** Torre Boldone
JP Tokyo **NL** Groningen/Vleuten **PL** Katowice **RO** Bucuresti/Sibiu
RU St Petersburg **SK** Bratislava **US** Newtown/Macon **ZA** Northriding

S203.EN.0411

VERDER
passion for pumps

Verderflex Smart Tube Pumps | 1

Smart 20 – 3 roller

Physical Properties

Weight	12.5 kg (27.6lb)
Voltage	115V/230V
Frequency	50/60Hz
Power Consumption	250W

Capacity

Tube ID x Wall (mm)	Min ml/min	US GPH	Max ml/min	US GPH
3.2 x 2.4	46	0.7	500	7.6
4.8 x 2.4	70	1.1	900	15.0
6.4 x 2.4	100	1.6	1,600	25.7
8.0 x 2.4	130	2.0	2,200	35.1
9.6 x 2.4	156	2.4	3,200	50.0



Free Flow Curve

Flow rates with water at 20°C (68°F)

The S20 Pump Head is designed to use a 2.4mm (3/32") wall thickness tube

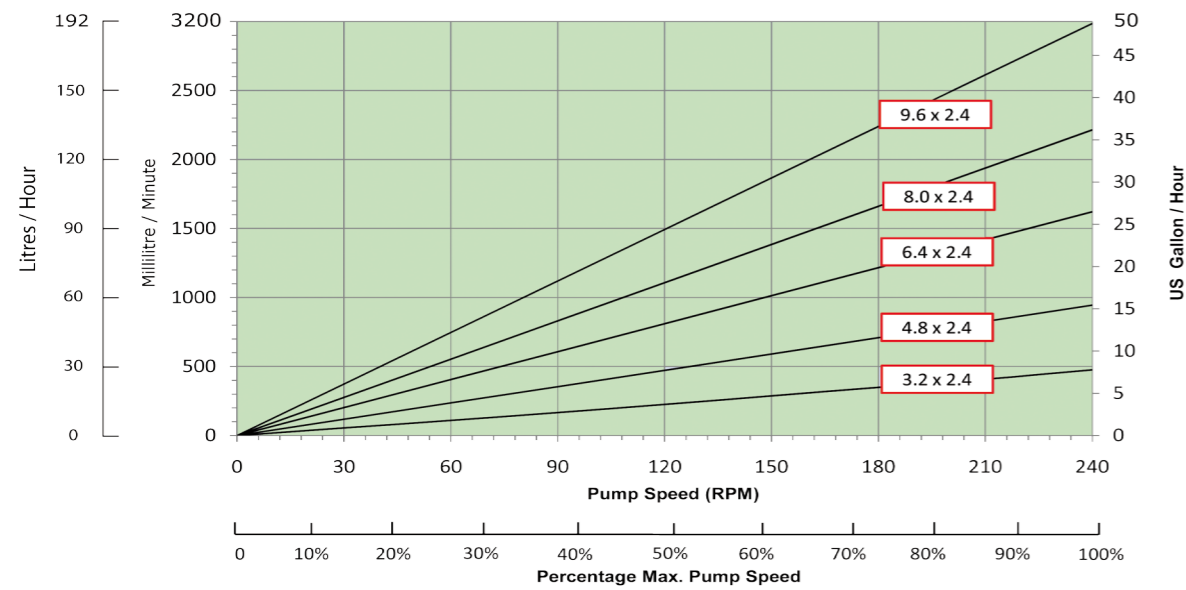

General Arrangement Layout

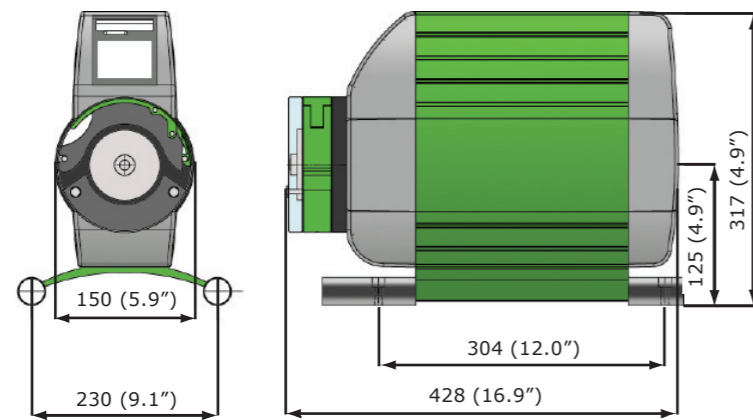

The drawings are for guidance only - all dimensions in millimetres and inches

Suction Loss

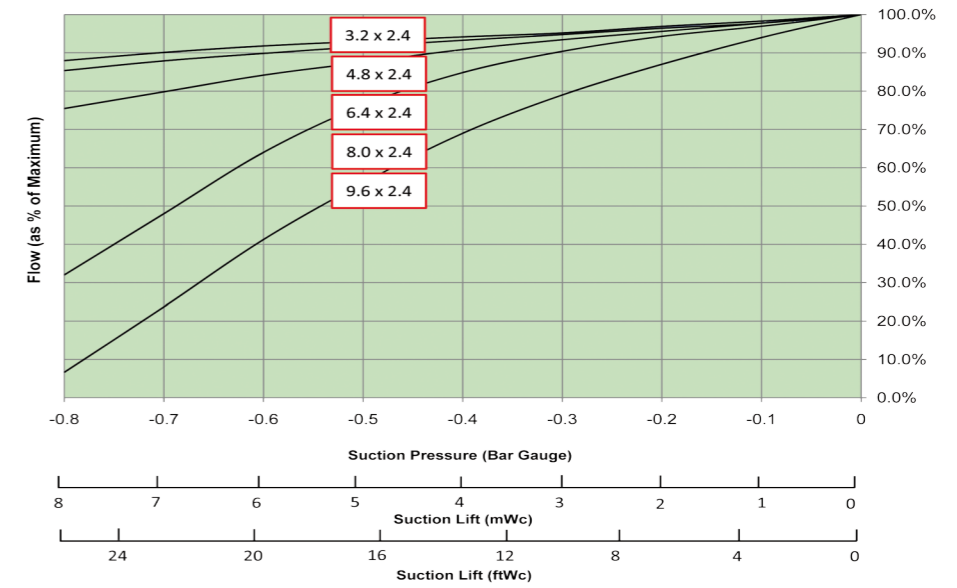

Discharge

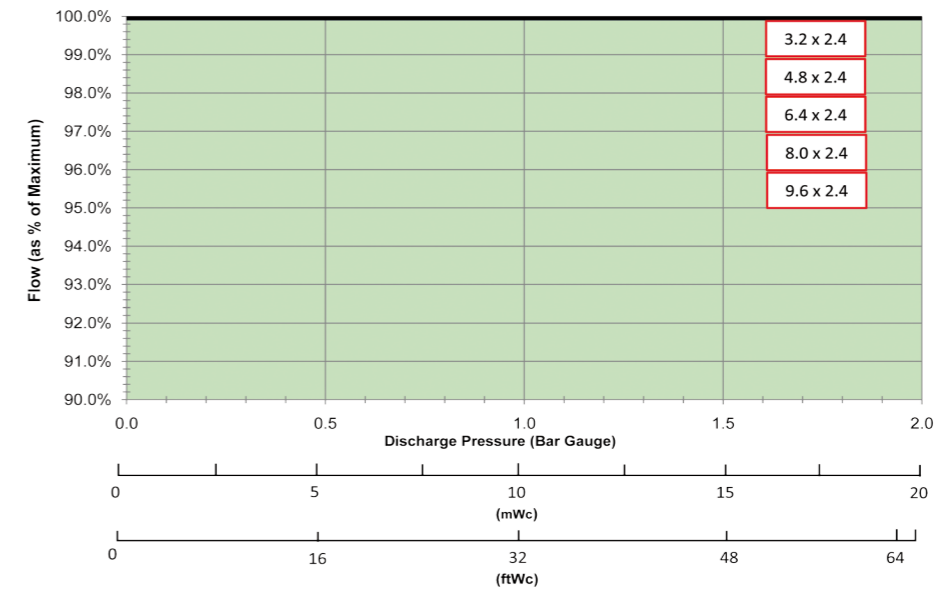

Viscosity

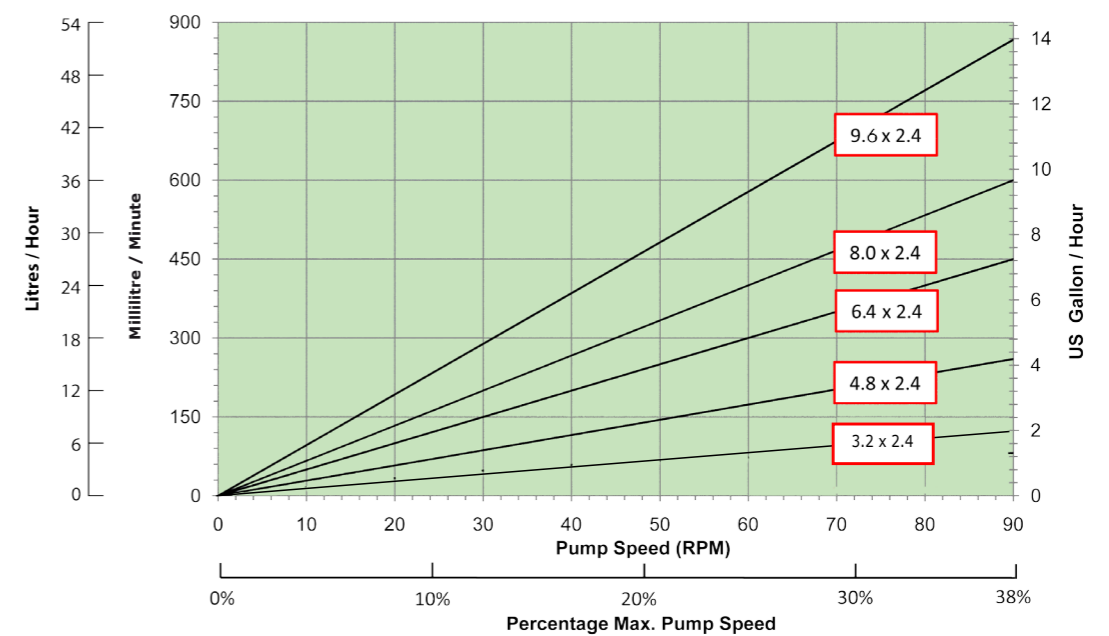

Viscous liquid 350 cps at 22°C