

PULSAR[®] R86 RADAR

Installation and Operating Manual for Pulsar[®] Model R86 with HART[®] output

Software Version 1.x

*High Performance 26 GHz
Pulse Burst Radar
Level Transmitter*



Read this Manual Before Installing

This manual provides information on the Pulsar® Model R86 Radar transmitter. It is important that all instructions are read carefully and followed in sequence. The *QuickStart Installation* instructions are a brief guide to the sequence of steps for experienced technicians to follow when installing the equipment. Detailed instructions are included in the *Complete Installation* section of this manual.

Conventions Used in this Manual

Certain conventions are used in this manual to convey specific types of information. General technical material, support data, and safety information are presented in narrative form. The following styles are used for notes, cautions, and warnings.

NOTES

Notes contain information that augments or clarifies an operating step. Notes do not normally contain actions. They follow the procedural steps to which they refer.

Cautions

Cautions alert the technician to special conditions that could injure personnel, damage equipment, or reduce a component's mechanical integrity. Cautions are also used to alert the technician to unsafe practices or the need for special protective equipment or specific materials. In this manual, a caution box indicates a potentially hazardous situation which, if not avoided, may result in minor or moderate injury.

WARNINGS

Warnings identify potentially dangerous situations or serious hazards. In this manual, a warning indicates an imminently hazardous situation which, if not avoided, could result in serious injury or death.

Safety Messages

The PULSAR Model R86 system is designed for use in Category II, Pollution Degree 3 installations. Follow all standard industry procedures for servicing electrical and computer equipment when working with or around high voltage. Always shut off the power supply before touching any components. Although high voltage is not present in this system, it may be present in other systems.

Electrical components are sensitive to electrostatic discharge. To prevent equipment damage, observe safety procedures when working with electrostatic sensitive components.

This device complies with Part 15 of the FCC rules. Operation is subject to the following two conditions: (1) This device may not cause harmful interference, and (2) This device must accept any interference received, including interference that may cause undesired operation.

FCC ID: LPN-R86

Any unauthorized changes or modifications not expressly approved by the party responsible for compliance could void user's authority to operate this equipment.

WARNING! Explosion hazard. Do not connect or disconnect designs rated Explosion-proof or Non-incendive unless power has been switched off and/or the area is known to be non-hazardous.

Low Voltage Directive

For use in Installations Category II, Pollution Degree 3. If equipment is used in a manner not specified by the manufacturer, protection provided by equipment may be impaired.

Notice of Copyright and Limitations

Magnetrol® & Magnetrol® logotype and Pulsar® are registered trademarks of Magnetrol® International, Incorporated.

Copyright © 2017 Magnetrol® International, Incorporated. All rights reserved.

MAGNETROL reserves the right to make changes to the product described in this manual at any time without notice. MAGNETROL makes no warranty with respect to the accuracy of the information in this manual.

Warranty

All MAGNETROL electronic level and flow controls are warranted free of defects in materials or workmanship for eighteen months from the date of original factory shipment.

If returned within the warranty period; and, upon factory inspection of the control, the cause of the claim is determined to be covered under the warranty; then, MAGNETROL will repair or replace the control at no cost to the purchaser (or owner) other than transportation.

MAGNETROL shall not be liable for misapplication, labor claims, direct or consequential damage or expense arising from the installation or use of equipment. There are no other warranties expressed or implied, except special written warranties covering some MAGNETROL products.

Quality Assurance

The quality assurance system in place at MAGNETROL guarantees the highest level of quality throughout the company. MAGNETROL is committed to providing full customer satisfaction both in quality products and quality service.

The MAGNETROL quality assurance system is registered to ISO 9001 affirming its commitment to known international quality standards providing the strongest assurance of product/service quality available.





Pulsar® Model R86

Pulse Burst Radar Level Transmitter

Table of Contents

1.0 QuickStart Installation		2.6 Configuring the Transmitter.....	20
1.1 Getting Started.....	5	2.6.1 Bench Configuration.....	20
1.1.1 Equipment and Tools.....	5	2.6.2 Menu Traversal and Data Entry.....	21
1.1.2 Configuration Information.....	6	2.6.2.1 Navigating the Menu.....	21
1.2 QuickStart Mounting.....	7	2.6.2.2 Data Selection.....	21
1.2.1 Antenna.....	7	2.6.2.3 Entering Numeric Data Using Digit Entry.....	22
1.2.2 Transmitter.....	7	2.6.2.4 Entering Numeric Data Using Increment/Decrement.....	22
1.3 QuickStart Wiring.....	8	2.6.2.5 Entering Character Data.....	23
1.4 Serup Wizard – Configuration.....	8	2.6.3 Password Protection.....	23
1.4.1 Setup Wizard Menu Options.....	10	2.6.4 Menu: Step-By-Step Procedure.....	24
1.4.1.1 Setup Wizard Numerical Data Entry.....	11	2.6.5 Configuration Menu: Device Setup.....	27
2.0 Complete Installation		2.7 Configuration Using HART®.....	32
2.1 Unpacking.....	12	2.7.1 Connections.....	32
2.2 Electronic Discharge (ESD) Handling Procedure.....	12	2.7.2 Display Menu.....	32
2.3 Before You Begin.....	13	2.7.3 HART Revision Table.....	32
2.3.1 Site Preparation.....	13	2.7.3.1 Model R86.....	32
2.3.2 Equipment and Tools.....	13	2.7.4 HART Menu.....	33
2.3.3 Operational Considerations.....	13	3.0 Reference Information	
2.3.3.1 Maximum Distance.....	14	3.1 Description.....	35
2.3.3.2 Minimum Distance.....	14	3.2 Theory of Operation.....	35
2.3.3.3 Problematic Applications; GWR Alternative.....	14	3.2.1 Pulse Burst Radar.....	35
2.4 Mounting.....	15	3.2.2 Equivalent Time Sampling.....	36
2.4.1 Installing the Antenna.....	15	3.3 Configuration Information.....	36
2.4.1.1 Location.....	15	3.3.1 Bottom Blocking Distance Description.....	36
2.4.1.2 Beam Angle.....	15	3.3.2 Reset Function.....	37
2.4.1.3 Obstructions.....	16	3.3.3 Echo Rejection.....	38
2.4.1.4 Nozzles.....	16	3.3.4 Volumetric Capability.....	38
2.4.1.5 Standpipes and Stillwells.....	16	3.3.4.1 Configuration Using Built-in Vessel Types.....	38
2.4.2 Installing the Transmitter.....	16	3.3.4.2 Configuration Using Custom Table.....	40
2.4.2.1 Low Echo Margin.....	17	3.3.5 Open Channel Flow Capability.....	41
2.5 Wiring.....	18	3.3.5.1 Configuration using Flume/Weir Equations.....	42
2.5.1 General Purpose or Division 2.....	18	3.3.5.2 Configuration using Generic Equation.....	43
2.5.2 Intrinsically Safe.....	19	3.3.5.3 Configuration using Custom Table.....	44
2.5.3 Explosion Proof.....	19		

continued on next page

3.4	Troubleshooting and Diagnostics.....	45
3.4.1	Diagnostics (Namur NE 107).....	45
3.4.2	Diagnostic Indication Simulation.....	47
3.4.3	Diagnostic Help.....	47
3.4.4	Diagnostic Indicator Table.....	49
3.4.5	Additional Diagnostic/Trouble Shooting Capabilities.....	51
3.4.5.1	Echo History Setup.....	51
3.4.5.2	Event History.....	51
3.4.5.3	Context-sensitive Help.....	51
3.4.5.4	Trend Data.....	51
3.5	Agency Approvals.....	52
3.5.1	Agency Drawing & Entity Parameters.....	54
3.6	Specifications.....	57
3.6.1	Functional – Transmitter.....	57
3.6.2	Functional – Environmental.....	58
3.6.2.1	Safe Operating Areas.....	58
3.6.2.2	Supply Voltage.....	59
3.6.3	O-ring (seal) Selection Chart.....	59
3.6.4	Functional – Antenna.....	60
3.6.5	Antenna Pressure/Temperature Ratings.....	60
3.6.6	Operating Temperature Range.....	60
3.6.7	Physical.....	61
3.7	Parts.....	62
3.7.1	Replacement Parts.....	62
3.8	Model Numbers.....	63
3.8.1	PULSAR Model R86 Radar Transmitter.....	63
3.8.2	PULSAR Model R86 Radar Antennas.....	64
4.0	Advanced Configuration/Troubleshooting Techniques	
4.1	Echo Rejection.....	66
4.2	Custom Echo Rejection.....	70
4.3	Tank Profile.....	75
4.4	Echo Margin.....	77
4.5	Automated Echo Capture.....	78
4.6	Event History.....	79

1.0 QuickStart Installation

The QuickStart Installation procedures provide an overview of the key steps for mounting, wiring, and configuring the PULSAR Model R86 radar level transmitter. These procedures are intended for experienced installers of electronic level measurement instruments.

See Section 2.0, *Complete Installation*, for detailed installation instructions.

1.1 Getting Started

Before beginning the QuickStart Installation procedures, have the correct equipment, tools, and information available.

1.1.1 Equipment and Tools

No special tools are required. The following items are recommended:

- Threaded antenna and process connection. 2 $\frac{1}{8}$ " (54 mm) wrench
- Transmitter/antenna connection. 1 $\frac{1}{2}$ " (38 mm) wrench
- Torque wrench. highly desirable
- Flat-blade screwdriver
- Digital multimeter or volt/ammeter. Optional
- 24 VDC (23 mA) power supply. Optional

1.1.2 Configuration Information

A helpful SETUP WIZARD, which will guide you through the simple configuration (with parameter explanations), is available in the PULSAR Model R86. Located in the local user interface menu under MAIN MENU/WIZARDS/SETUP WIZARD, some key information is required for configuration. The transmitter will prompt confirmation questions at the end of the Setup Wizard to verify operation.

Gather the information and complete the following operating parameters table before beginning configuration.

NOTE: These configuration steps are not necessary if the transmitter was pre-configured prior to shipment.

Display	Question	Answer
Measurement Type	What is the intended measurement type (Level, Volume, or Flow)?	_____
System Units	What units of measurement will be used?	_____
Antenna Model	What type of antenna is being used? Select first 3 digits of model number. (See nameplate on side of antenna.)	_____
Antenna Extension	What is maximum nozzle length for which the antenna can be used? Select 8th digit of antenna model number. (See nameplate on side of antenna.)	_____
Antenna Mount	Is the antenna mounting NPT, BSP, or flanged?	_____
Heat Extension	Is there a heat extension connected to the antenna?	_____
Tank Height	What is the tank height?	_____
Stillwell ID	What is the Inner Diameter (ID). Enter 0 if not applicable.	_____
Dielectric Range	What is the dielectric of the process medium?	_____
Turbulence	What amount of turbulence is expected?	_____
Foam	What amount of foam is expected?	_____
Rate of Change	What is the expected maximum rate of level change?	_____
Primary Variable	Select Level, Volume, or Flow	_____
4 mA Setpoint (LRV)	What is the 0% reference point for the 4.0 mA value?	_____
20 mA Setpoint (URV)	What is the 100% reference point for the 20.0 mA value?	_____
PV Alarm Selection	What output current is desired when a failure indicator is present?	_____
Damping	How much damping (averaging) is required? Default = 1 second	_____

1.2 QuickStart Mounting

NOTE: Confirm the configuration style and process connection (size and type) of the PULSAR Model R86 radar transmitter. Ensure it matches the requirements of the installation before continuing with the QuickStart installation.

- ① Confirm the model and serial numbers on the nameplates of PULSAR Model R86 electronics and antenna are identical.

1.2.1 Antenna

- ② Carefully place the antenna into the vessel. Mount in a location equal to $\frac{1}{2}$ the radius of tank top. Do not mount in center of vessel nor closer than 45 cm (18") of tank wall.
- ③ Secure the antenna to the vessel.
- ④ Leave the protective plastic cap in place until ready to install the transmitter.

NOTE: Do not use sealing compound or TFE tape on antenna connection to transmitter. This connection is sealed by a Viton® O-ring.

1.2.2 Transmitter

1. Remove the protective plastic cap from the top of the antenna and store for future use. Make sure the bottom of the Universal connector and inside of the antenna are clean and dry. Clean with isopropyl alcohol and cotton swabs if necessary.
 2. Place the transmitter onto the antenna.
 3. Rotate the transmitter so that it is in the most convenient position for wiring, configuring, and viewing.
 4. While keeping the housing aligned, tighten the large Universal connector Hex nut to 30 ft. lbs (40 N m) of force. A torque wrench is highly desirable.
DO NOT LEAVE HAND TIGHT.
- Do not place insulating material around any part of the Radar transmitter including the antenna flange.

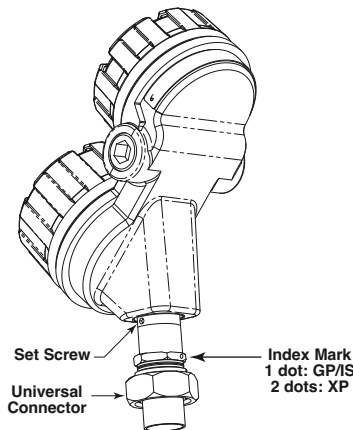

1.3 QuickStart Wiring

WARNING! Explosion hazard. Do not remove covers unless power has been switched off or the area is known to be non-hazardous.

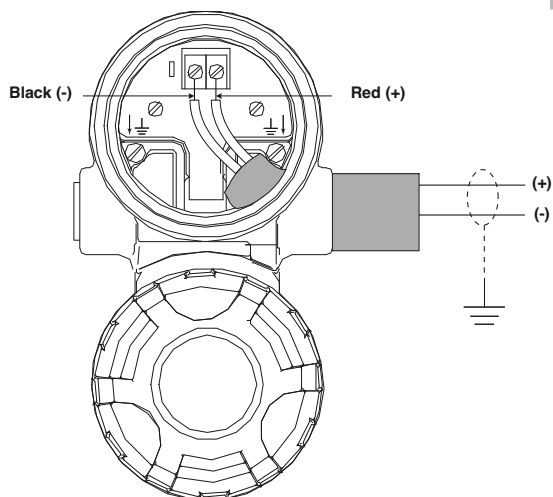

NOTE: Ensure that the electrical wiring to the PULSAR Model R86 radar transmitter is complete and in compliance with all regulations and codes.

1. Remove the cover of the upper wiring compartment.
2. Attach a conduit fitting and mount the conduit plug in the spare opening. Pull the power supply wire through the conduit fitting.
3. If present, connect cable shield to an earth ground at the power supply.
4. Connect the positive supply wire to the (+) terminal and the negative supply wire to the (-) terminal. For Explosion Proof Installations, see *Wiring*, Section 2.5.3.
5. Replace the cover and tighten.

1.4 Setup Wizard – Configuration

If requested, the PULSAR Model R86 transmitter is shipped fully pre-configured for the application and can be installed immediately. Otherwise, the unit is shipped configured with default factory values and can be easily reconfigured in the shop. The minimum configuration instructions follow. Use the information from the operating parameters table before beginning configuration. See Section 1.1.2, *Configuration Information*.

The Setup Wizard offers a very simple step-by-step menu indicating the basic parameters required for a typical application.

1. Apply power to the transmitter.
The graphic LCD display can be programmed to change every two seconds to show pertinent Measured Values on the Home Screen. For example: Level, %Output, and Loop current can all be displayed on a rotating screen.
The LCD can also be programmed to always show just one of the Measured Variables at all times. For example: Level can be the only value displayed on the screen.
2. Remove the cover of the electronics compartment.



STEP 4



3. The push buttons offer multiple forms of functionality for menu navigation and data entry. (See Section 2.6 for complete explanation.)

- ↑ **UP** moves up through the menu or increases a displayed value.
- ↓ **DOWN** moves down through the menu or decreases a displayed value.
- ↶ **BACK** exits a branch of the menu or exits without accepting entered value.
- ↵ **ENTER** enters a branch of the menu or accepts a displayed entry.

NOTE: Holding down the ENTER key for two seconds when any menu or parameter is highlighted will show help text in reference to that item.

STEP 5



- 4. Press any key at the Home Screen to access the Main Menu.
- 5. Press ↵ ENTER with the WIZARDS menu item highlighted.
- 6. Press ↵ ENTER with the SETUP WIZARD menu item highlighted.

The Setup Wizard shows the basic parameters, along with Help Text to guide the procedure.

One can now quickly and easily scroll through the Setup Wizard configuration items, changing those parameters as required:

- Press ↵ ENTER at the highlighted parameter.
- Scroll to the desired option, then press ↵ ENTER.
- Scroll to next parameter or press ↶ BACK when finished to exit the WIZARDS menu.

Section 1.4.1 lists and describes the nine parameters in the SETUP WIZARD menu.

STEP 6



- 7. After making all of the necessary changes in the WIZARDS menu, press the ↶ BACK button three times to return to the Home Screen.
- 8. The QuickStart configuration is complete. The Model R86 transmitter should be measuring and is ready for service.

1.4.1 Setup Wizard Menu Options

Level Units	Select the Units of measurement for the level output: <ul style="list-style-type: none"> • Inches • Feet • Millimeters • Centimeters • Meters 	
Tank Height	Enter tank height (in Level Units selected)	
Antenna Model	<ul style="list-style-type: none"> • RB1-x — 1½" horn • RB2-x — 2" horn • RB3-x — 3" horn • RB4-x — 4" horn 	
Antenna Extension	<ul style="list-style-type: none"> 0 No nozzle 1 For nozzle height ≤ 100 mm (4") 2 For nozzle height ≤ 200 mm (8") 3 For nozzle height ≤ 300 mm (12") 4 For nozzle height ≤ 600 mm (24") 5 For nozzle height ≤ 1200 mm (48") 6 For nozzle height ≤ 1800 mm (72") 	
Antenna Mount	Select the type of Antenna Mounting to the vessel (refer to antenna nameplate): <ul style="list-style-type: none"> • NPT (National Pipe Thread) • BSP (British Standard Pipe) • Flange (ANSI or DIN) 	
Dielectric Range	Enter the Dielectric Range for the material to be measured. Below 1.7 (light hydrocarbons like propane and butane; stillwell only) 1.7 to 3.0 (most typical hydrocarbons) 3.0 to 10 (varying dielectric, for example: mixing tanks) Above 10 (water-based media)	
HART Only	4 mA Set Point (LRV)	Enter the level value (0%-point) for the 4 mA point. Lower Range Value (LRV). Refer to Section 1.4.1.1.
	20 mA Set Point (URV)	Enter the level value (100%-point) for the 20 mA point. Upper Range Value (URV). Refer to Section 1.4.1.1.
	PV Alarm Selection	Enter the desired output state when a Failure Indicator is active. <ul style="list-style-type: none"> • High (22 mA) • Low (3.6 mA) • Hold (hold last value is not recommended for standard configuration). Consult factory.

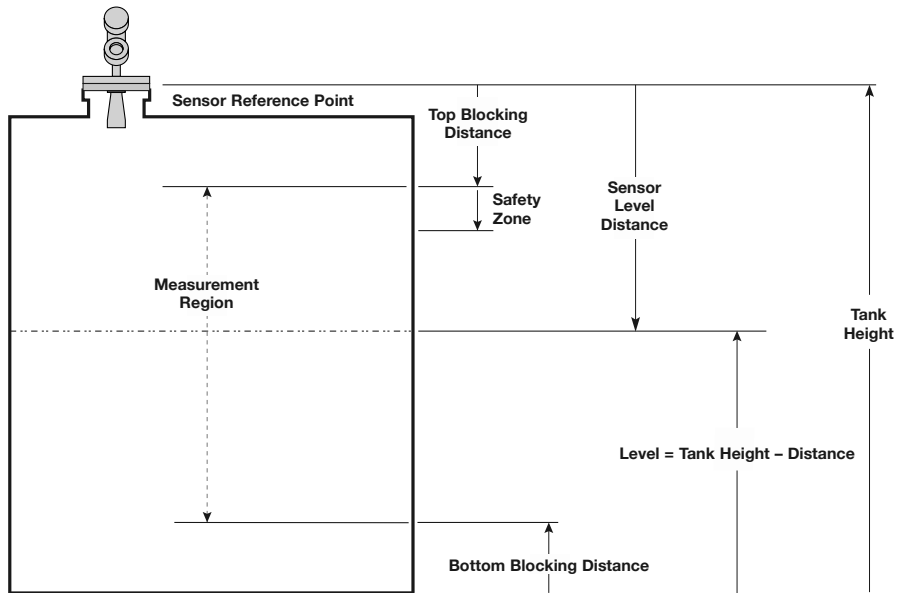

1.4.1.1 Setup Wizard Numerical Data Entry

To make numerical entry changes to Tank Height:

- ⬆ **UP** moves up to the next highest digit (0,1,2,3,....,9 or the decimal point).
If held down the digits scroll until the push button is released.
- ⬇ **DOWN** moves up to the next lowest digit (0,1,2,3,....,9 or the decimal point). If held down the digits scroll until the push button is released.
- ⬅ **BACK** moves the cursor to the left and deletes a digit.
If the cursor is already at the leftmost position, then the screen is exited without changing the previously saved value.
- ➡ **ENTER** Moves the cursor to the right. If the cursor is located at a blank character position, the new value is saved.

Scrolling further in the SETUP WIZARD menu results in the remaining parameters appearing one by one, with the present highlighted value shown at the bottom of the screen.

- ⬅ **BACK** returns to the previous menu without changing the original value, which is immediately redisplayed.
- ➡ **ENTER** accepts the displayed value and returns to the previous menu.

2.0 Complete Installation

This section provides detailed procedures for properly installing, wiring, configuring, and, as needed, troubleshooting the PULSAR Model R86 Radar Level Transmitter.

2.1 Unpacking

Unpack the instrument carefully. Make sure all components have been removed from the packing material. Check all contents against the packing slip and report any discrepancies to the factory.

Before proceeding with the installation, do the following:

- Inspect all components for damage. Report any damage to the carrier within 24 hours.
- Make sure the nameplate model number on the antenna and transmitter agree with the packing slip and purchase order.
- To avoid moisture ingress in the housing, covers should be fully tightened at all times. For the same reason, plugs should remain properly installed in the cable entries until replaced with a cable gland
- Record the model and serial numbers for future reference when ordering parts.

Model Number

Serial Number

2.2 Electrostatic Discharge (ESD) Handling Procedure

MAGNETROL electronic instruments are manufactured to the highest quality standards. These instruments use electronic components that may be damaged by static electricity present in most work environments.

The following steps are recommended to reduce the risk of component failure due to electrostatic discharge.

- Ship and store circuit boards in anti-static bags. If an anti-static bag is not available, wrap the board in aluminum foil. Do not place boards on foam packing materials.
- Use a grounding wrist strap when installing and removing circuit boards. A grounded workstation is recommended.
- Handle circuit boards only by the edges. Do not touch components or connector pins.
- Make sure that all electrical connections are completely made and none are partial or floating. Ground all equipment to a good, earth ground

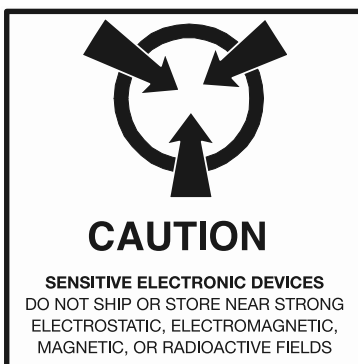

WARNING! Potential electrostatic charging hazard. Do not rub with dry cloth.

2.3 Before You Begin

2.3.1 Site Preparation

Each PULSAR Model R86 Radar transmitter/antenna is built to match the physical specifications of the required installation. Ensure that the antenna process connection is correct for the threaded or flanged mounting on the vessel where the transmitter will be placed. See Section 2.4, *Mounting*.

Ensure that all local, state, and federal regulations and guidelines are observed. See Section 2.5, *Wiring*.

Ensure that the wiring between the power supply and PULSAR Model R86 Radar transmitter is complete and correct for the type of installation. See Section 3.6, *Specifications*.

2.3.2 Equipment and Tools

No special tools are required. The following items are recommended:

- Threaded antenna and process connection. 2 $\frac{1}{8}$ " (54 mm) wrench
- Transmitter/antenna connection. 1 $\frac{1}{2}$ " (38 mm) wrench
- Torque wrench. highly desirable
- Flat-blade screwdriver
- Digital multimeter or volt/ammeter. Optional
- 24 VDC (23 mA) power supply. Optional

2.3.3 Operational Considerations

Radar applications are characterized by three basic conditions;

- Dielectric (process medium)
- Distance (measuring range)
- Disturbances (turbulence, foam, false targets, multiple reflections and rate of change).

The PULSAR Model R86 Radar transmitter is offered with a horn antenna configuration—Horn (1 $\frac{1}{2}$ ", 2", 3", 4"). Ideally, if the installation allows, the 4" horn antenna should be used to ensure the best possible performance in all operational conditions.

2.3.3.1 Maximum Distance

The chart below shows the maximum measuring range (Distance) of each antenna based on fundamental conditions of Dielectric, Distance and Turbulence. Distance is measured from the Sensor Reference Point (bottom of NPT thread, top of BSP thread or face of a flange).

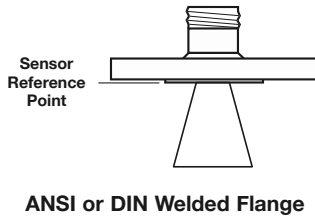

R86 Maximum Recommended Measuring Range in meters (feet)							
Antenna	Dielectric >	Turbulence None or Light			Turbulence Medium or Heavy		
		1.7 – 3	3 – 10	10 – 100	1.7 – 3	3 – 10	10 – 100
1½" Horn		9 (30)	12 (40)	18 (60)	3 (10)	5 (16)	8 (26)
2" Horn		10 (33)	15 (49)	20 (66)	3 (10)	6 (20)	10 (33)
3" Horn		15 (50)	20 (66)	30 (98)	4 (13)	9 (30)	12 (40)
4" Horn		20 (66)	30 (98)	40 (130)	7 (23)	12 (40)	15 (50)

2.3.3.2 Minimum Distance

If the liquid level is allowed onto the antenna, noise and media build-up drastically decrease reliable measurement. Liquid should not be allowed closer than 50 mm (2") from the bottom of the antenna or 300 mm (12") from the sensor reference point, whichever is greater.

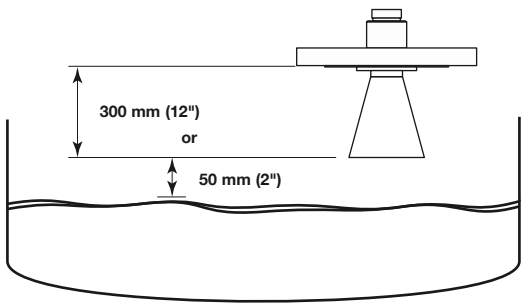

2.3.3.3 Problematic Applications; GWR Alternative

Some applications can be problematic for Non-Contact Radar. For these, Guided Wave Radar is recommended:

- Extremely low dielectric media ($\epsilon_r < 1.7$)
- Stillwells, standpipes, bridles, cages and bypass columns.
- Very weak reflections from the liquid surface (particularly during turbulence) can cause poor performance.
- Tanks heavily cluttered with false targets (mixers, pumps, ladders, pipes, etc.)
- During times of very low liquid levels of low dielectric media, the metal tank bottom may be detected which can deteriorate performance.
- Foam can either absorb or reflect the microwave energy depending upon the depth, dielectric, density and wall thickness of the bubbles. Due to typical variations in the amount (depth) of foam, it is impossible to quantify performance. It may be possible to receive most, some or none of the transmitted energy.
- When measurement close to flange is critical
 - Extremely high liquid levels (Overflow) conditions when liquid very near the antenna can cause erroneous readings and measurement failure.
- Interface applications

Refer to Eclipse® Model 706 bulletin BE 57-106 for additional information.

2.4 Mounting

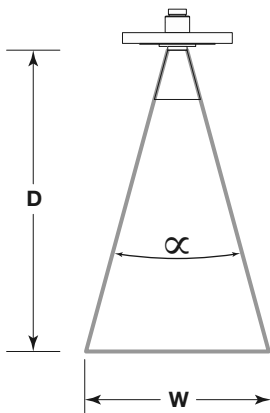
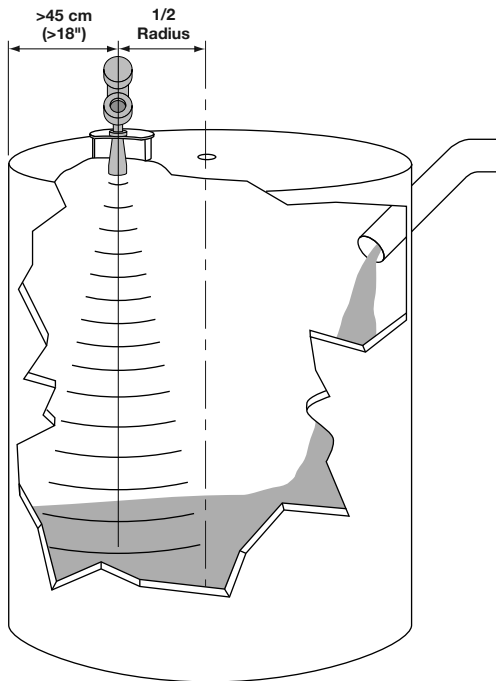

Antenna Beam Angle (α)	Beam Spread, W @-3dB; m (ft)			
	1½" Horn 20°	2" Horn 18°	3" Horn 11°	4" Horn 9°
Distance, D ; m (ft)				
3 (10)	1,1 (3.5)	1,0 (3.2)	0,6 (1.9)	0,5 (1.6)
6 (20)	2,1 (7.1)	1,9 (6.3)	1,2 (3.9)	0,9 (3.1)
9 (30)	3,2 (10.6)	2,9 (9.5)	1,7 (5.8)	1,4 (4.7)
12 (40)	4,2 (14.1)	3,8 (12.7)	2,3 (7.7)	1,9 (6.3)
15 (50)	5,3 (17.6)	4,8 (15.8)	2,9 (9.6)	2,4 (7.9)
18 (60)	6,3 (21.2)	5,7 (19.0)	3,5 (11.6)	2,8 (9.4)
20 (65)		6,3 (20.6)	3,9 (12.5)	3,1 (10.2)
30 (98)			5,8 (18.9)	4,7 (15.4)
40 (130)				6,3 (20.5)

The PULSAR Model R86 Radar transmitter can be mounted to a vessel using a variety of process connections. Generally, either a threaded or flanged connection is used. For information about the sizes and types of connections available, see Section 3.8.2, *Antenna Model Numbers*.

2.4.1 Installing the Antenna

Before installing, ensure that:

- Model and Serial numbers on the nameplates of the PULSAR Model R86 transmitter and antenna are identical.
- Process temperature, pressure, dielectric, turbulence and distance are within the antenna specifications for the installation.
- Protective cap is kept on the antenna if the transmitter is to be installed at a later time.
- Antenna is being mounted in the optimal location. See following sections: *Location*, *Beam Angle*, *Obstructions* and *Nozzles* for specific information.
- If the liquid level comes in contact with the antenna, noise and media buildup drastically decrease reliable measurement. Liquid should not be allowed closer than 50 mm (2") from the bottom of the antenna or 300 mm (12") from the sensor reference point, whichever is greater.

2.4.1.1 Location

Ideally, the Radar transmitter should be mounted providing an unobstructed signal path to the liquid surface where it should illuminate (with microwave energy) the largest, possible surface area. See Section 2.4.1.2, *Beam Angle*. Unavoidable obstacles will produce reflections that must be minimized during field configuration. See Section 3.3.3, *Echo Rejection*. Mount in a location equal to ½ the radius of tank top. Do not mount in center of vessel nor closer than 45 cm (18") of tank wall. Contact Magnetrol Technical Support when mounting closer than 45 cm (18") is required.

2.4.1.2 Beam Angle

The various horn antennas exhibit slightly different beam patterns. Ideally, the beam pattern should illuminate with microwave beam the maximum liquid surface with minimum contact with other objects in the vessel including the tank wall. Use the chart at left to determine the optimum installation location.

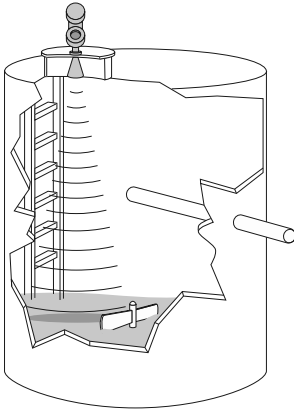

2.4.1.3 Obstructions

Almost any object that falls within the beam pattern will cause reflections that may be misinterpreted as a false liquid level. Although PULSAR Model R86 has a powerful Echo Rejection routine, all possible precautions should be taken to minimize false target reflections with proper installation and orientation. Refer to Section 4.0, *Advanced Configuration/ Troubleshooting Techniques* for additional information.

2.4.1.4 Nozzles

Improper installation in a nozzle can create “ringing” that will adversely affect measurement. The antenna should always be mounted so the active section of the antenna is a minimum of 13 mm (0.5”) outside the nozzle. Antenna extensions are offered to allow the PULSAR Model R86 transmitter to work reliably in nozzles up to 1,8 m (72”). See Section 3.6.7 for dimensional drawings of all antenna designs including nozzle extensions.

Be sure to include any nozzle distance extending within the vessel.

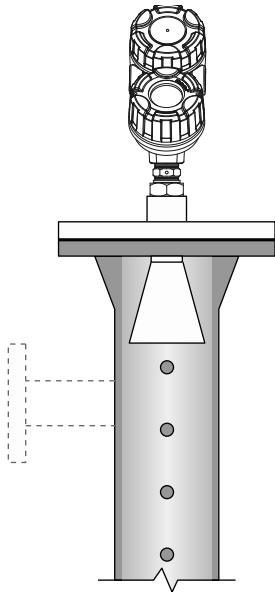
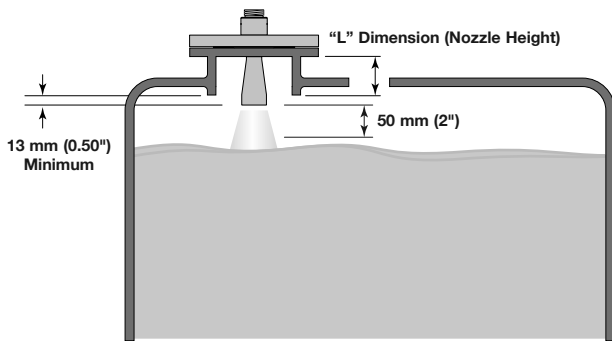

PULSAR Model R86 Mounted in Stillwell (Bridle)

2.4.1.5 Standpipes and Stillwells

The PULSAR Model R86 can be mounted in a standpipe or stillwell but certain items must be considered:

- Metal stillwells only: inside diameter 45–100 mm (1¾”–4”).
- Diameter must be consistent throughout length; no reducers or gaps.
- Stillwell length must cover complete range of measurement (i.e., liquid must be in stillwell).
- Welds should be smooth.
- Vents: holes < 3 mm (0.125”) diameter, slots < 3 mm (0.125”) width.
- If an isolation valve is used, it must be a full port ball valve with an I.D. equal to the pipe diameter.
- Configuration must include a non-zero entry for PIPE I.D parameter.

2.4.2 Installing the Transmitter

- Remove the protective plastic cap from the top of antenna. Store the cap in a safe place in case the transmitter has to be removed later.
- Carefully place the transmitter on the antenna.
- Rotate the transmitter to face the most convenient direction for wiring, configuration and viewing.

NOTE: ALWAYS RUN THE ECHO REJECTION ROUTINE AFTER MAKING CHANGES TO MENU ITEMS (**Antenna Model, Antenna Extension, Antenna Mount, Tank Height, Blocking Distance, Dielectric, Turbulence, Rate of Change, Foam**).

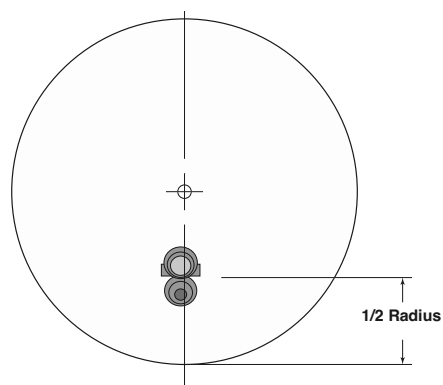

**Top View
Mounted $\frac{1}{2}$ radius**

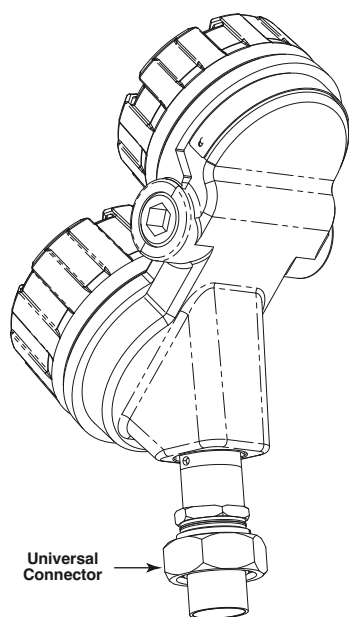

2.4.2.1 Low Echo Margin

Echo Margin is a parameter that, when used with Echo Strength, can be a very useful troubleshooting tool. It is defined as a numeric value that is related to the strength of the target peak relative to the Level Threshold or competing waveform features, i.e., noise.

Echo Loss: If the Level signal is lost repeatedly at a specific point in the vessel, it is usually a symptom of multipath (side-wall) reflections causing cancellation by returning to the transmitter exactly 180° out of phase with the actual Level signal. This can be improved by applying the following procedure:

- Scroll to Display Config Menu under Device Setup. Scroll down to Echo Strength and Echo Margin and change the settings from Hide to View. This will allow you to view these values from the home screen.
- Bring the Level up (or down) to the exact point where the signal is repeatedly lost. Monitor the Echo Margin value as this point is being approached. The Echo Margin value will degrade to a low point before it begins to increase.
- Refer to Section 4.4 for additional information.

2.5 Wiring

Caution: HART versions of the PULSAR Model R86 transmitter operate at voltages of 11–36 VDC. FOUNDATION fieldbus™ versions operate at 9–17.5 VDC. Higher voltages will damage the transmitter.

Wiring connections between the power supply and the PULSAR Model R86 Radar Transmitter should be made using 0.5–1 mm² (18–22 AWG) shielded twisted pair instrument cable. Connections are made to the terminal strip and the ground connections within the top enclosure compartment. Wiring connections are to be torqued to a minimum of 0,79 N m (7 in. lbs.) and shall not exceed 1,13 N m (10 in. lbs.).

The instructions for wiring the PULSAR Model R86 transmitter depend on the application:

- General Purpose or Division 2
- Intrinsically Safe
- Explosion Proof

WARNING! Explosion hazard. Do not disconnect equipment unless power has been switched off or the area is known to be non-hazardous.

To avoid moisture ingress in the housing, covers should be fully tightened at all times. For the same reason, cable gland and plugs should be properly installed in the cable entries.

2.5.1 General Purpose or Division 2

A general purpose installation does not have flammable media present.

Areas rated Division 2 have flammable media present only under abnormal conditions.

24 VDC electrical connections are required.

Caution: If flammable media is contained in the vessel, the transmitter must be installed per Class I, Div 1 standards of area classification.

To install General Purpose or Division 2 wiring:

1. Remove the cover from the wiring compartment of the transmitter. Install the conduit plug in the unused opening and use PTFE tape/sealant to ensure a liquid-tight connection.
2. Install a conduit fitting and pull the supply wires.
3. Connect shield to an earth ground at power supply.
4. Connect an earth ground wire to the nearest green ground screw (not shown in illustration).
5. Connect the positive supply wire to the (+) terminal and the negative supply wire to the (-) terminal.
6. Replace and tighten the cover to the transmitter wiring compartment before applying power.

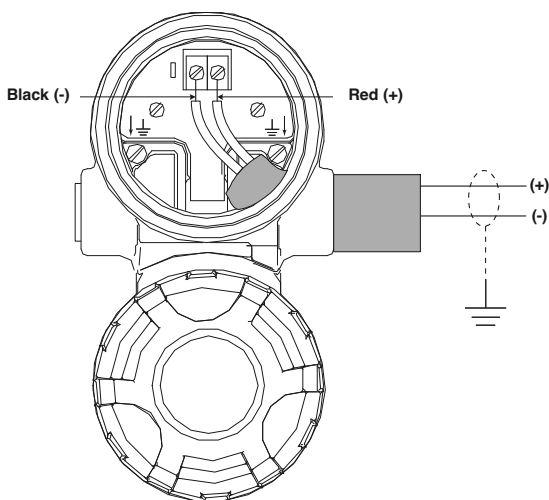

2.5.2 Intrinsically Safe

An Intrinsically Safe (IS) installation potentially has flammable media present. An approved IS barrier must be installed in the non-hazardous (safe) area to limit the available energy out to the hazardous area.

See *Agency Drawing – Intrinsically Safe Installation*, Section 3.5.1.

To install Intrinsically Safe wiring:

1. Ensure that the IS barrier is properly installed in the safe area (refer to local plant or facility procedures). Complete the wiring from the power supply to the barrier and from the barrier to the PULSAR Model R86 transmitter.
2. Remove the cover from the wiring compartment of the transmitter. Install the conduit plug in the unused opening and use PTFE tape/sealant to ensure a liquid-tight connection.
3. Install a conduit fitting and pull the supply wires.
4. Connect shield to an earth ground at power supply.
5. Connect an earth ground wire to the nearest green ground screw (not shown in illustration).
6. Connect the positive supply wire to the (+) terminal and the negative supply wire to the (-) terminal.
7. Replace and tighten the cover to the wiring compartment of the transmitter before applying power.

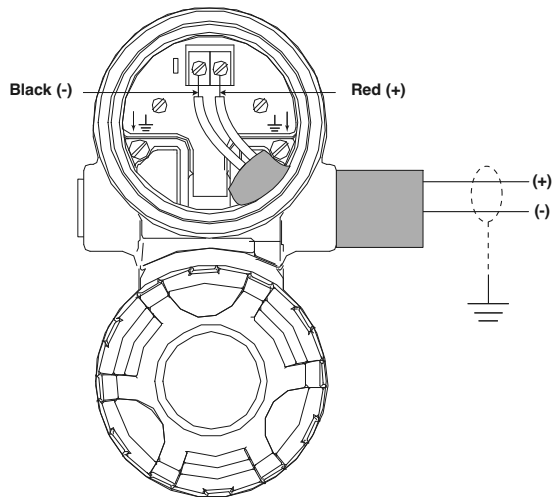

2.5.3 Explosion Proof

Explosion Proof (also referred to as XP or flameproof) is another method of designing equipment for installation into hazardous areas. A hazardous location is an area in which flammable gases or vapors are (or may be) present in the air in quantities sufficient to produce explosive or ignitable mixtures.

The wiring for the transmitter must be contained in Explosion Proof conduit extending into the safe area.

- Due to the specialized design of the PULSAR Model R86 transmitter, no Explosion Proof conduit fitting (EY seal) is required within 45 cm (18") of the transmitter.
- An Explosion Proof conduit fitting (EY seal) is required between the hazardous and safe areas. See Section 3.5, Agency Specifications.

To install an Explosion Proof transmitter:

1. Install Explosion Proof conduit from the safe area to the conduit connection of the PULSAR Model R86 transmitter (refer to local plant or facility procedures).
2. Remove the cover from the wiring compartment of the transmitter.
3. Connect shield to an earth ground at the power supply.
4. Connect an Earth ground wire to the nearest green ground screw per local electrical code (not shown in illustration).
5. Connect the positive supply wire to the (+) terminal and the negative supply wire to the (-) terminal.
6. Replace and tighten the cover to the wiring compartment of the transmitter before applying power.

2.6 Configuring the Transmitter

Although the PULSAR Model R86 transmitter can be delivered pre-configured from the factory, it can also be easily reconfigured in the shop or at the installation using the local LCD/Keypad or PACTware/DTM. Bench configuration provides a convenient and efficient way to set up the transmitter before going to the tank site to complete the installation.

Before configuring any transmitter, collect all operating parameters information (refer to Section 1.1.2).

Apply power to the transmitter and follow the step-by-step procedures for the menu-driven transmitter display. Refer to Sections 2.6.2 and 2.6.4.

Information on configuring the transmitter using a HART communicator is given in Section 2.7, *Configuration Using HART*.

Refer to I/O manual BE 58-641 for information on FOUNDATION fieldbus output.

2.6.1 Bench Configuration

The PULSAR Model R86 transmitter can be easily configured at a test bench by connecting a standard 24 VDC power supply directly to the transmitter terminals as shown in the accompanying diagram. An optional digital multimeter is shown in the event that mA current measurements are desired.

NOTE: Current measurements taken at these test points are an approximate value. Accurate current readings should be taken with the digital multimeter directly in series with the loop.

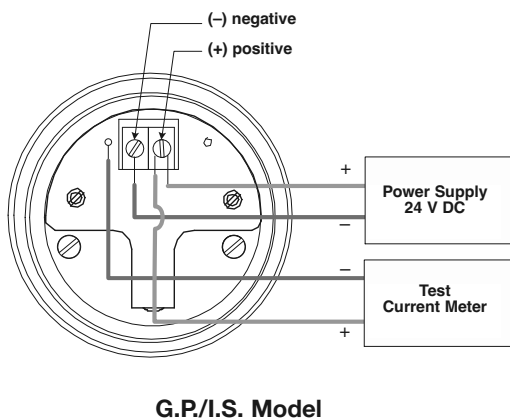

NOTE: When using a HART communicator for configuration, a minimum 250-ohm line load resistance is required. Refer to your HART communicator manual for additional information.

NOTE: The transmitter can be configured without the antenna attached. Disregard any diagnostic indicators that may appear during that time.

2.6.2 Menu Traversal and Data Entry

The four push buttons offer various forms of functionality for navigation and data entry.

The PULSAR Model R86 user interface is hierarchical in nature, best described as a tree structure. Each level in the tree contains one or more items. Items are either menu labels or parameter names.

- Menu labels are presented in all capital letters
- Parameters are capital words

2.6.2.1 Navigating the Menu

- ⇧ **UP** moves to the previous item in the menu branch.
- ⇩ **DOWN** moves to the next item in the menu branch.
- ⇐ **BACK** moves back one level to the previous (higher) branch item.
- ⇒ **ENTER** enters into the lower level branch or switches to the entry mode. Holding the ENTER down on any highlighted menu name or parameter will show help text for that item.

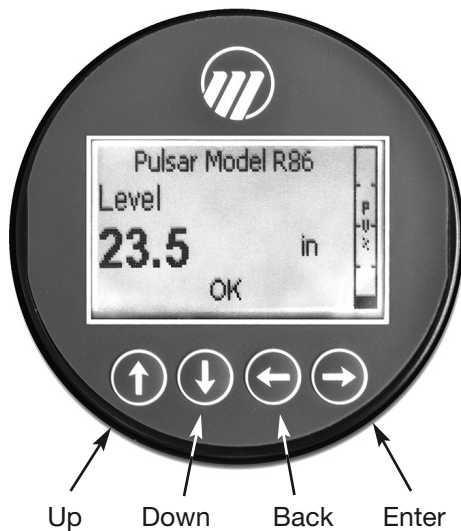

2.6.2.2 Data Selection





This method is used for selecting configuration data from a specific list.

- ⇧ **UP** and ⇩ **DOWN** to navigate the menu and highlight the item of interest
- ⇒ **ENTER** allows modification of that selection
- ⇧ **UP** and ⇩ **DOWN** to choose new data selection
- ⇒ **ENTER** to confirm selection

Use ⇐ **BACK** (Escape) key at any time to abort the procedure and escape to previous branch item

2.6.2.3 Entering Numeric Data Using Digit Entry

This method is used to input numeric data, e.g., Tank Height, 4 mA setpoint and 20 mA setpoint.





Push button		Keystroke Action
	Up	Moves up to the next highest digit (0,1,2,3,....,9 or decimal point). If held down the digits scroll until the push button is released.
	Down	Moves up to the next lowest digit (0,1,2,3,....,9 or decimal point). If held down the digits scroll until the push button is released.
	Back	Moves the cursor to the left and deletes a digit. If the cursor is already at the leftmost position, then the screen is exited without changing the previously saved value.
	Enter	Moves the cursor to the right. If the cursor is located at a blank character position, the new value is saved.

All numeric values are left-justified, and new values are entered from left to right. A decimal point can be entered after the first digit is entered, such that .9 is entered as 0.9.

Some configuration parameters can have a negative value. In this case, the leftmost position is reversed for the sign (either "-" for a negative value, or "+" for a positive value).

2.6.2.4 Entering Numeric Data Using Increment/Decrement





Use this method to input the following data into parameters such as Damping and Failure Alarm.

Push button		Keystroke Action
	Up	Increments the displayed value. If held down the digits scroll until the push button is released. Depending on which screen is being revised, the increment amount may increase by a factor of 10 after the value has been incremented 10 times.
	Down	Decrements the displayed value. If held down the digits scroll until the push button is released. Depending on which screen is being revised, the decrement amount may increase by a factor of 10 after the value has been decremented 10 times.
	Back	Returns to the previous menu without changing the original value, which is immediately redisplayed.
	Enter	Accepts the displayed value and returns to the previous menu.

2.6.2.5 Entering Character Data

This method is used for parameters requiring alphanumeric character entry, such as for entering tags, etc.

General Menu Notes:

Push button		Keystroke Action
	Up	Moves to the previous character (Z...Y...X...W). If held down, the characters scroll until the push button is released.
	Down	Moves to the next item character (A...B...C...D). If held down, the characters scroll until the push button is released.
	Back	Moves the cursor back to the left. If the cursor is already at the leftmost position, then the screen is exited without changing the original tag characters.
	Enter	Moves the cursor forward to the right. If the cursor is at the rightmost position, then the new tag is saved.

2.6.3 Password Protection

The PULSAR Model R86 transmitter has three levels of password protection to restrict access to certain portions of the menu structure that affect the operation of the system.

User Password

The User Password allows the customer to limit access to the basic configuration parameters.

The default User Password installed in the transmitter at the factory is 0. With a password of 0, the transmitter is no longer password protected and any value in the basic user menus can be adjusted without entering a confirming password.

The user password can be changed to any numerical value up to 59999. When the transmitter is programmed for password protection, a password is required whenever configuration values are changed.

NOTE: If a User Password is not known or has been misplaced, the menu item New Password in the DEVICE SETUP/ADVANCED CONFIG menu displays an encrypted value representing the present password. Contact Technical Support with this encrypted password to retrieve the original User Password.

Advanced Password

Certain portions of the menu structure that contain more advanced parameters are further protected by an Advanced Password.

This password will be provided, when necessary, by Factory technical support.

Factory Password

Calibration-related and other factory settings are further protected by a Factory Password.

2.6.4 Model R86 Menu: Step-By-Step Procedure

NOTE: Context-sensitive HELP is available for all menu and parameter items. With the item highlighted, hold down the **ENTER** key for two seconds. Use **UP** and **DOWN** for navigation.

The tables in Section 2.6.5 provide a complete explanation of the software menus displayed by the PULSAR Model R86 transmitter. The menu layout is similar between the local Keypad/LCD interface, the DD, and the DTM.

Use these tables as a step-by-step guide to configure the transmitter based on the desired measurement type from the following selections:

- Level Only
- Volume & Level
- Flow

HOME SCREEN

The Home Screen consists of a “slide show” sequence of Measured Values screens which are rotated at 2-second intervals. Each Home Measured Value screen can present up to four information items:

- HART® Tag
- Measured Value
Label, Numerical Value, Units
- Status
Will be displayed as text or optionally with NAMUR NE 107 symbol
- Primary Value Bar Graph (shown in %)

The Home Screen presentation can be customized by viewing or hiding some of these items. See DISPLAY CONFIG under the DEVICE SETUP menu in Section 2.6.5, *Configuration Menu*.

At left is an example of a Home Screen for a Model R86 configured for a Level Only application.





MAIN MENU

Pressing any key on the Home Screen will present the Main Menu, consisting of three basic menu labels shown in all capital letters.

- **DEVICE SETUP**
- **DIAGNOSTICS**
- **MEASURED VALUES**
- **WIZARDS**

As shown, the reverse video represents a cursor identifying the selected item, which will appear in reverse video on the LCD. The actions of the keys at this point are:

Push button		Keystroke Action
	Up	No action as the cursor is already at the first item in the MAIN MENU
	Down	Moves the cursor to DIAGNOSTICS
	Back	Moves back to HOME SCREEN, the level above MAIN MENU
	Enter	Presents the selected item, DEVICE SETUP

NOTES: 1. Items and parameters that are shown in lower level menus will depend on the Measurement Type chosen. Those parameter not applicable to the present Measurement Type will be hidden.

2. Holding down the Enter key when the cursor is highlighted over a parameter or menu will provide additional information about that item.



DEVICE SETUP

Choosing DEVICE SETUP from the MAIN MENU will result in an LCD presentation as shown at left.

The small down arrow shown at the right hand side of the screen is the indication that more items are available below and can be accessed by pressing the DOWN key.

Section 2.6.5 shows the entire tree menu for the Model R86 DEVICE SETUP Menu.

DIAGNOSTICS

Refer to Section 3.4

MEASURED VALUES

Allows the user to scroll through all of the available measured values for the measurement type chosen.

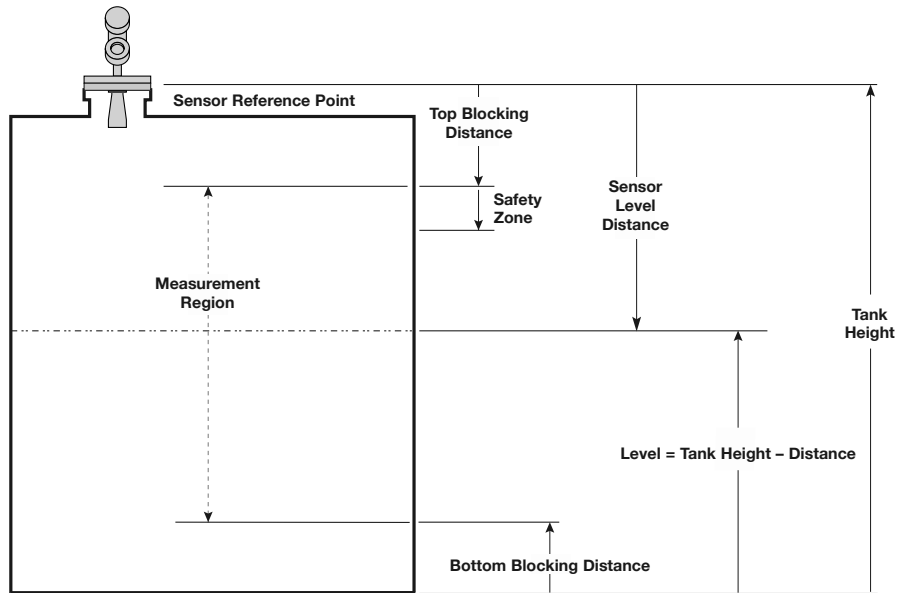

R86 Level Model

2.6.5 Model R86 Configuration Menu – Device Setup

NOTE: Context-sensitive HELP is available for all menu items. With the menu item highlighted, hold down the **⇨ ENTER** key for two seconds. Use **⇧ UP** and **⇩ DOWN** for navigation.

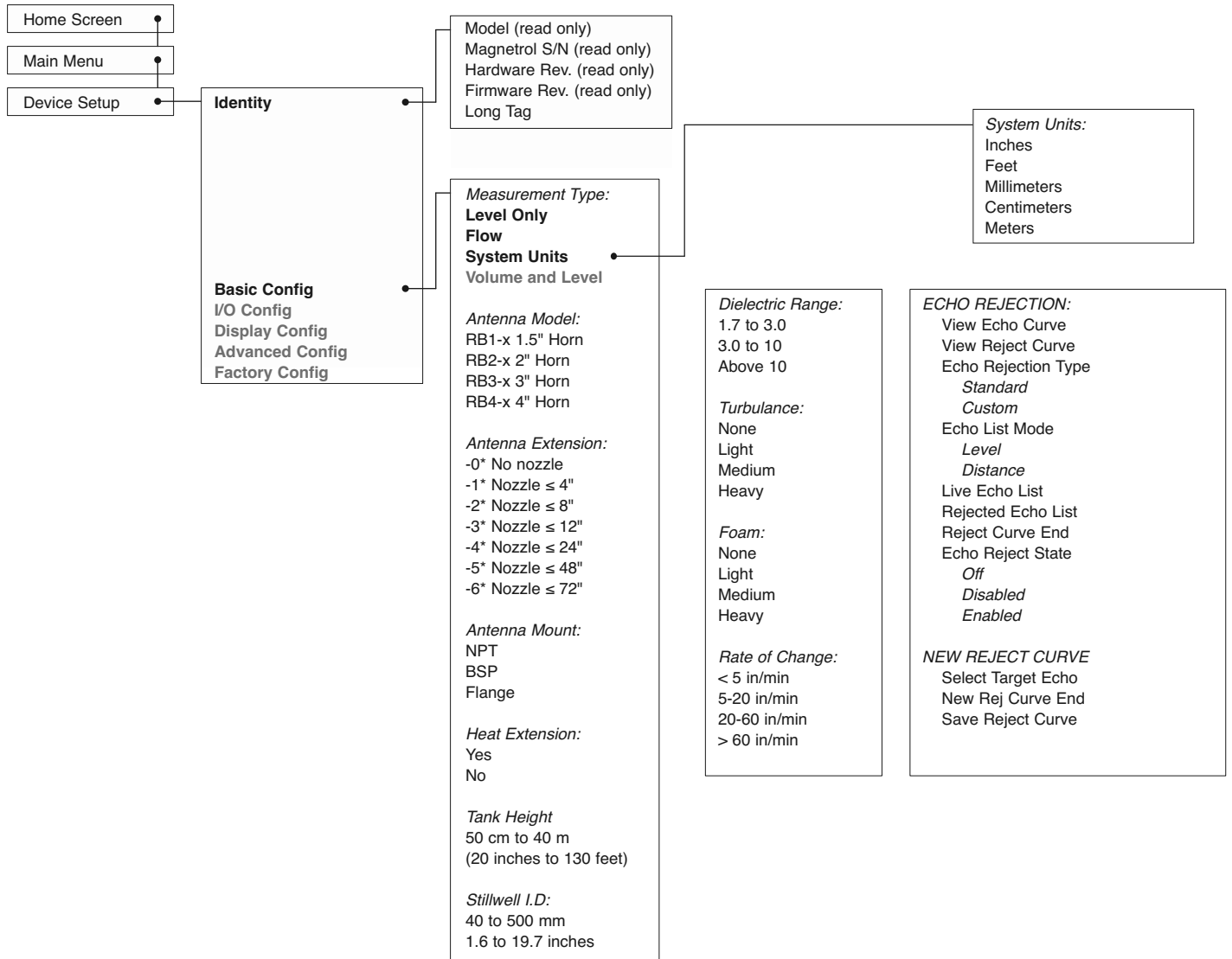

2.6.5 Model R86 Configuration Menu – Device Setup

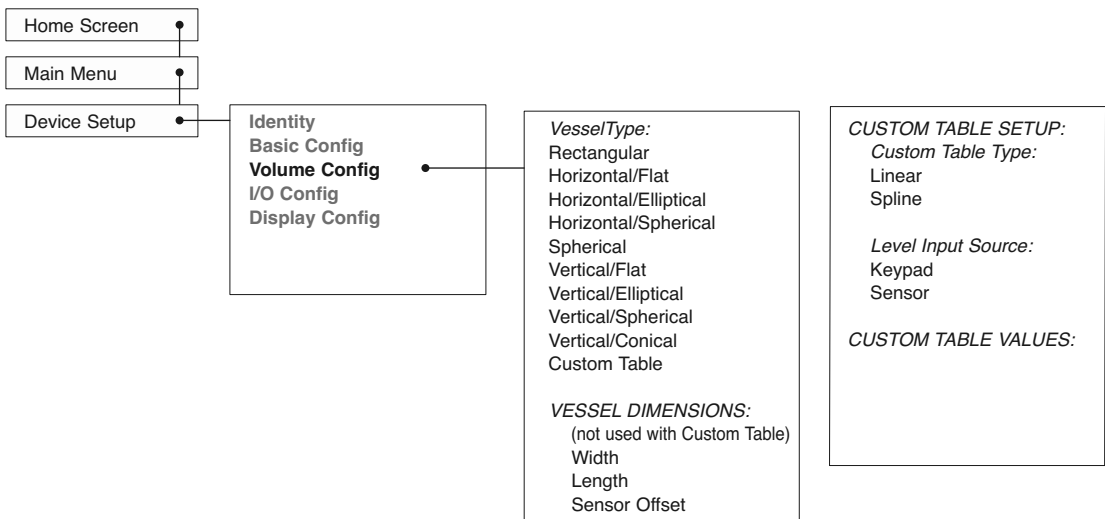
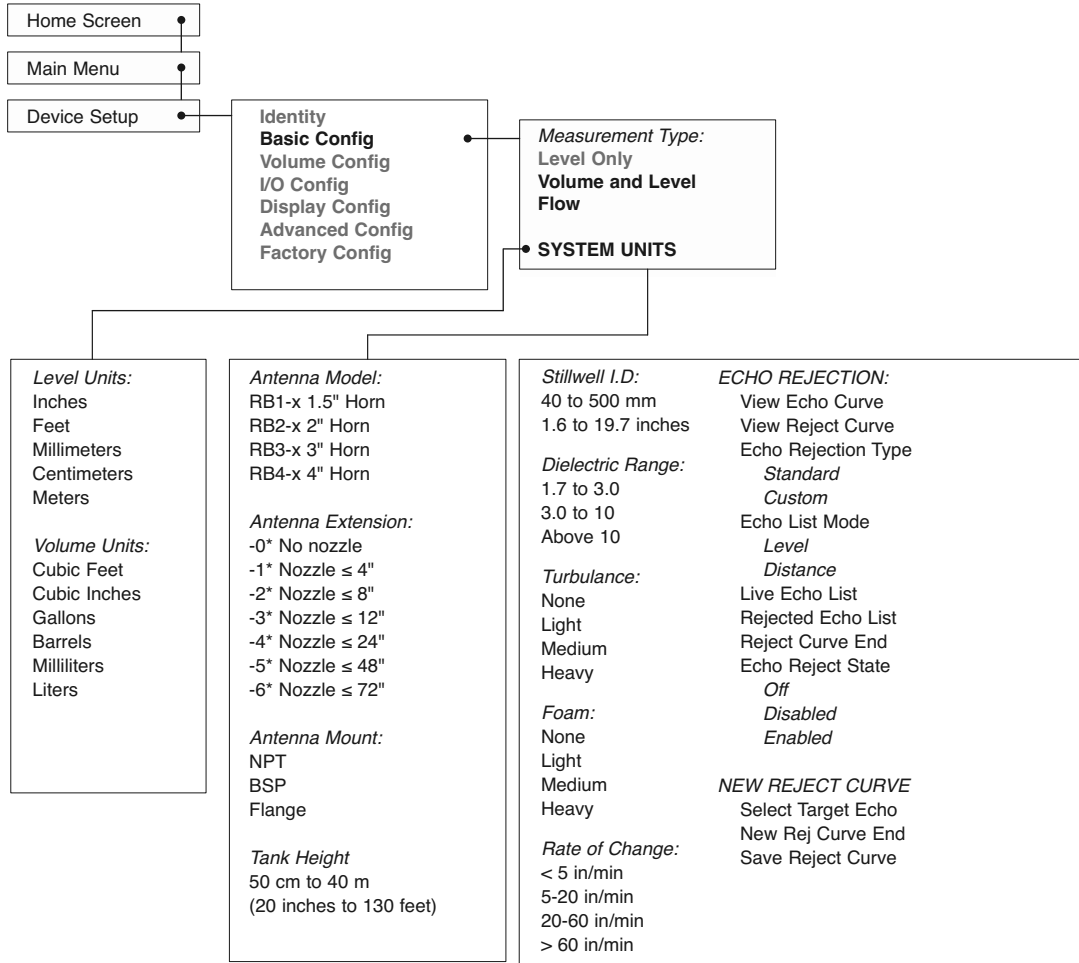

2.6.5 Model R86 Configuration Menu – Device Setup

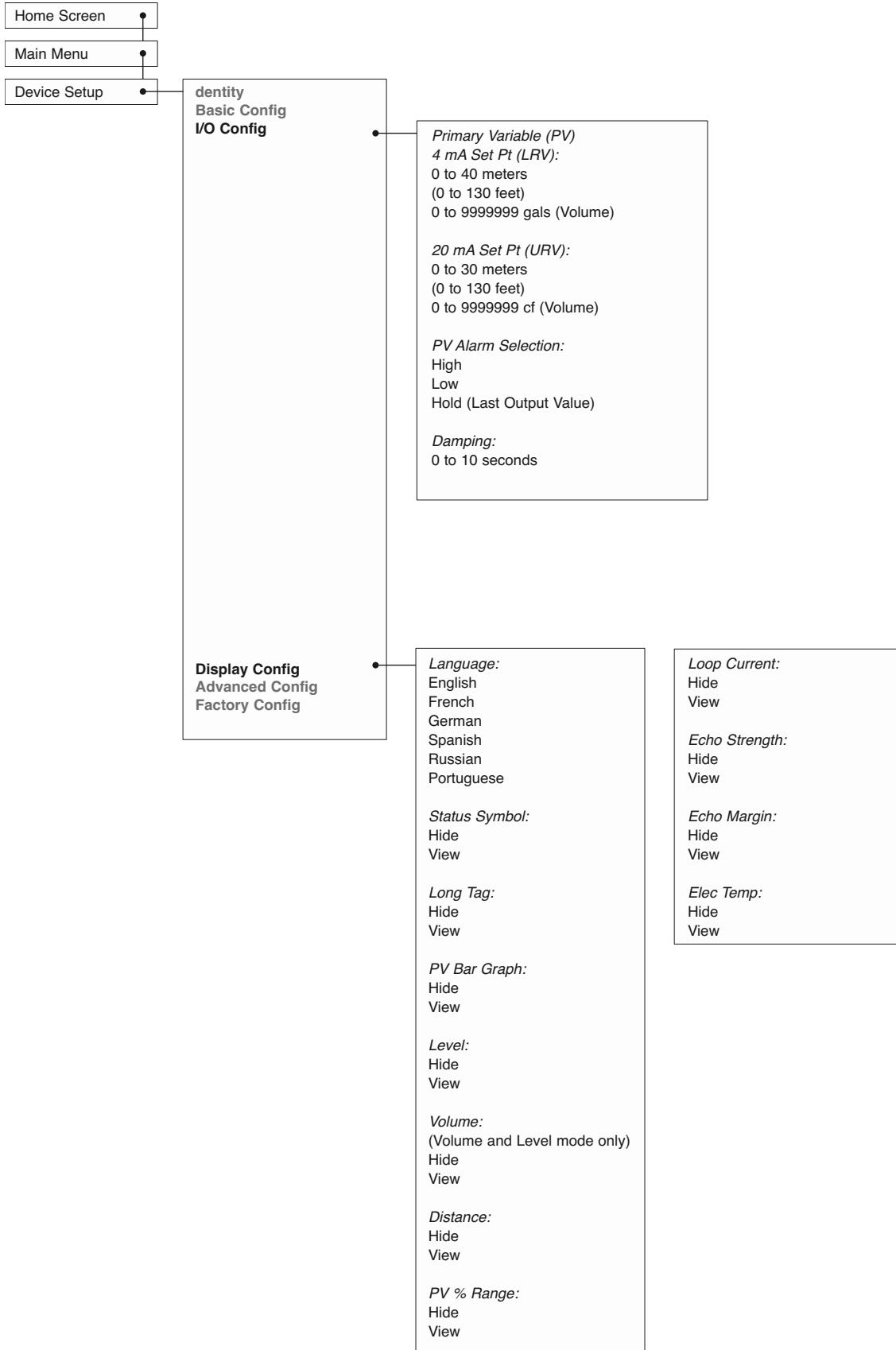

2.6.5 Model R86 Configuration Menu – Device Setup

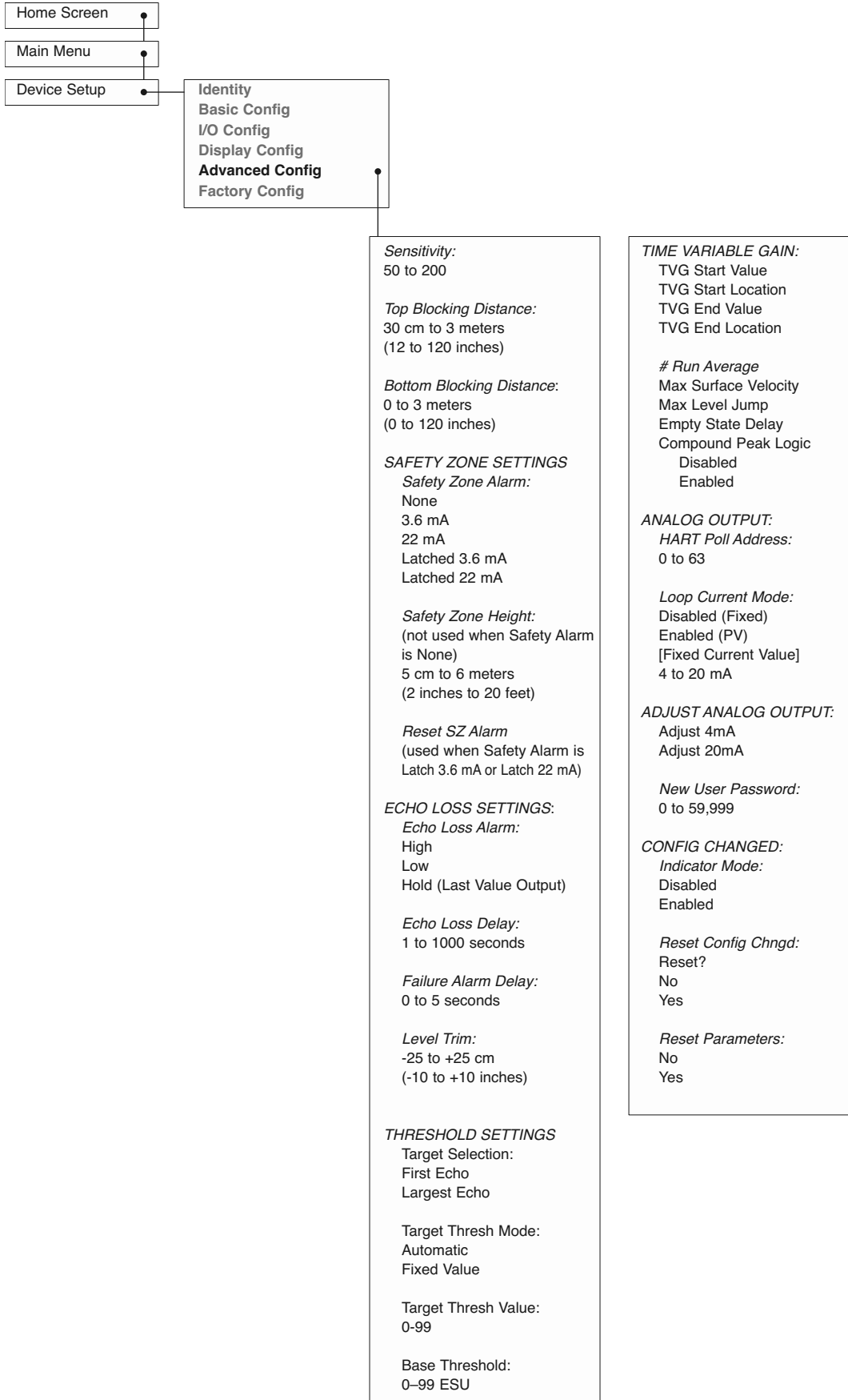

2.6.5 Model R86 Configuration Menu – Device Setup

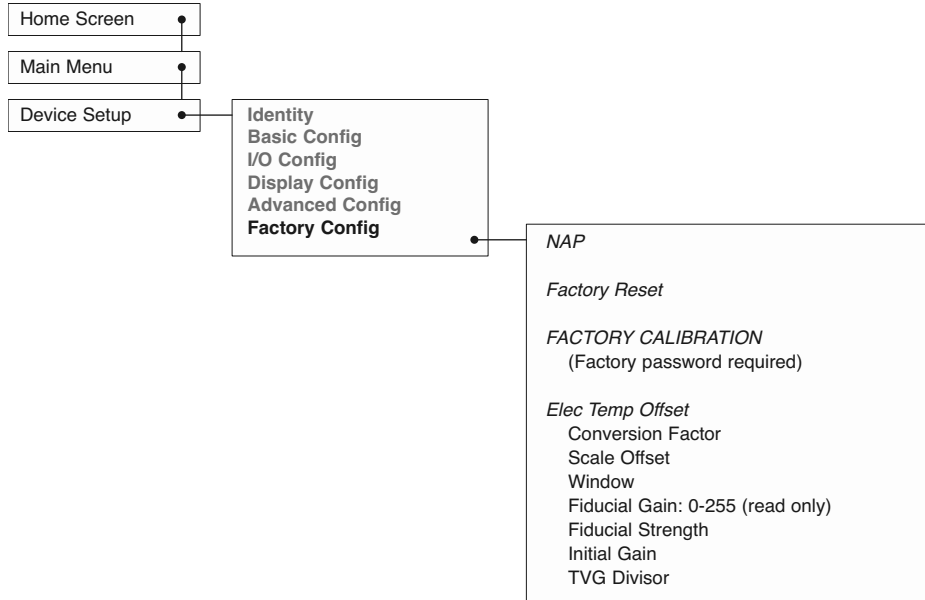

2.7 Configuration Using HART®

A HART (Highway Addressable Remote Transducer) remote unit, such as a HART communicator, can be used to provide a communication link to the PULSAR Model R86 transmitter. When connected to the control loop, the same system measurement readings shown on the transmitter are also shown on the communicator. The communicator can also be used to configure the transmitter.

The HART communicator may need to be updated to include the PULSAR Model R86 software (Device Descriptions). Refer to your HART Communicator Manual for update instructions.

One can also access configuration parameters using PACTware and the Model R86 DTM, or using the AMS with EDDL.

2.7.1 Connections

A HART communicator can be operated from a remote location by connecting it to a remote junction or by connecting it directly to the terminal block in the electronics housing of the PULSAR Model R86 transmitter.

HART uses the Bell 202 frequency shift key technique of high-frequency digital signals. It operates on the 4–20 mA loop and requires 250 Ω load resistance. A typical connection between a communicator and the PULSAR Model R86 transmitter is illustrated.

2.7.2 Display Menu

A typical communicator display is an 8-line by 21-character LCD. When connected, the top line of each menu displays the model (Model R86) and its tag number or address. For detailed operating information, refer to the instruction manual provided with the HART communicator.

The PULSAR Model R86 transmitter online menu trees are shown in the following illustration. Open the menu by pressing the alphanumeric key 4, Device Setup, to display the second-level menu.

2.7.3 HART Revision Table

2.7.3.1 Model R86

HART Version	HCF Release Date	Compatible with R86 Software
Dev V1 DD1	April 2017	Version 1.0a and later

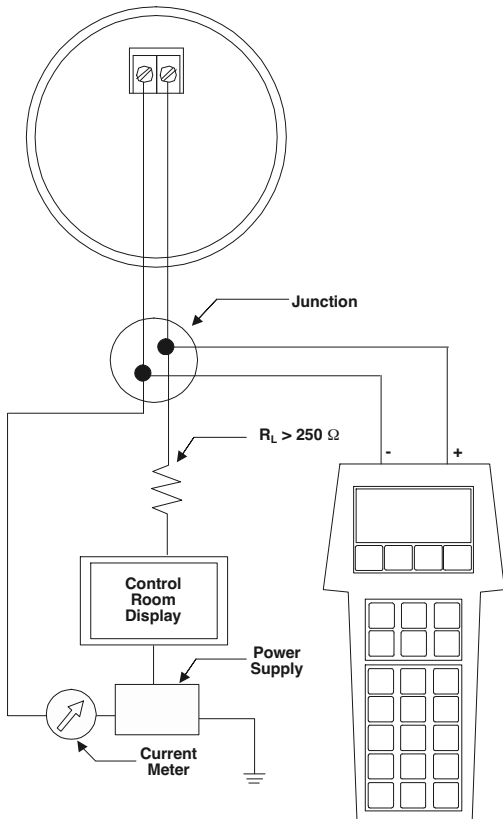

2.7.4 HART Menu

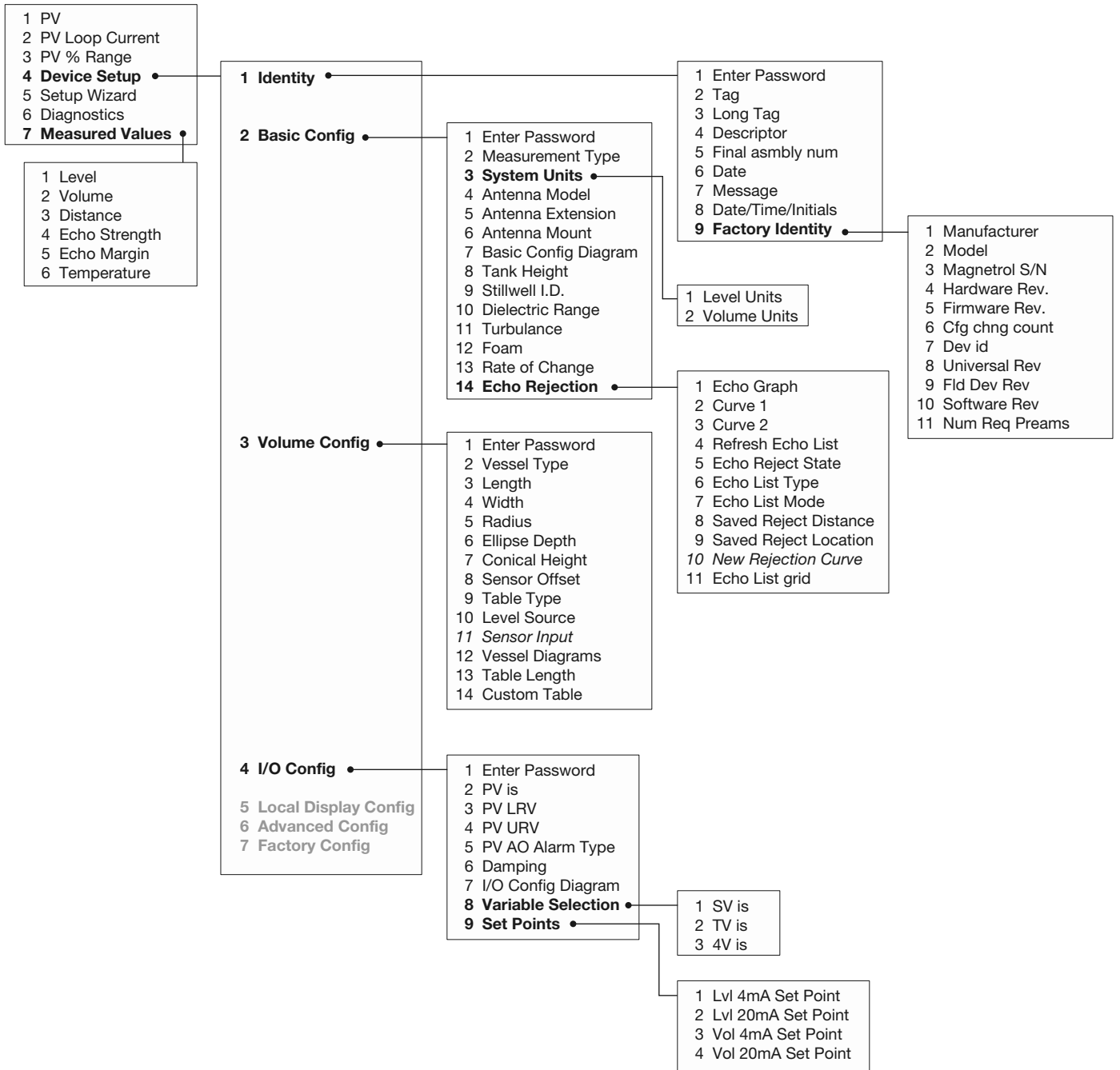

2.7.4 HART Menu (continued)

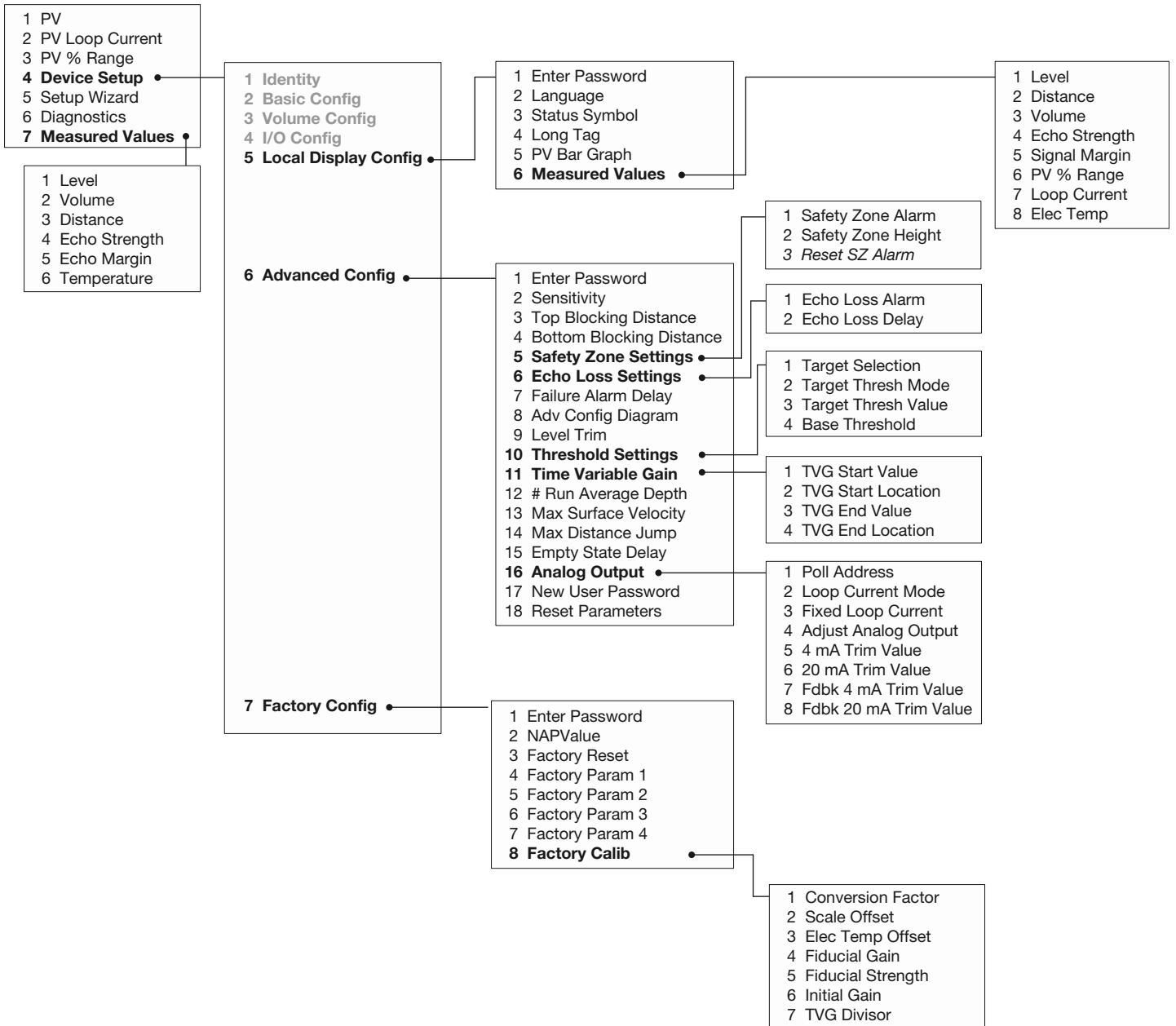

3.0 Reference Information

This section presents an overview of the operation of the PULSAR Model R86 Radar Level Transmitter, information on troubleshooting, common problems, listings of agency approvals, lists of replacement and recommended spare parts, and detailed physical, functional and performance specifications.

3.1 Description

The PULSAR Model R86 is a two-wire, 24 VDC, level transmitter based on the concept of pulse burst radar. The electronics are housed in an ergonomic housing comprised of two tandem compartments angled at a 20-degree angle for ease of wiring and calibration. These two compartments connect via a watertight feed-through.

3.2 Theory of Operation

3.2.1 Pulse Burst Radar

PULSAR Model R86 is a top-mounted, downward-looking pulse burst radar operating at 26 GHz. Unlike true pulse devices (GWR, for example) that transmit a single, sharp (fast rise-time) waveform of wide-band energy, PULSAR Model R86 emits short bursts of 26 GHz energy and measures the transit time of the signal reflected off the liquid surface. Distance is calculated utilizing the equation: $\text{Distance} = C (\text{Speed of light}) \times \text{Transit time} / 2$, then developing the Level value by factoring in application-specific configuration. The exact reference point for distance and level calculations is the Sensor Reference Point—bottom of an NPT thread, top of a BSP thread or face of a flange.

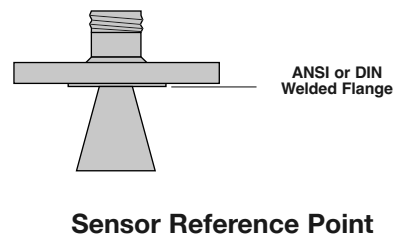
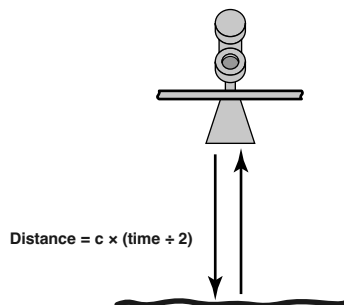
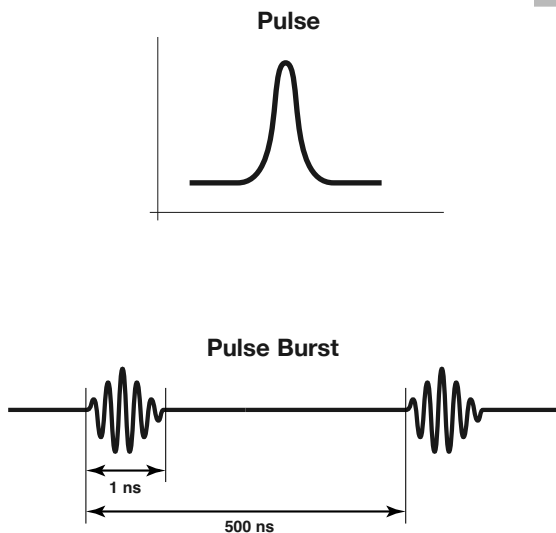

The exact level measurement is extracted from false target reflections and other background noise via the use of sophisticated signal processing. The new PULSAR Model R86 circuitry is extremely energy efficient so no duty cycling is necessary to accomplish effective measurement.

3.2.2 Equivalent Time Sampling

ETS, or Equivalent Time Sampling, is used to measure the high speed, low power EM (electromagnetic) energy. ETS is a critical key in the application of Radar to vessel level measurement technology. The high speed electromagnetic energy (1000 ft/ μ s) is difficult to measure over short distances and at the resolution required in the process industry. ETS captures the EM signals in real time (nanoseconds) and reconstructs them in equivalent time (milliseconds), which is much easier to measure with today's technology.

ETS is accomplished by scanning the tank to collect thousands of samples. Approximately three scans are taken per second; each scan gathers more than 14,000 samples.

3.3 Configuration Information

This section is intended to offer additional configuration-related details with respect to some of the parameters shown in the Menu in Section 2.6.

3.3.1 Bottom Blocking Distance Description

The parameter referred to as Bottom Blocking Distance in the PULSAR Model R86 DEVICE SETUP/ADVANCED CONFIG menu is defined as the distance from the bottom of the tank to the lowest valid level reading.

NOTE: The level reading will never be lower than the Bottom Blocking Distance or higher than the Top Blocking Distance.

The PULSAR Model R86 transmitter is shipped from the factory with Bottom Blocking Distance set to 0. With this configuration, level measurements are referenced from the bottom of the tank. See Example 1.

Example 1 (Bottom Blocking Distance = 0 as shipped from factory):

Application calls for a Model RB2 antenna in an 200 cm tank with a flanged process connection. The process medium is water.

The user wants the 4 mA Set Point (LRV) at 60 cm and the 20 mA Set Point (URV) at 150 cm as **referenced from the bottom of the tank.**

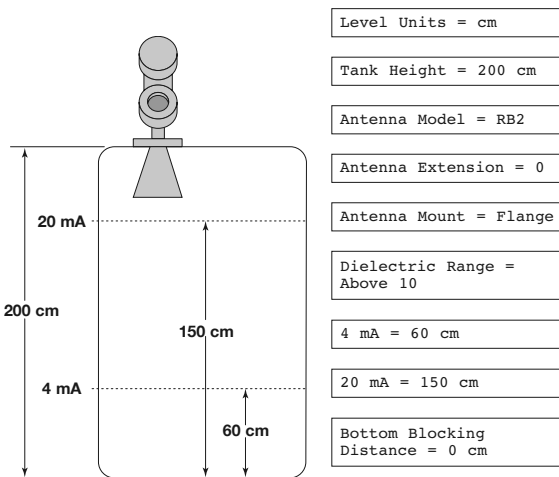

Example 1

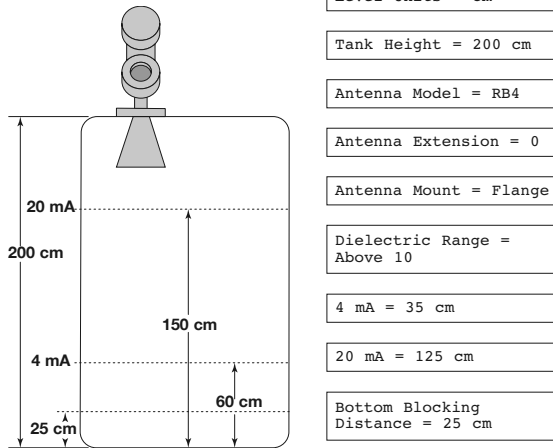

Example 2

Example 2 (Bottom Blocking Distance = 25 cm):

Application calls for a Model RB4 antenna in an 200 cm tank with a flanged process connection.

The user wants the 4 mA Set Point (LRV) at 60 cm and the 20 mA Set Point (URV) at 150 cm as **referenced from the bottom of the tank.**

When the PULSAR Model R86 transmitter is mounted in a stillwell, it is usually desirable to configure the unit with the 4 mA Set Point (LRV) at the lower process connection and the 20 mA Set Point (URV) at the upper process connection. The measuring range then becomes the center-to-center dimension.

Example 3:

Application calls for a Model RB3 flanged antenna measuring water in a chamber with ID = 8 cm. The user wants the 4 mA point at the bottom process connection and the 20 mA point at the top process connection.

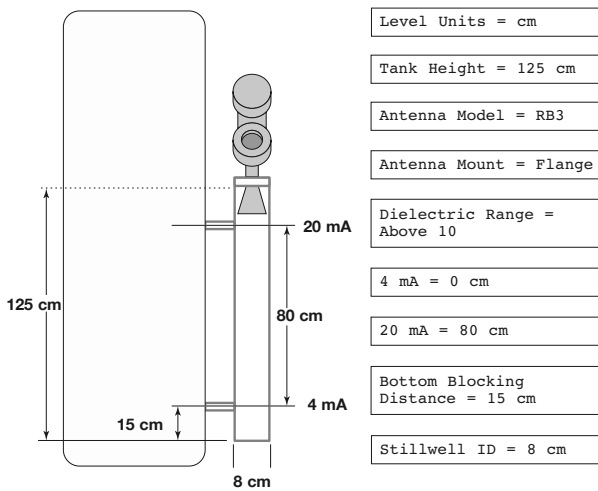

Example 3

3.3.2 Reset Function

A parameter labeled “Reset Parameter” is located at the end of the DEVICE SETUP/ADVANCED CONFIG menu. In the event a user gets confused during configuration or advanced troubleshooting, this parameter gives the user the ability to reset the Model R86 transmitter configuration.

Unique to the Model R86 transmitter is the ability for MAGNETROL to fully “pre-configure” devices to customer requests. For that reason, the Reset function will return the device back to the state **at which it left the factory.**

It is recommended that MAGNETROL Technical Support be contacted as the Advanced User password will be required for this reset.

3.3.3 Echo Rejection

Since all Non-Contact radar transmitters are application/installation dependent, Echo Rejection (ignoring false targets) may be necessary.

The Model R86 transmitter Echo Rejection feature is located in the DEVICE SETUP/BASIC CONFIG menu, and requires the User Password to activate. It is highly recommended that this feature be used with the waveform capture capability of the Model R86 DTM and PACT^{ware}™.

Refer to Section 4.0, *Advanced Configuration/Troubleshooting Techniques* or contact MAGNETROL Technical Support for additional instructions.

3.3.4 Volumetric Capability

Selecting Measurement Type = Volume and Level allows the Model R86 transmitter to measure volume as the Primary Measured Value.

3.3.4.1 Configuration using built-in Vessel Types

The following table provides an explanation of each of the System Configuration parameters required for volume applications that use one of the nine Vessel Types.

MEASUREMENT TYPE = LEVEL & VOLUME

Configuration Parameter	Explanation
System Units	A selection of Gallons, Barrels, Milliliters, Liters, Cubic Feet, or Cubic Inches, is provided. (Factory default is Cubic Feet)
Vessel Type	Select either Vertical/Flat (factory default Vessel Type), Vertical/Elliptical, Vertical/Spherical, Vertical/Conical, Rectangular, Horizontal/Flat, Horizontal/Elliptical, Horizontal/Spherical, Spherical, or Custom Table. Note: Vessel Dims is the next screen only if a specific Vessel Type was selected. If Custom Table was selected. Refer to page 44 to select the Cust Table Type and Cust Table Vals.
Vessel Dims	See the vessel drawings on the following page for relevant measuring areas.
Radius	Used for all Vessel Types with the exception of Rectangular.
Ellipse Depth	Used for Horizontal and Vertical/Elliptical vessels.
Conical Height	Used for Vertical/Conical vessels.
Width	Used for Rectangular vessels.
Length	Used for Rectangular and Horizontal vessels.

Vessel Types

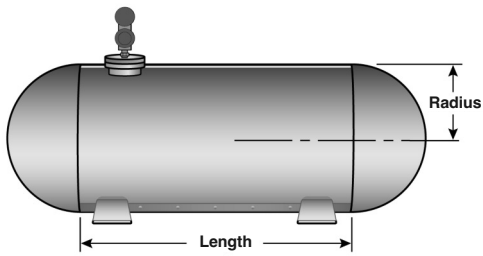

HORIZONTAL/SPHERICAL

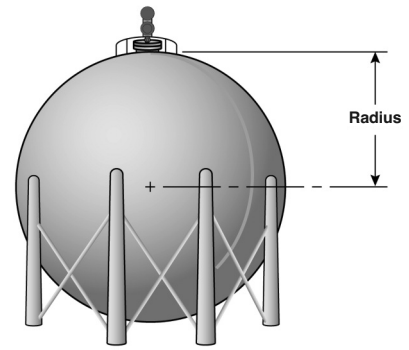

SPHERICAL

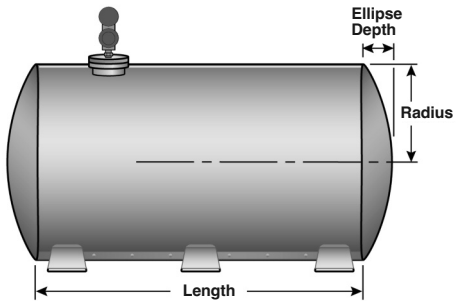

HORIZONTAL/ELLIPTICAL

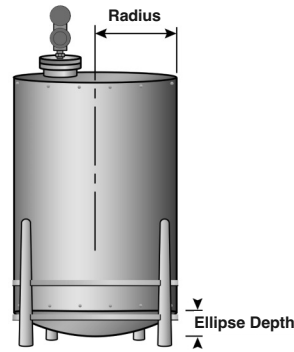

VERTICAL/ELLIPTICAL

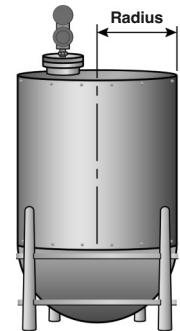

VERTICAL/SPHERICAL

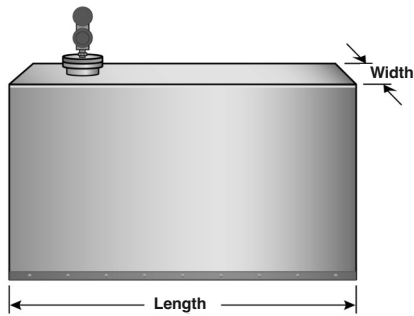

RECTANGULAR

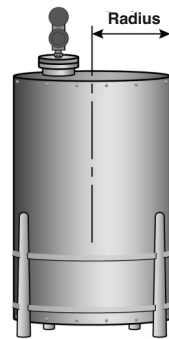

VERTICAL/FLAT

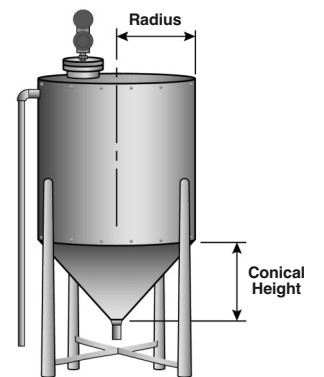

VERTICAL/CONICAL

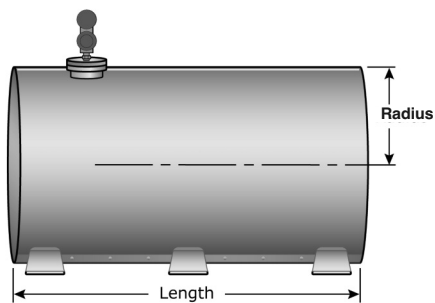

HORIZONTAL/FLAT

3.3.4.2 Configuration using Custom Table

If none of the nine *Vessel Types* shown can be used, a *Custom Table* can be created. A maximum of 30 points can be used to establish the level to volume relationship. The following table provides an explanation of each of the System Configuration parameters for volume applications where a Custom Table is needed.

Configuration Parameter	Explanation (Custom Volumetric Table)
Volume Units	A selection of Gallons, Barrels, Milliliters, Liters, Cubic Feet, or Cubic Inches , is provided.
Vessel Type	Select Custom Table if none of the nine <i>Vessel Types</i> can be used.
Cust Table Type	The <i>Custom Table</i> points can be a Linear (straight line between adjacent points) or Spline (can be a curved line between points) relationship. See drawing below for more information.
Cust Table Vals	A maximum of 30 points can be used in building the <i>Custom Table</i> . Each pair of values will have a level (height) in the units chosen in the <i>Level Units</i> screen, and the associated volume for that level point. The values must be monotonic, i.e., each pair of values must be greater than the previous level/volume pair. The last pair of values should have the highest level value and volume value associated with the level in the vessel.

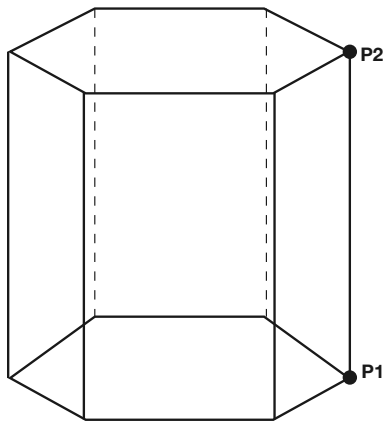

LINEAR

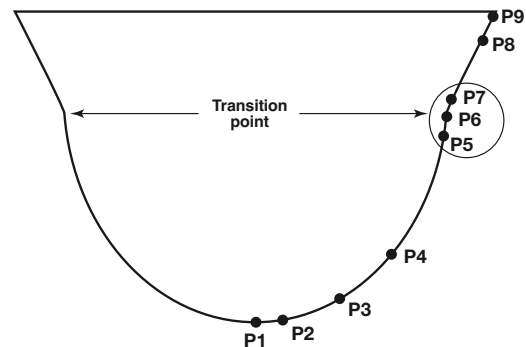

Use where walls are not perpendicular to base.

Concentrate at least two points at beginning (P1) and end (P9); and three points at either side of transition points.

SPLINE

3.3.5 Open Channel Flow Capability

Selecting Measurement Type = Flow allows the PULSAR Model R86 transmitter to measure flow as the Primary Measured Value.

Open channel flow is performed by using the Model R86 to measure the Head in a hydraulic structure. The hydraulic structure is the primary measuring element, of which the two most common types are weirs and flumes.

Since the primary element has a defined shape and dimensions, the rate of flow through the flume or over the weir is related to the Head at a specified measurement location.

The Model R86 is the secondary measuring device, which measures the Head of the liquid in the flume or weir. Open channel flow equations stored in the transmitter firmware convert the measured Head into units of flow (volume/time).

NOTE: Proper positioning of the Model R86 should be per the recommendation of the flume or weir manufacturer.

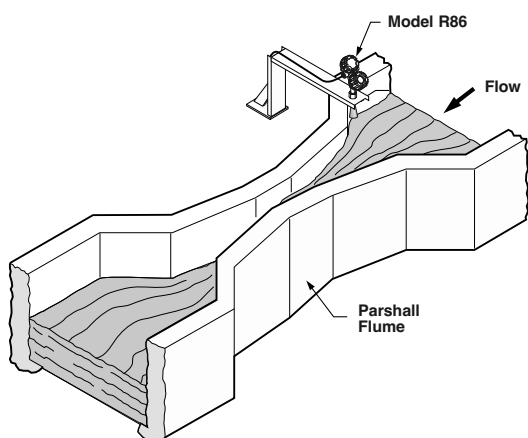

Open Channel Flow Measurement
Parshall Flume

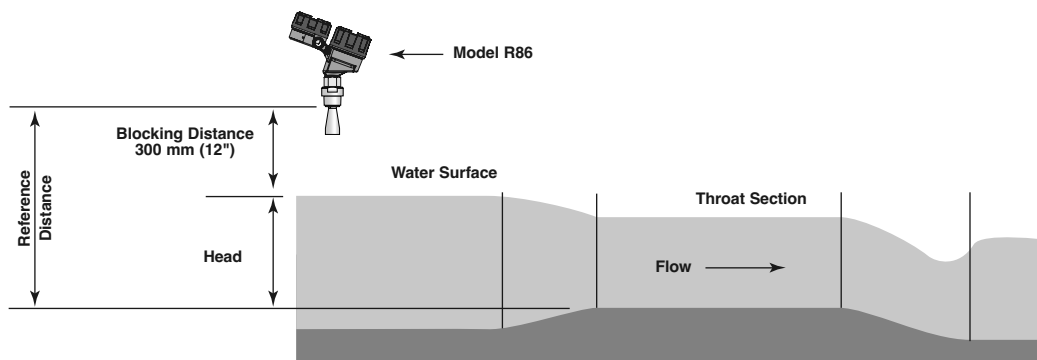

Flume (side view)

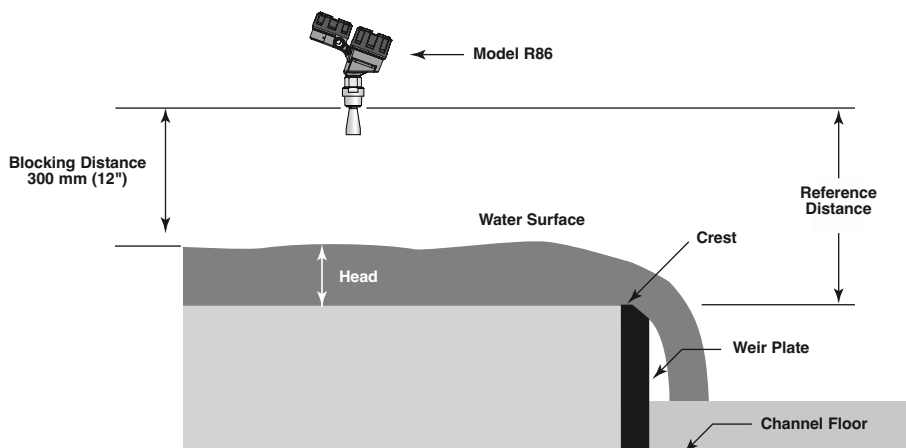

Weir (side view)

3.3.5.1 Configuration using Flume/Weir Equations

The following table provides an explanation of each of the System Configuration parameters required for open channel flow applications using one of the Flow Elements that are stored in the firmware.

Configuration Parameter	Explanation
Flow Units	A selection of Gallons/Minute (factory default <i>Flow Unit</i>), Gallons/Hour , Mil Gallons/Day , Liters/Second , Liters/Minute , Liters/Hour , Cubic Meter/Hour , Cubic Ft/Second , Cubic Ft/Minute , and Cubic Ft/Hour are provided.
Flow Element	Select one of the following primary <i>Flow Elements</i> that are stored in the firmware: Parshall flume sizes of 1", 2", 3", 6", 9", 12", 18", 24", 36", 48", 60", 72", 96", 120" and 144" . Palmer-Bwls (Palmer-Bowlus) flume sizes of 4", 6", 8", 10", 12", 15", 18", 21", 24", 27" and 30" . V-notch weir sizes of 22.5°, 30°, 45°, 60°, 90° and 120° . Rect with Ends (Rectangular Weir with End Contractions), Rect w/o Ends (Rectangular Weir without End Contractions), and Cipoletti weir. Custom Table (see page 44) can be selected if none of the stored <i>Flow Elements</i> can be used. The table can be built with a maximum of 30 points. The Model R86 also has the capability of using a Generic Equation (see page 43) for flow calculation.
Weir Crest Length	The <i>Weir Crest Length</i> screen only appears when the chosen <i>Flow Element</i> is Cipoletti or one of the <i>Rectangular</i> weirs. Input this length in the user-selected level units.
Flume Channel Width	Allows for entry of the width of the Palmer-Bowlus flume.
V-Notch Weir Angle	Only appears when flow element is V-Notch weir. It allows for the entry of angle of the V-Notch weir.
Reference Dist	The <i>Reference Distance</i> is measured from the sensor reference point to the point of zero flow in the weir or flume. This must be measured very accurately in the user-selected level units.
Maximum Head	<i>Maximum Head</i> is the highest liquid level (Head) value in the flume or weir before the flow equation is no longer valid. The <i>Maximum Head</i> is expressed in the user-selected <i>Level Units</i> . The Model R86 will default to the largest <i>Maximum Head</i> value that is allowed for any given flume or weir. The <i>Maximum Head</i> value can be revised depending on the value of the <i>Reference Distance</i> , or for end user preference.
Maximum Flow	<i>Maximum Flow</i> is a read-only value that represents the flow value corresponding to the <i>Maximum Head</i> value for the flume or weir.
Low Flow Cutoff	The <i>Low Flow Cutoff</i> (in user-selected level units) will force the calculated flow value to zero whenever the <i>Head</i> is below this point. This parameter will have a default and minimum value of zero.

3.3.5.2 Configuration using Generic Equation

The following table provides an explanation of each of the System Configuration parameters for Open channel flow applications using the Generic Equation.

Configuration Parameter	Explanation (Open Channel Flow – using the Generic Equation)
Flow Units	A selection of Gallons/Minute (factory default <i>Flow Unit</i>), Gallons/Hour, Mil Gallons/Day, Liters/Second, Liters/Minute, Liters/Hour, Cubic Meter/Hour, Cubic Ft/Second, Cubic Ft/Minute, and Cubic Ft/Hour are provided.
Flow Element	Select one of the following primary <i>Flow Elements</i> that are stored in the firmware: Parshall flume sizes of 1", 2", 3", 6", 9", 12", 18", 24", 36", 48", 60", 72", 96", 120" and 144". Palmer-Bowlus flume sizes of 4", 6", 8", 10", 12", 15", 18", 21", 24", 27" and 30". V-notch weir sizes of 22.5°, 30°, 45°, 60°, 90° and 120°. Rect with Ends (Rectangular Weir with End Contractions), Rect w/o Ends (Rectangular Weir without End Contractions), and Cipoletti weir. Custom Table (see page 44) can be selected if none of the stored <i>Flow Elements</i> can be used. The table can be built with a maximum of 30 points. The Model R86 also has the capability of using a Generic Equation (see below) for flow calculation.
Generic Eqn Factors	<i>Generic Equation</i> is a discharge flow equation in the form of $Q = K(L-CH)H^n$, where Q = flow (Cu Ft/Second), H = Head (Feet), K = a constant, and L, C and n are user input factors that depend on which <i>Flow Element</i> is being used. Make sure the flow equation is in the form of $Q = K(L-CH)H^n$, and proceed to enter the values of K,L,C,H and n. See example below. NOTE: The Generic Equation parameters must be entered in Cu Ft/Second units . The resultant flow is converted by the Model R86 into whatever Flow Units are selected above. See example below.
Reference Dist	The <i>Reference Distance</i> is measured from the sensor reference point to the point of zero flow in the weir or flume. This must be measured very accurately in the user-selected level units.
Maximum Head	<i>Maximum Head</i> is the highest liquid level (Head) value in the flume or weir before the flow equation is no longer valid. The <i>Maximum Head</i> is expressed in the user-selected level units. The Model R86 will default to the largest <i>Maximum Head</i> value that is allowed for any given flume or weir. The <i>Maximum Head</i> value can be revised depending on the value of the <i>Reference Distance</i> , or for end user preference.
Maximum Flow	<i>Maximum Flow</i> is a read-only value that represents the flow value corresponding to the <i>Maximum Head</i> value for the flume or weir.
Low Flow Cutoff	The <i>Low Flow Cutoff</i> (in user-selected level units) will force the calculated flow value to zero whenever the <i>Head</i> is below this point. This parameter will have a default and minimum value of zero.

Generic Equation Example (using equation for an 8' rectangular weir w/ end contractions)		
Q = Cubic Ft/Second flow rate	L = 8' (weir crest length in feet)	H = Head value
K = 3.33 for Cubic Ft/Second units	C = 0.2 (constant)	n = 1.5 as an exponent

Using the factors above the equation becomes:

$$Q = 3.33 (8-0.2H) H^{1.5}$$

$$Q = K(L-CH)H^n$$

The discharge flow value for a Head value of three feet becomes 128.04 **Cubic Ft/Second**. If GPM was selected for the Flow Units, the Model R86 Measured Values screen would display this value converted to 57,490 GPM.

3.3.5.3 Configuration using Custom Table

Concentrate points as follows:

- A. At least two points at beginning (P1 and P2);
- B. At least two points at end (P9 and P10);
- C. Three points at approximate average flow rate (for example, P3, P4, P5); and at transition point (P7) and points on either side (P6,P8)

The following table provides an explanation of each of the System Configuration parameters for open channel flow applications using the Custom Table.

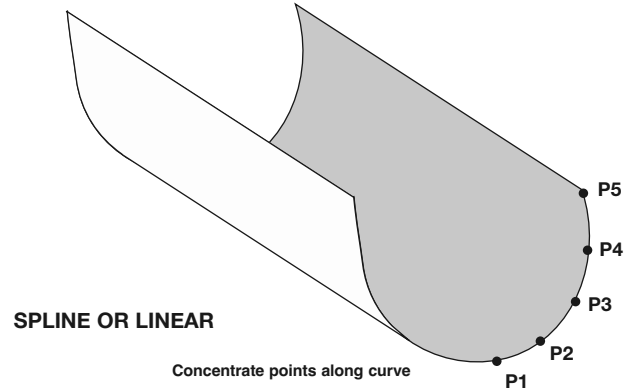
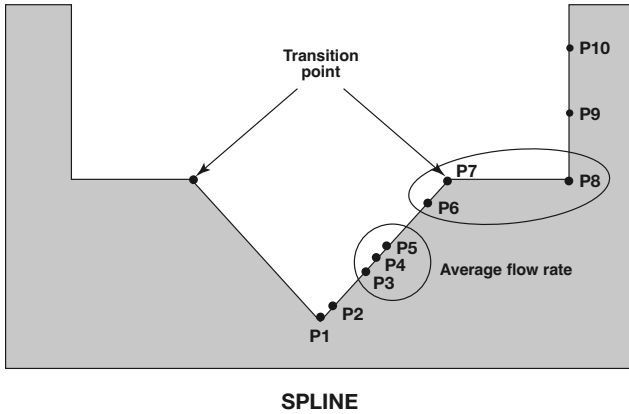

Configuration Parameter	Explanation (Open Channel Flow – Custom Table)
Flow Units	A selection of Gallons/Minute (factory default <i>Flow Unit</i>), Gallons/Hour, Mil Gallons/Day, Liters/Second, Liters/Minute, Liters/Hour, Cubic Meters/Hour, Cubic Ft/Second, Cubic Ft/Minute, and Cubic Ft/Hour are provided.
Flow Element	Select one of the following primary <i>Flow Elements</i> that are stored in the firmware: Parshall flume sizes of 1", 2", 3", 6", 9", 12", 18", 24", 36", 48", 60", 72", 96", 120" and 144". Palmer-Bowlus flume sizes of 4", 6", 8", 10", 12", 15", 18", 21", 24", 27" and 30". V-notch weir sizes of 22.5°, 30°, 45°, 60°, 90° and 120°. Rect with Ends (Rectangular Weir with End Contractions), Rect w/o Ends (Rectangular Weir without End Contractions), and Cipoletti weir. Custom Table (see below) can be selected if none of the stored <i>Flow Elements</i> can be used. The table can be built with a maximum of 30 points. The Model R86 also has the capability of using a Generic Equation (see page 43) for flow calculation.
Custom Table	The <i>Custom Table</i> points can be a Linear (straight line between adjacent points) or Spline (can be a curved line between points) relationship. Refer to the drawing above for more information.
Cust Table Vals	A maximum of 30 points can be used in building the <i>Custom Table</i> . Each pair of values will have a Head (height) in the units chosen in the <i>Level Units</i> screen, and the associated flow for that Head value. The values must be monotonic, i.e., each pair of values must be greater than the previous Head/flow pair. The last pair of values should have the highest Head value (usually the <i>Maximum Head</i> value) and the flow associated with that Head value.
Reference Dist	The <i>Reference Distance</i> is measured from the sensor reference point to the point of zero flow in the weir or flume. This must be measured very accurately in the user-selected level units.
Maximum Head	<i>Maximum Head</i> is the highest liquid level (Head) value in the flume or weir before the flow equation is no longer valid. The <i>Maximum Head</i> is expressed in the user-selected <i>Level Units</i> . The Model R86 will default to the largest <i>Maximum Head</i> value that is allowed for any given flume or weir. The <i>Maximum Head</i> value can be revised depending on the value of the <i>Reference Distance</i> , or for end user preference.
Maximum Flow	<i>Maximum Flow</i> is a read-only value that represents the flow value corresponding to the <i>Maximum Head</i> value for the flume or weir.
Low Flow Cutoff	The <i>Low Flow Cutoff</i> (in user-selected level units) will force the calculated flow value to zero whenever the <i>Head</i> is below this point. This parameter will have a default and minimum value of zero.

3.4 Troubleshooting and Diagnostics

The PULSAR Model R86 transmitter is designed and engineered for trouble-free operation over a wide range of operating conditions. The transmitter continuously runs a series of internal self-tests and displays helpful messages on the large graphic liquid crystal display (LCD) when attention is required.

The combination of these internal tests and diagnostics messages offer a valuable proactive method of troubleshooting. The device not only tells the user what is wrong, but also, and more importantly, offers suggestions on how to solve the problem.

All of this information can be obtained directly from the transmitter on the LCD, or remotely by using a HART communicator or PACTware and the PULSAR Model R86 DTM.

PACTware™ PC Program

The PULSAR Model R86 offers the ability to perform more advanced diagnostics such as Trending and Echo Curve analysis using a DTM with PACTware. This is a powerful troubleshooting tool that can aid in the resolution of any diagnostic indicators that may appear.

Refer to Section 4.0, *Advanced Configuration/ Troubleshooting Techniques* for additional information.

3.4.1 Diagnostics (NAMUR NE 107)

The PULSAR Model R86 transmitter includes an exhaustive list of Diagnostic Indicators which follow the NAMUR NE 107 guidelines.

NAMUR is an international user association of automation technology in process industries, whose goal is to promote the interest of the process industry by pooling experiences among its member companies. In doing so, this group promotes international standards for devices, systems, and technologies.

The objective of NAMUR NE 107 was essentially to make maintenance more efficient by standardizing diagnostics information from field devices. This was initially integrated via FOUNDATION fieldbus, but the concept applies regardless of the communication protocol.

According to the NAMUR NE107 recommendation, "Self Monitoring and Diagnosis of Field Devices," fieldbus diagnostic results should be reliable and viewed in the context of a given application. The document recommends categorizing internal diagnostics into four standard status signals:

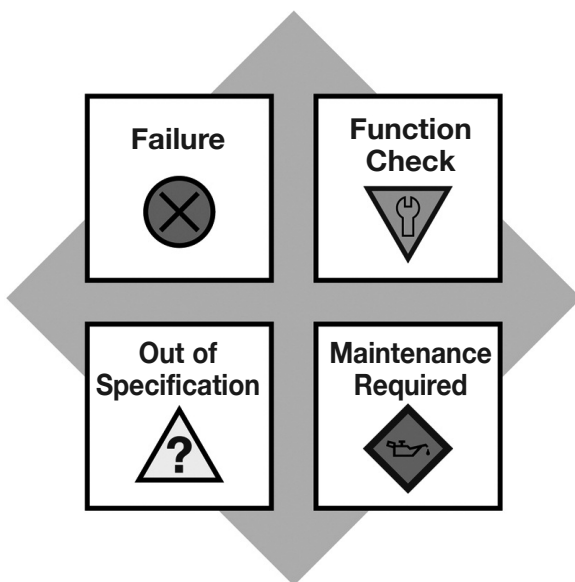

- Failure
- Function Check
- Out of Specification
- Maintenance required

These categories are shown by both symbols and colors, depending on the display capability.

In essence, this approach ensures that the correct diagnostic information is available to the correct person-at the correct time. In addition, it allows diagnostics to be applied, as most appropriate, for a particular plant application (such as process control engineering or asset management maintenance). Customer specific mapping of diagnostics to these categories allows for flexible configuration depending on the user's requirements.

From an external Model R86 transmitter perspective, diagnostic information includes measurement of process conditions, in addition to detection of internal device or system anomalies.

As mentioned above, the indicators can be assignable (via the a DTM or host system) by the user to any (or none) of the NAMUR recommended Status Signal categories: Failure, Function Check, Out of Specification, and Maintenance Required.

In the FOUNDATION fieldbus version of the transmitter, diagnostic indicators can be mapped to multiple categories (e.g., as shown in the diagram at left).

Indicators that are mapped to the Failure category will normally result in a current loop alarm output. The alarm state for HART transmitters is configurable as high (22 mA), Low (3.6 mA), or Hold (last value).

Users will not have the ability to unassign certain indicators from the Failure signal category as the Model R86 user interfaces will prohibit or reject such re-assignment entries. This is to ensure that current loop alarms are asserted in situations where the device is not able to provide measurements due to critical failures. (For example, if the alarm selection has not been set to Hold or a fixed current mode is in effect.)

A default mapping of all diagnostic indicators will be applied initially, and can be re-applied through use of a reset function.

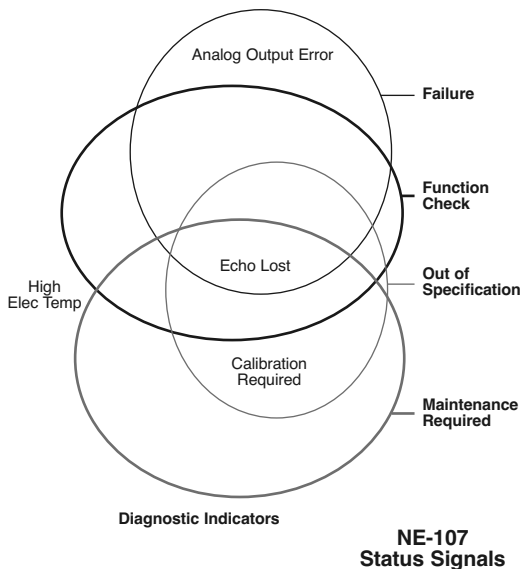

Refer to the Diagnostic Indicator tables in this section for a complete listing of the Model R86 diagnostic indicators, along with their explanations, default categories, and recommended remedies.

- NOTES:
- 1) The remedies shown in this table can also be seen on the transmitter LCD by viewing the present status screen when the device is in a diagnostic condition.
 - 2) Those indicators showing failure as the default result in an alarm condition.

3.4.2 Diagnostic Indication Simulation

The DD and DTM allow for the ability to manipulate diagnostic indicators. Intended as a means to verify the configuration of the diagnostic parameters and connected equipment, a user can manually change any indicator to and from the active state.

3.4.3 Diagnostic Help

Selecting DIAGNOSTICS from the MAIN MENU presents a list of five ITEMS from the top level of the DIAGNOSTICS tree.

When Present Status is highlighted, the highest MAGNETROL priority active diagnostic indicator (numerically lowest in Table 3.4) is displayed on the bottom LCD line. Pressing the ENTER key moves the active diagnostic indicator to the top line outdented and presents in the lower area of the LCD a brief explanation of and possible remedies for the indicated condition. A blank line separates the explanation from the remedies. Additional active diagnostic indicators, if any, appear with their explanations in descending priority order. Each additional active indicator name-explanation pair is separated by a blank line from the one above.

If the explanation and remedy text (and additional name-explanation pairs) exceeds the available space, a ↵ appears in the rightmost column of the last line indicating more text below. In this situation, the DN key scrolls text up one line at a time. Similarly, while text exists above the upper line of the text field, a ⤴ appears in the rightmost column of the top (text) line. In this situation, the UP key scrolls the text down one line at a time. Otherwise the DN and UP keys are inoperative. In all cases the ENT or DEL key reverts to the previous screen.



When the transmitter is operating normally and the high-light cursor is positioned on Present Status, the bottom LCD line displays “OK” because no diagnostic indicators are active.

EVENT HISTORY – This menu displays the last twenty events related to configuration and diagnostic event logging.

ADVANCED DIAGNOSTICS – This menu displays parameters related to some of the advanced diagnostics available within the Model R86.

INTERNAL VALUES – Displays read-only internal parameters.

ELEC TEMPERATURES – Displays temperature information as measured in the electronics module in degrees F or C.

TRANSMITTER TESTS – Allows the user to manually set the output current to a constant value. This is a method for the user to verify operation of the other equipment in the loop.

ECHO CURVES – This menu allows the user to display the live Echo Curve or Echo Rejection Curve on the LCD.



3.4.4 Diagnostic Indicator Table

Shown below and at right is a listing of the Model R86 diagnostic indicators, showing their priority, explanations and recommended remedies. (Priority 1 is highest priority.)

Priority	Indicator Name	Default Category	Explanation	Remedy (Context Sensitive Help)
1	Software Error	Failure	Unrecoverable error occurred in stored program.	Contact MAGNETROL Technical Support.
2	RAM Error	Failure	RAM (read/write) memory failing.	
3	ADC Error	Failure	Analog-to-digital converter failure.	
4	EEPROM Error	Failure	Non-volatile parameter storage failing.	
5	Analog Board Error	Failure	Unrecoverable hardware failure.	
6	Analog Output Error	Failure	Actual loop current deviates from commanded value. Analog output is inaccurate.	Perform Adjust Analog Output maintenance procedure.
7	Spare Indicator 1	OK	Reserved for future use.	
8	Default Parameters		Saved parameters are set to default values.	Perform complete Device Configuration.
9	Spare Indicator 2	OK	Reserved for future use.	
10	Sweep Time Error	Failure	Analog board sweep time error	Contact MAGNETROL Technical Support.
11	Spare Indicator 3	OK	Reserved for future use.	
12	Too Many Echoes	Failure	Excessive number of possible echoes detected	Check Settings: Dielectric, Sensitivity. Check Polarization.
13	Safety Zone Alarm	Failure	Risk of echo loss if liquid rises above Blocking Distance.	Ensure that liquid cannot reach Blocking Distance.
14	No Echoes	Failure	No signal detected.	Check settings: Dielectric Range Increase Sensitivity. View Echo Curve.
15	Spare Indicator 4	OK	Reserved for future use	
16	Config Conflict	Failure	Measurement type and primary variable selection parameters are inconsistent.	Confirm proper configuration. Check Measurement Type.
17	High Volume Alarm	Failure	Volume calculated from Level reading exceeds capacity of vessel or custom table.	Check settings: Vessel Dimensions, Custom Table entries
18	High Flow Alarm	Failure	Calculated flow exceeds maximum for flume or custom table.	Check settings: Vessel Dimensions, Custom Table entries
19	Spare Indicator 5	OK	Reserved for future use.	
20	Initializing	Function Check	Distance measurement is inaccurate while internal filters are settling.	Standard start-up message. Wait for up to 10 seconds.

Priority	Indicator Name	Default Category	Explanation	Remedy
21	Config Changed	Function Check	A parameter has been modified from the User Interface.	If desired, reset Config Changed indicator in ADVANCED CONFIG menu.
22	Spare Indicator 6	OK	Reserved for future use.	
23	High Elec Temp	Out of Spec	Electronics too hot. May compromise level measurement or damage instrument.	Shield transmitter from heat source or increase air circulation. Locate transmitter remotely in a cooler area.
24	Low Elec Temp	Out of Spec	Electronics too cold. May compromise level measurement or damage instrument.	Insulate transmitter. Locate transmitter remotely in a warmer area.
25	Calibration Req'd	Out of Spec	Factory calibration has been lost. Measurement accuracy may be diminished.	Return transmitter to factory for recalibration.
26	Echo Reject Invalid	Out of Spec	Echo Rejection inoperative. May report erroneous Level readings. Upr Echo may be lost.	Save a fresh Echo Rejection Curve.
27	Spare Indicator 7	OK	Reserved for future use.	
28	Inferred Level	Out of Spec	Level inferred to have entered Blocking Region if echo lost within Max Distance Jump of Top or Bottom Blocking Region.	Verify level reading; if incorrect, check configuration.
29	Adjust Analog Out	Out of Spec	Loop current is inaccurate.	Perform Adjust Analog Output maintenance procedure.
30	Totalizer Data Lost		Totalizer data has been lost; restarted from zero.	
31	Low Supply Voltage	Out of Spec	Loop current may be incorrect at higher values. Analog output is inaccurate.	Verify loop resistance. Replace loop power supply.
32	Spare Indicator 8	OK	Reserved for future use.	
33	Max Jump Exceeded	Maintenance Required	Transmitter has jumped to an echo at location that exceeds "Max Level Jump" from previous echo location.	Check settings: Dielectric Range Sensitivity View Echo Curve.
34	Low Echo Margin	Maintenance Required	Signal Margin is less than allowable minimum.	Check settings: Dielectric Range Sensitivity View Echo Curve.
35	High Surface Velocity	Maintenance Required	Measured Surface Velocity greater than Max Surface Velocity derived from configured Rate of Change.	Confirm actual rate of change. Adjust rate of change setting, if needed.
36	Spare Indicator 9	OK	Reserved for future use.	
37	Sequence Record	OK	A Sequence Record number has been stored in Event Log.	If desired, report Sequence Record number to factory.

3.4.5 Additional Diagnostic/Trouble Shooting Capabilities

3.4.5.1 Echo History Setup

The Model R86 contains the unique and powerful feature that allows waveforms to be automatically captured based on Diagnostic Events, Time or both. This menu contains those parameters that configure that feature.

Eleven (11) waveforms can be saved directly into the transmitter.

- Nine (9) Troubleshooting Curves
- One (1) Echo Rejection Curve
- One (1) Reference Curve

3.4.5.2 Event History

As a means for improved troubleshooting capability, a record of significant diagnostic events is stored with time and date stamps. A real-time on-board clock (which must be set by the operator), will maintain the current time.

3.4.5.3 Context-sensitive Help

NOTE: Context-sensitive HELP is available for all menu items. With the menu item highlighted, hold down the **ENTER** key for two seconds. Use **UP** and **DOWN** for navigation.

Descriptive information relevant to the highlighted parameter in the menu will be accessible via the local display and remote host interfaces. This will most often be a parameter-related screen, but could also be information about menus, actions (for example, Loop [Analog Output] Test, resets of various types), diagnostic indicators, etc.

For example: Dielectric Range — Selects the range bounding the dielectric constant of the medium in vessel. Some ranges may not be selectable depending on the antenna model.

3.4.5.4 Trend Data

Another feature of the Model R86 is the ability to log several measured values (selectable from any of the primary, secondary, or supplemental measured values) at a configurable rate (for example, once every five minutes) for a period ranging from several hours to a number of days (depending on the configured sample rate and number of values to be recorded). The data will be stored in non-volatile memory in the transmitter with date and time information for subsequent retrieval and visualization using the associated Model R86 DTM.

TREND DATA – A 15-minute trend of the PV can be displayed on the LCD.

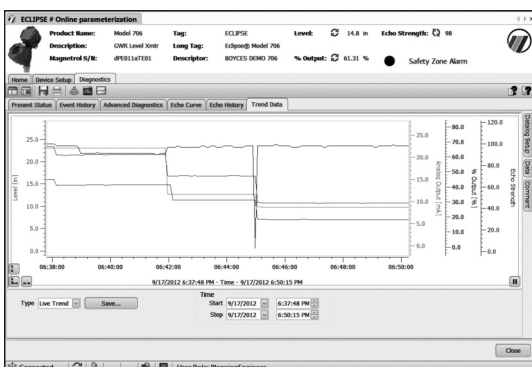

3.5 Agency Approvals



These devices are in compliance with the RED-directive 2014/53/EU, the PED-directive 2014/68/EU, the ATEX directive 2014/34/EU and RoHS directive 2011/65/EU.

<p>Explosion Proof US/Canada: FM17US0108X / FM17CA0055X Class I, Div 1, Group B, C, D, T4...T1 Zone 1 A Ex db ia IIB+H2 T4...T1 Zone 1 Ex d ia IIB+H2 T4...T1 Ta = -40 °C to +70 °C Type 4X, IP67</p> <p>Flame Proof ATEX – FM17ATEX0027X II 1/2 G Ex db ia IIB + H2 T4...T1 Ga/Gb Ta = -40 °C to +70 °C IP67</p> <p>IEC- IECEX FMG 17.0012X Ex db ia IIB + H2 T4...T1 Ga/Gb Ta = -40 °C to +70 °C IP67</p>	<p>Non- Incendive US/Canada: FM17US0108X / FM17CA0055X Class I, II, III, Div 2, Group A, B, C, D, E, F, G, T4...T1 Class 1, Zone 2 AEx nA ia IIC T4...T1 Class 1, Zone 2 Ex nA ia IIC T4...T1 Ta = -15 °C to +70 °C Type 4X, IP67</p> <p>Non-sparking ATEX - FM17ATEX0028X II 3 G Ex nA IIC Gc T4...T1 Ta = -15 °C to +70 °C IP67</p> <p>IEC – IECEX FMG 17.0012X Ex nA IIC Gc T4...T1 Ta = -15 °C to + 70 °C IP67</p>
<p>Intrinsically Safe US/Canada: FM17US0108X / FM17CA0055X Class I, II, III, Div 1, Group A, B, C, D, E, F, G, T4...T1 Class I, Zone 0 AEx ia IIC T4...T1 Class I, Zone 0 Ex ia IIC T4...T1 Ga Ta = -40 °C to +70 °C Type 4X, IP67</p> <p>ATEX – FM17ATEX0027X: II 1 G Ex ia IIC T4...T1 Ga Ta = -40 °C to +70 °C IP67</p> <p>IEC – IECEX FMG 17.0012X: Ex ia IIC T4...T1 Ga Ta = -40 °C to +70 °C IP67</p>	<p>Dust Ignition Proof US/Canada: FM17US0108X / FM17CA0055X Class II, III, Div 1, Group E, F, and G, T4...T1 Ta = -15 °C to +70 °C Type 4X, IP67</p> <p>ATEX – FM17ATEX0027X: II 2 D Ex ia tb IIIC T100 °C Db Ta = -15 °C to +70 °C IP67</p> <p>IEC – IECEX FMG 17.0012X: Ex ia tb IIIC T100 °C Db Ta = -15 °C to +70 °C IP67</p>

Telecommunications Approvals

Agency	In-Tank	Out of Tank
FCC	47 CFR, Part 15, Subpart C, Section 15.209 Unintentional Radiators	47 CFR, Part 15, Subpart C, Section 15.256
ISED	RSS-211	RSS-211
ETSI	EN 302 372 V2.1.1 (2016-12)	(Future)

FM3600:2011, FM3610:2010, FM3611:2004, FM3615:2006, FM3616:2011, FM3810:2005, ANSI/ISA60079-0:2013, ANSI/ISA 60079-1:2015, ANSI/ISA 60079-11:2013, ANSI/ISA 60079-15:2012, ANSI/ISA 60079-26:2011, NEMA 250:2003, ANSI/IEC 60529:2004, C22.2 No. 0.4:2009, C22.2 No. 0.5:2008, C22.2 No. 30:2007, C22.2 No. 94:2001, C22.2 No. 213:2012, C22.2 No. 1010.1:2009, CAN/CSA 60079-0:2011, CAN/CSA 60079-1:2011, CAN/CSA 60079-11:2014, CAN/CSA 60079-15:2012, C22.2 No. 60529:2005, EN60079-0:2012, EN60079-1:2014, EN60079-11:2012, EN60079-15:2010, EN60079-26:2007, EN60079-31:2009, EN60529+A1:1991-2000, IEC60079-0:2011, IEC60079-1:2014, IEC60079-11:2011, IEC60079-15:2010, IEC60079-26:2006, IEC60079-31:2008

“This equipment with chargeable non-conductive parts, e.g. enclosure’s paint and antenna use PTFE, Co-polymer Polypropylene or Noryl En265, is provided with a warning label referring to the safety measures that must be taken if there is electrostatic charging during operation. For use in hazardous area, the equipment and side to be installed, e.g. tank, must be connected to earth and be attention to not only the measuring object, e.g. liquids, gases, powders and etc., but also the related conditions, e.g. tank container, vessel and etc. (According to IEC 60079-32-1).”

SPECIAL CONDITIONS OF USE:

1. The enclosure contains aluminum and is considered to present a potential risk of ignition by impact or friction.
Care must be taken during installation and use to prevent impact or friction.
2. Provisions shall be made to provide transient overvoltage protection to a level not to exceed 119 VDC.
3. To maintain the T4 temperature code, care shall be taken to ensure the ‘enclosure temperature’ does not exceed 70 °C.
4. For installation with ambient temperature of 60 °C, refer to manufacturer’s instructions for guidance on proper selection of conductors.
5. The risk of electrostatic discharge shall be minimized at installation, following the direction given in this instruction manual.
6. The Pulsar R86 includes flamepath joints. Consult Magnetrol if repair of flamepath joints is necessary.
7. Temperature class for the process temperature ranges is defined by the following table.

Temperature codes for the ratings are defined by the following table:

Process Temperature Range	Temperature Code
From 0 to 130 °C	T4
From 130 to 195 °C	T3
From 195 to 295 °C	T2
From 295 to 400 °C	T1

8. PTFE seal is limited for use where process temperature range is -40 to +200 °C (T4 or T3).

FCC (ID# LPN-R86) Compliance Statement:

§15.209 The 1½" and 2" horns can only be used for installations directly into tanks.

§15.105 Information to the user.

(b) For a Class B digital device or peripheral, the instructions furnished the user shall include the following or similar statement, placed in a prominent location in the text of the manual:

Note: This equipment has been tested and found to comply with the limits for a Class B digital device, pursuant to part 15 of the FCC Rules. These limits are designed to provide reasonable protection against harmful interference in a residential installation. This equipment generates, uses and can radiate radio frequency energy and, if not installed and used in accordance with the instructions, may cause harmful interference to radio communications. However, there is no guarantee that interference will not occur in a particular installation. If this equipment does cause harmful interference to radio or television reception, which can be determined by turning the equipment off and on, the user is encouraged to try to correct the interference by one or more of the following measures:

- Reorient or relocate the receiving antenna.
- Increase the separation between the equipment and receiver.
- Connect the equipment into an outlet on a circuit different from that to which the receiver is connected.
- Consult the dealer or an experienced radio/TV technician for help.

- (i) The installation of the LPR/TLPR device shall be done by trained installers, in strict compliance with the manufacturer’s instructions.
- (ii) The use of this device is on a “no-interference, no-protection” basis. That is, the user shall accept operations of high-powered radar in the same frequency band which may interfere with or damage this device. However, devices found to interfere with primary licensing operations will be required to be removed at the user’s expense.

ISED Certification Number 2331A-R86 Statement:

This device shall be installed and operated in a completely enclosed container to prevent RF emissions, which can otherwise interfere with aeronautical navigation.

This device complies with Industry Canada’s licence-exempt RSSs. Operation is subject to the following two conditions:

- (1) This device may not cause interference; and
- (2) This device must accept any interference, including interference that may cause undesired operation of the device

3.5.1 Agency Drawing and Entity Parameters

HAZARDOUS LOCATION

PULSAR R86 LEVEL TRANSMITTER

INTRINSICALLY SAFE FOR:

CL I,II,III DIV 1 GRP A,B,C,D,E,F,G

CL I, ZONE 0 AEx ia IIC

CL I, ZONE 0 Ex ia IIC

II 1 G Ex ia IIC

Ex ia IIC

ENTITY

Ui (Vmax) = 28.6 V

Ii (Imax) = 140 mA

Pi = 1 W

Ci = 4.4nF

Li = 2.7 μH

NON-HAZARDOUS LOCATION

LIMITING VALUES

Voc <= 28.6V

Ca >= 4.4 nF

Isc <= 140 mA

La >= 2.7 μH

THE VOLTAGE (V max) AND CURRENT (I max), WHICH THE TRANSMITTER CAN RECEIVE MUST BE EQUAL TO OR GREATER THAN THE MAXIMUM OPEN CIRCUIT VOLTAGE (Voc OR V+) AND THE MAXIMUM SHORT CIRCUIT CURRENT (Isc OR IE), WHICH CAN BE DELIVERED BY THE SOURCE DEVICE. IN ADDITION, THE MAXIMUM CAPACITANCE (Ci) AND INDUCTANCE (Li) OF THE LOAD AND THE CAPACITANCE AND INDUCTANCE OF THE INTERCONNECTING WIRING, MUST BE EQUAL TO LESS THAN THE CAPACITANCE (Ca) OR THE INDUCTANCE (La), WHICH CAN BE DRIVEN BY THE SOURCE DEVICE.

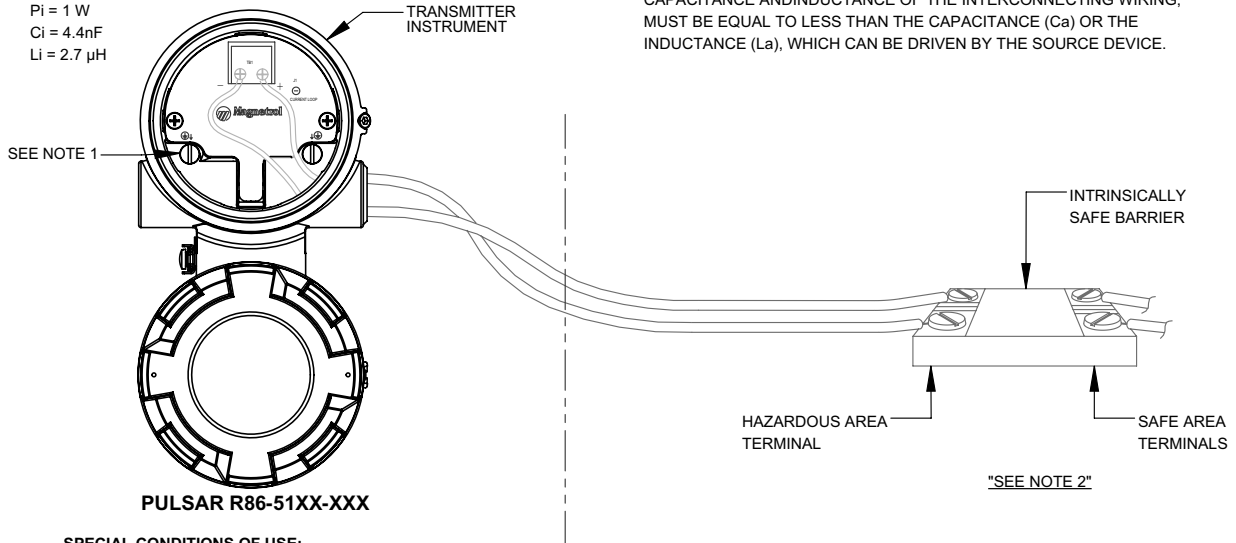

SPECIAL CONDITIONS OF USE:

1. THE ENCLOSURE CONTAINS ALUMINUM AND IS CONSIDERED TO PRESENT A POTENTIAL RISK OF IGNITION BY IMPACT OR FRICTION. CARE MUST BE TAKEN DURING INSTALLATION AND USE TO PREVENT IMPACT OR FRICTION.
2. PROVISIONS SHALL BE MADE TO PROVIDE TRANSIENT OVERVOLTAGE PROTECTION TO A LEVEL NOT TO EXCEED 119VDC.
3. TO MAINTAIN THE T4 TEMPERATURE CODE CARE SHALL BE TAKEN TO ENSURE THE "ENCLOSURE TEMPERATURE" DOES NOT EXCEED 70°C.
4. FOR INSTALLATION WITH AMBIENT TEMPERATURE OF 60°C, REFER TO THE MANUFACTURER'S INSTRUCTIONS FOR GUIDANCE ON PROPER SELECTION OF CONDUCTORS.
5. THE RISK OF ELECTROSTATIC DISCHARGE SHALL BE MINIMIZED AT INSTALLATION, FOLLOWING THE DIRECTION GIVEN IN THE INSTRUCTION MANUAL.
6. THE PULSAR R86 INCLUDES FLAMPATH JOINTS, CONSULT MAGNETROL IF REPAIR OF FLAMEPATH JOINTS IS NECESSARY.
7. TEMPERATURE CLASS FOR THE PROCESS TEMPERATURE RANGES IS DEFINED BY THE FOLLOWING TABLE.

PROCESS TEMPERATURE RANGE	TEMPERATURE CODE
FROM 0°C TO 130°C	T4
FROM 130°C TO 190°C	T3
FROM 195°C TO 295°C	T2
FROM 295°C TO 400°C	T1

8. PTFE SEAL IS LIMITED FOR USE WHERE PROCESS TEMPERATURE RANGE IS - 40 TO + 200°C. (T4 OR T3)

NOTES:

1. FOR EXPLOSION PROOF INSTALLATIONS THE I.S. GROUND TERMINAL SHALL BE CONNECTED TO APPROPRIATE INTRINSICALLY SAFE GROUND IN ACCORDANCE WITH THE CANADIAN ELECTRICAL CODE (CEC) OR THE NATIONAL ELECTRICAL CODE (NEC). FOR INTRINSICALLY SAFE INSTALLATIONS THE I.S. GROUND TERMINAL DOES NOT REQUIRE GROUNDING.
2. MANUFACTURER'S INSTALLATION INSTRUCTIONS SUPPLIED WITH THE PROTECTIVE BARRIER AND THE CEC OR THE NEC MUST BE FOLLOWED WHEN INSTALLING THIS EQUIPMENT. BARRIER MUST BE CERTIFIED FOR CANADIAN & U.S. INSTALLATION.
3. CONTROL EQUIPMENT CONNECTED TO PROTECTIVE BARRIERS MUST NOT USE OR GENERATE MORE THAN 250 VDC OR VRMS.
4. AGENCY APPROVED DUST TIGHT SEALS MUST BE USED WHEN TRANSMITTER IS INSTALLED IN CLASS II & III ENVIRONMENTS.
5. FOR SUPPLY CONNECTIONS, USE WIRE SUITABLE FOR THE OPERATING TEMPERATURE.
6. FM APPROVED BARRIERS WITH LINEAR OUTPUT CHARACTERISTICS MUST BE USED.

P/N 099-5077-001

AGENCY LISTED DRAWING
ALL REVISIONS TO THIS DRAWING REQUIRE QA APPROVAL

705 ENTERPRISE ST., AURORA, IL 60504
PHONE: (630)723-6600
099-5077 SHEET 2 OF 5

3.5.1 Agency Drawing and Entity Parameters

HAZARDOUS LOCATION
PULSAR R86 LEVEL TRANSMITTER
EXPLOSION PROOF FOR:
CLASS I, DIV. 1, GROUP A
CLASS II, DIV. 1, GROUP A
CLASS II, DIV. 2, GROUP A
CLASS II, DIV. 2, GROUP B
CLASS II, DIV. 2, GROUP C
CLASS II, DIV. 2, GROUP D
CLASS II, DIV. 2, GROUP E
CLASS II, DIV. 2, GROUP F
CLASS II, DIV. 2, GROUP G
CLASS II, DIV. 2, GROUP H
CLASS II, DIV. 2, GROUP I
CLASS II, DIV. 2, GROUP J
CLASS II, DIV. 2, GROUP K
CLASS II, DIV. 2, GROUP L
CLASS II, DIV. 2, GROUP M
CLASS II, DIV. 2, GROUP N
CLASS II, DIV. 2, GROUP O
CLASS II, DIV. 2, GROUP P
CLASS II, DIV. 2, GROUP Q
CLASS II, DIV. 2, GROUP R
CLASS II, DIV. 2, GROUP S
CLASS II, DIV. 2, GROUP T
CLASS II, DIV. 2, GROUP U
CLASS II, DIV. 2, GROUP V
CLASS II, DIV. 2, GROUP W
CLASS II, DIV. 2, GROUP X
CLASS II, DIV. 2, GROUP Y
CLASS II, DIV. 2, GROUP Z

ENTITY
Um = 38Vdc

ZONE 1

ZONE 1

ZONE 1

ZONE 1

SPECIAL CONDITIONS OF USE:

1. THE ENCLOSURE CONTAINS ALUMINUM AND IS CONSIDERED TO PRESENT A POTENTIAL RISK OF IGNITION BY IMPACT OR FRICTION. CARE MUST BE TAKEN DURING INSTALLATION AND USE TO PREVENT IMPACT OR FRICTION.
2. PROVISIONS SHALL BE MADE TO PROVIDE TRANSIENT OVERVOLTAGE PROTECTION TO A LEVEL NOT TO EXCEED 119VDC.
3. TO MAINTAIN THE T4 TEMPERATURE CODE CARE SHALL BE TAKEN TO ENSURE THE 'ENCLOSURE TEMPERATURE' DOES NOT EXCEED 70°C.
4. FOR INSTALLATION WITH AMBIENT TEMPERATURE OF 80°C, REFER TO THE MANUFACTURER'S INSTRUCTIONS FOR GUIDANCE ON PROPER SELECTION OF CONDUCTORS.
5. THE RISK OF ELECTROSTATIC DISCHARGE SHALL BE MINIMIZED AT INSTALLATION, FOLLOWING THE DIRECTION GIVEN IN THE INSTRUCTION MANUAL.
6. THE PULSAR R86 INCLUDES FLAMEPATH JOINTS. CONSULT MAGNETROL IF REPAIR OF FLAMEPATH JOINTS IS NECESSARY.
7. TEMPERATURE CLASSIFICATION, PROCESS TEMPERATURE RANGES, DEFINED BY THE FOLLOWING TABLE.

PROCESS TEMPERATURE RANGE	TEMPERATURE CODE
FROM 0°C TO 130°C	T4
FROM 130°C TO 195°C	T3
FROM 195°C TO 295°C	T2
FROM 295°C TO 400°C	T1

NOTES:

1. AGENCY APPROVED DUST TIGHT SEALS MUST BE USED WHEN TRANSMITTER IS INSTALLED IN CLASS II & III ENVIRONMENTS.
2. FOR SUPPLY CONNECTIONS, USE WIRE SUITABLE FOR THE OPERATING TEMPERATURE.
3. TOP WIRING COMPARTMENT HAS EXPLOSION PROOF APPROVAL. BOTTOM COMPARTMENT IS INTRINSICALLY SAFE ONLY.
4. POWER SUPPLY CONTROL EQUIPMENT CONNECTED TO THE PULSAR R86 MUST NOT USE OR GENERATE MORE THAN 38VDC.

HAZARDOUS LOCATION
PULSAR R86 LEVEL TRANSMITTER
EXPLOSION PROOF FOR:
CLASS I, DIV. 1, GROUP A
CLASS II, DIV. 1, GROUP A
CLASS II, DIV. 2, GROUP A
CLASS II, DIV. 2, GROUP B
CLASS II, DIV. 2, GROUP C
CLASS II, DIV. 2, GROUP D
CLASS II, DIV. 2, GROUP E
CLASS II, DIV. 2, GROUP F
CLASS II, DIV. 2, GROUP G
CLASS II, DIV. 2, GROUP H
CLASS II, DIV. 2, GROUP I
CLASS II, DIV. 2, GROUP J
CLASS II, DIV. 2, GROUP K
CLASS II, DIV. 2, GROUP L
CLASS II, DIV. 2, GROUP M
CLASS II, DIV. 2, GROUP N
CLASS II, DIV. 2, GROUP O
CLASS II, DIV. 2, GROUP P
CLASS II, DIV. 2, GROUP Q
CLASS II, DIV. 2, GROUP R
CLASS II, DIV. 2, GROUP S
CLASS II, DIV. 2, GROUP T
CLASS II, DIV. 2, GROUP U
CLASS II, DIV. 2, GROUP V
CLASS II, DIV. 2, GROUP W
CLASS II, DIV. 2, GROUP X
CLASS II, DIV. 2, GROUP Y
CLASS II, DIV. 2, GROUP Z

ENTITY
Um = 38Vdc

ZONE 1

ZONE 0

ZONE 1

ZONE 1

SPECIAL CONDITIONS OF USE:

1. THE ENCLOSURE CONTAINS ALUMINUM AND IS CONSIDERED TO PRESENT A POTENTIAL RISK OF IGNITION BY IMPACT OR FRICTION. CARE MUST BE TAKEN DURING INSTALLATION AND USE TO PREVENT IMPACT OR FRICTION.
2. PROVISIONS SHALL BE MADE TO PROVIDE TRANSIENT OVERVOLTAGE PROTECTION TO A LEVEL NOT TO EXCEED 70°C.
3. TO MAINTAIN THE T4 TEMPERATURE CODE CARE SHALL BE TAKEN TO ENSURE THE 'ENCLOSURE TEMPERATURE' DOES NOT EXCEED 70°C.
4. FOR INSTALLATION WITH AMBIENT TEMPERATURE OF 80°C, REFER TO THE MANUFACTURER'S INSTRUCTIONS FOR GUIDANCE ON PROPER SELECTION OF CONDUCTORS.
5. THE RISK OF ELECTROSTATIC DISCHARGE SHALL BE MINIMIZED AT INSTALLATION, FOLLOWING THE DIRECTION GIVEN IN THE INSTRUCTION MANUAL.
6. THE PULSAR R86 INCLUDES FLAMEPATH JOINTS. CONSULT MAGNETROL IF REPAIR OF FLAMEPATH JOINTS IS NECESSARY.
7. TEMPERATURE CLASSIFICATION, PROCESS TEMPERATURE RANGES, DEFINED BY THE FOLLOWING TABLE.

PROCESS TEMPERATURE RANGE	TEMPERATURE CODE
FROM 0°C TO 130°C	T4
FROM 130°C TO 195°C	T3
FROM 195°C TO 295°C	T2
FROM 295°C TO 400°C	T1

NOTES:

1. AGENCY APPROVED DUST TIGHT SEALS MUST BE USED WHEN TRANSMITTER IS INSTALLED IN CLASS II & III ENVIRONMENTS.
2. FOR SUPPLY CONNECTIONS, USE WIRE SUITABLE FOR THE OPERATING TEMPERATURE.
3. TOP WIRING COMPARTMENT HAS EXPLOSION PROOF APPROVAL. BOTTOM COMPARTMENT IS INTRINSICALLY SAFE ONLY.
4. POWER SUPPLY CONTROL EQUIPMENT CONNECTED TO THE PULSAR R86 MUST NOT USE OR GENERATE MORE THAN 38VDC.

Magnetrol®
706 ENTERPRISE ST. AURORA, IL 60604
PHONE: (630) 773-6600
099-5077 SHEET 4 OF 5
P/N 099-5077-001

AGENCY LISTED DRAWING
ALL REVISIONS TO THIS DRAWING REQUIRE QA APPROVAL

Magnetrol®
706 ENTERPRISE ST. AURORA, IL 60604
PHONE: (630) 773-6600
099-5077 SHEET 3 OF 5
P/N 099-5077-001

AGENCY LISTED DRAWING
ALL REVISIONS TO THIS DRAWING REQUIRE QA APPROVAL

3.5.1 Agency Drawing and Entity Parameters

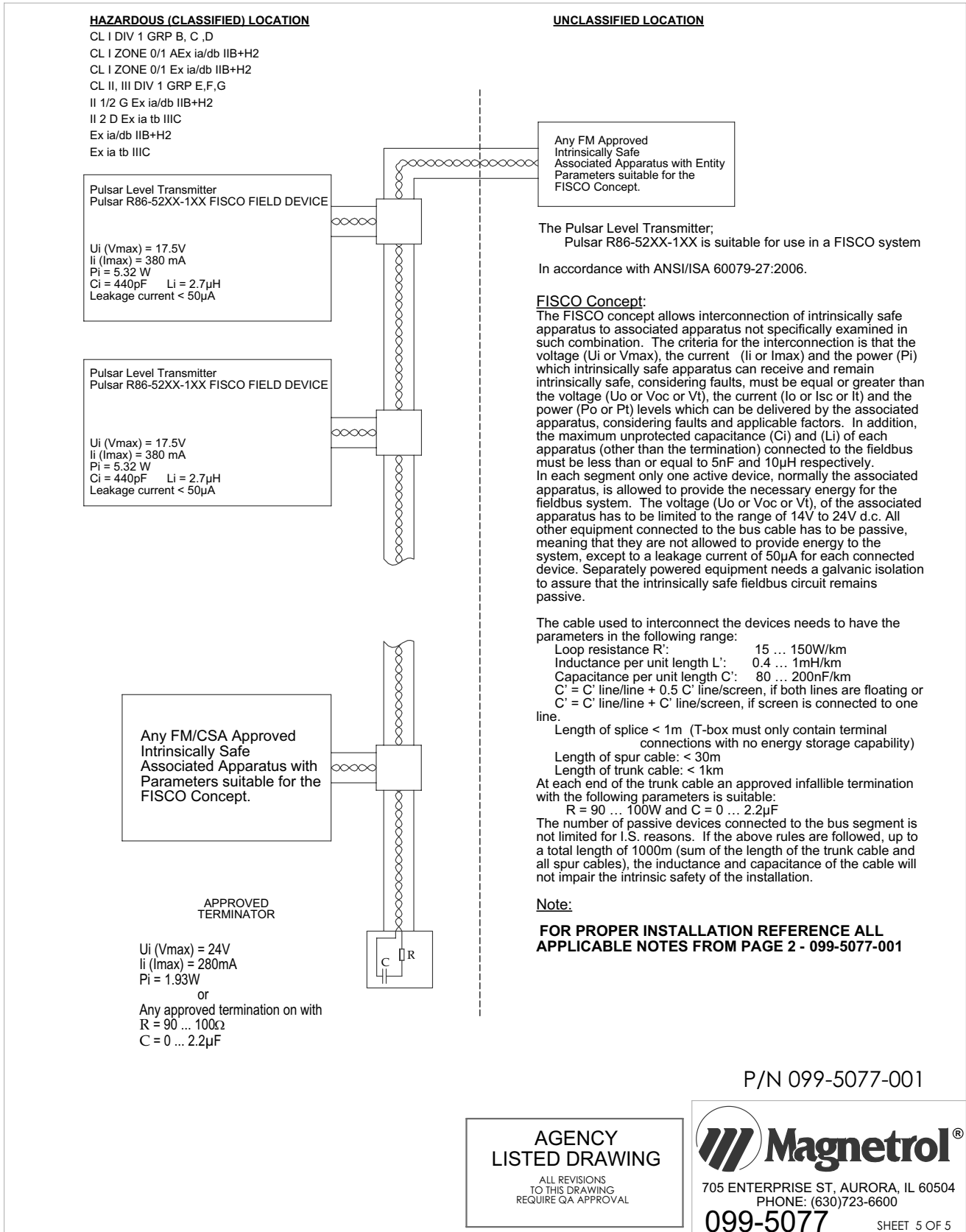

3.6 Specifications

3.6.1 Functional – Transmitter

System Design

Measurement Principle Pulse burst radar 26 GHz

Input

Measured Variable Level, determined by the time-of-flight of radar pulse reflections

Span 0,2 to 40 m (0.5' to 130')

Output

Type 4 to 20 mA with HART: 3.8 mA to 20.5 mA useable (per NAMUR NE43)

FOUNDATION fieldbus™: H1 (ITK Ver. 6.2.0)

Resolution Analog: .003 mA

Digital Display: 1 mm

Loop Resistance GP/IS: 591 ohms @ 24 VDC and 22 mA

XP/Flameproof: 500 ohms @ 24 VDC and 22 mA

Diagnostic Alarm Selectable: 3.6 mA, 22 mA (meets requirements of NAMUR NE 43), or HOLD last output

Diagnostic Indication Meets requirements of NAMUR NE107

Damping Adjustable 0-10

User Interface

Keypad 4-button menu-driven data entry

Display Graphic Liquid Crystal Display

Digital Communication HART Version 7—with Field Communicator, FOUNDATION fieldbus™ AMS, or FDT

DTM (PACTware™), EDDL

Menu Languages Transmitter LCD: English, French, German, Spanish, Russian

HART DD: English, French, German, Spanish, Russian, Chinese, Portuguese

FOUNDATION fieldbus Host System: English

Voltage (Measured at instrument terminals) HART: General Purpose (Weather proof)/Intrinsically Safe/Explosion-proof:
11 VDC minimum at terminals under certain conditions

FISCO, FNICO, Explosion Proof, General Purpose and Weather Proof

FOUNDATION fieldbus™: 9 to 17.5 VDC

Housing

Material IP67/die-cast aluminum A413 (<0.6% copper); optional stainless steel

Net/Gross Weight Aluminum: 2,0 kg (4.5 lbs.)

Stainless Steel: 4,5 kg (10.0 lbs.)

Overall Dimensions See section 3.6.7

Cable Entry ½" NPT or M20

SIL 2 Hardware (Safety Integrity Level) Safe Failure Fraction = 93.2% (HART only)

Functional Safety to SIL 2 as 1oo1 in accordance with IEC 61508

(Full FMEDA report available upon request)

3.6 Specifications

3.6.2 Functional – Environment

Operating Temperature	General purpose: -40 °C to +80 °C (-40 °F to +175 °F); Agency approved: -40 °C to +70 °C (-40 °F to +160 °F); LCD viewable -20 °C to +70 °C (-5 °F to +160 °F)	
Storage Temperature	-45 °C to +85 °C (-50 °F to +185 °F)	
Humidity	0–99%, non-condensing	
Electromagnetic Compatibility	Meets CE requirement (EN 61326) and NAMUR NE 21	
Surge Protection	Meets CE EN 61326 (1000V)	
Shock/Vibration	ANSI/ISA-S71.03 Class SA1 (Shock); ANSI/ISA-S71.03 Class VC2 (Vibration)	
Reference Conditions	Reflection from ideal reflector at +20 °C (+70 °F)	
Linearity	±3 mm (0.1") or 0.1% of tank height (whichever is greater)	
Measured Error	±3 mm (0.1") or 0.1% of tank height (whichever is greater) (Performance will degrade slightly within 1.5 m (60") of antenna)	
Resolution	1mm or 0.1"	
Repeatability	±3 mm (0.1") or 0.05% of tank height (whichever is greater)	
Response Time	<2 seconds (configuration dependent)	
Initialization Time	< 30 seconds	
Ambient Temperature Effect	Digital	Average 3 mm (0.12") / 10 K, max of ±10 mm (0.4") over the entire temperature range -40 °C to +80 °C (-40 °F to +175 °F)
	Analog	Current Output (additional error with reference to 16 mA span) Average 0.03 % / 10 K. max 0.45 % over entire temperature range -40 °C to +80 °C (-40 °F to +175 °F)
Maximum Rate of Change	450 cm (180")/minute	
FOUNDATION fieldbus™ :	ITK Version	6.2.0
	H1 Device Class	Link Master (LAS)—selectable ON/OFF
	H1 Profile Class	31PS, 32L
	Function Blocks	(8) AI, (3) Transducer, (1) Resource, (2) PID (1) Arithmetic, (1) Signal Characterizer, (1) Input Selector, (1) Integrator
	Quiescent Current	17 mA
	Execution Time	10 ms (15 ms PID Block)
	Device Revision	01
	DD Version	0x01

3.6.2.1 Safe Operating Areas

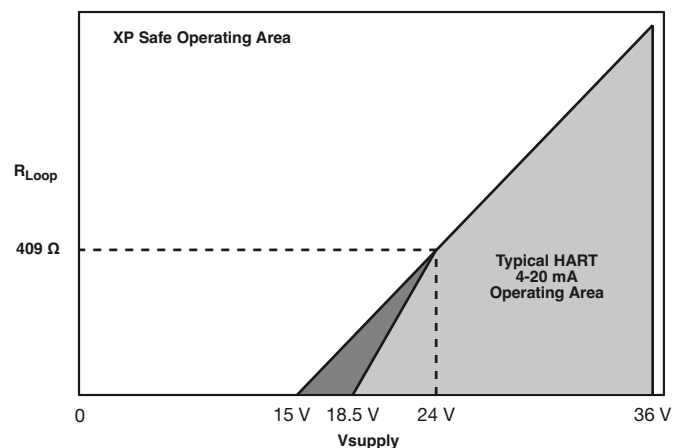
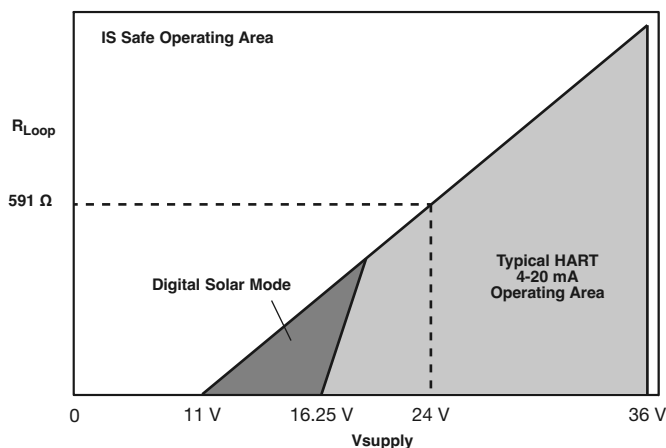

3.6.2.2 Transmitter Terminal Voltage

Operational Mode	Current Consumption	Vmin	Vmax
HART			
General Purpose	4mA 20mA	16.25V 11V	36V 36V
Intrinsically Safe	4mA 20mA	16.25V 11V	28.6V 28.6V
Explosion Proof	4mA 20mA	18.5V 15V	36V 36V
Fixed Current-Solar Power Operation (PV transmitter via HART)			
General Purpose	10mA ^①	11V	36V
Intrinsically Safe	10mA ^①	11V	28.6V
HART Multi-Drop Mode (Fixed Current)			
Standard	4mA ^①	16.25V	36V
Intrinsically Safe	4mA ^①	16.25V	28.6V
FOUNDATION fieldbus™ (Future)			
Supply Voltage	9V to 17.5V	9V to 17.5V	9V to 17.5V

① Start-up current 12 mA minimum

3.6.3 O-ring (seal) Selection Chart

Material	Code	Maximum Temperature	Maximum Pressure	Min. Temp.	Recommended For Use In	Not Recommended For Use In
Viton® GFLT	0	+200 °C @ 16 bar (+400 °F @ 232 psi)	51.7 bar @ +20 °C (750 psi @ +70 °F)	-40 °C (-40 °F)	General purpose, ethylene	Ketones (MEK, acetone), skydrol fluids, amines, anhydrous ammonia, low molecular weight esters and ethers, hot hydrofluoric or chlorosulfuric acids, sour HCs
Kalrez® 4079	2	+200 °C @ 16 bar (+400 °F @ 232 psi)	51.7 bar @ +20 °C (750 psi @ +70 °F)	-40 °C (-40 °F)	Inorganic and organic acids (including HF and nitric), aldehydes, ethylene, glycols, organic oils, silicone oils, vinegar, sour HCs	Black liquor, hot water/steam, hot aliphatic amines, ethylene oxide, propylene oxide, molten sodium, molten potassium
① Simriz SZ485 (formerly Aegis PF128)	8	+200 °C @ 16 bar (+400 °F @ 232 psi)	51.7 bar @ +20 °C (750 psi @ +70 °F)	-20 °C (-4 °F)	Inorganic and organic acids (including HF and nitric), aldehydes, ethylene, glycols, organic oils, silicone oils, vinegar, sour HCs, steam, amines, ethylene oxide, propylene oxide, NACE applications	Black liquor, Freon 43, Freon 75, Galden, KEL-F liquid, molten sodium, molten potassium
Kalrez® 6375	A	+200 °C @ 16 bar (+400 °F @ 232 psi)	51.7 bar @ +20 °C (750 psi @ +70 °F)	-40 °C (-40 °F)	Inorganic and organic acids (including hydro fluids and nitric), aldehydes, ethylene, organic oils, glycols, silicone oils, vinegar, sour HCs	Hot water/steam, hot aliphatic amines, ethylene oxide, propylene oxide
Quartz	N	+400 °C @ 94.8 bar (+750 °F @ 1375 psi)	160 bar @ +20 °C (2320 psi @ +70 °F)	-70 °C (-100 °F)	General high temperature/high pressure applications, hydrocarbons, full vacuum (hermetic), ammonia, chlorine	Hot alkaline solutions HF acid, media with ph>12, direct exposure to saturated steam

① Maximum +150 °C (+300 °F) for use on steam.

3.6.4 Functional – Antenna

Antenna Material	316 SS or Hastelloy C
Process Seal Material	PTFE with O-rings or Quartz
Maximum Process Temperature	+400 °C @ 94,8 bar (+750 °F @ 1375 psi)
Maximum Process Pressure	-1,0 to 160 bar @ +20 °C (-14.7 to 2320 psi @ +70 °F)
Vacuum Service	Hermeticity to $<5 \times 10^{-7}$ cc/sec helium
Minimum Dielectric (application dependent)	1,7 (1,4 with stillwells)

3.6.5 Antenna Pressure / Temperature Ratings

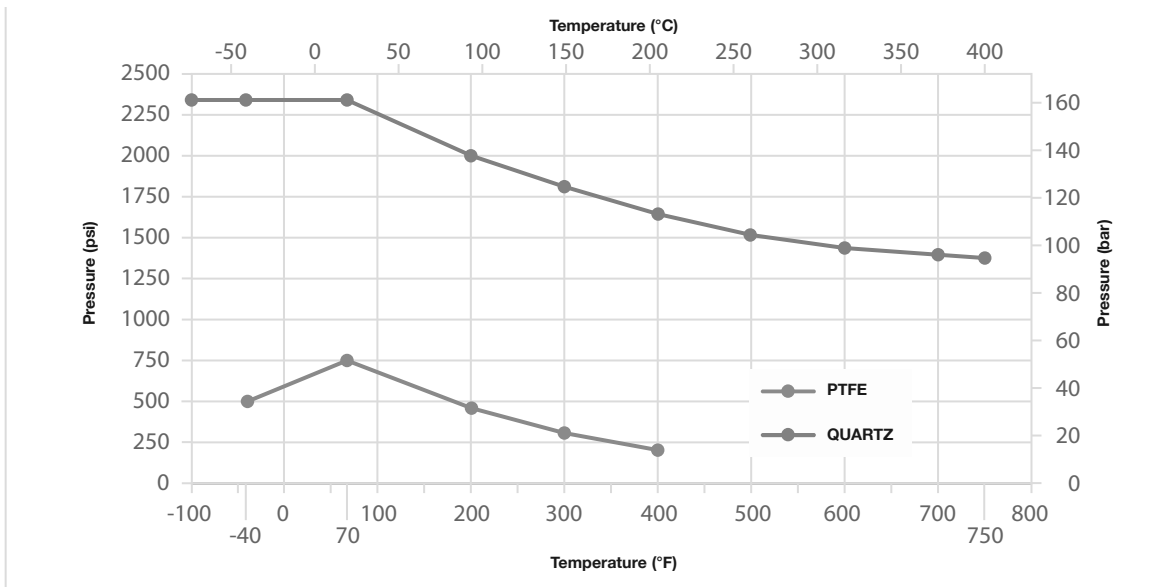

3.6.6 Operating Temperature Range

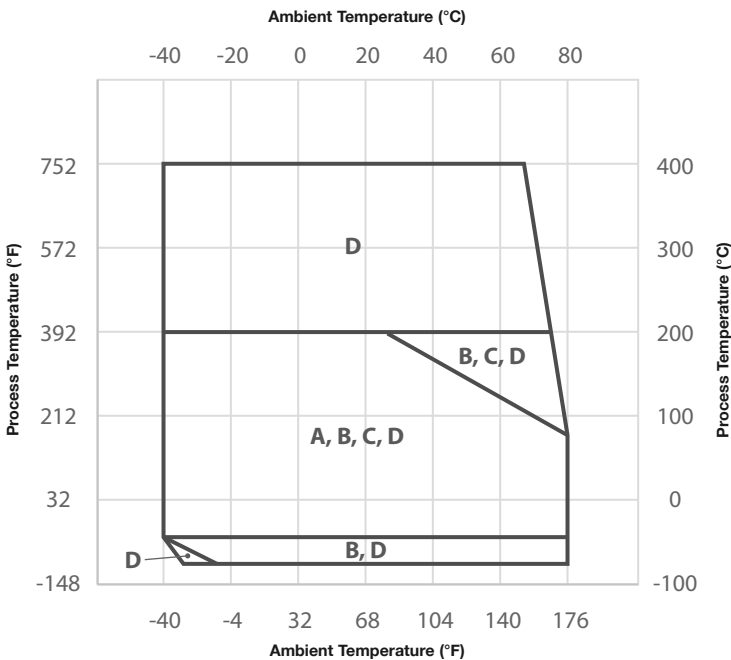

- Safe Operating Regions**
- A: Standard PTFE Seal
 - B: Standard PTFE Seal with Extension (P/N 032-6922-001)
 - C: HTHP Quartz Seal
 - D: HTHP Quartz Seal with Extension (P/N 032-6922-001)

Model R86 T-codes	No Temperature Extension			With Temperature Extension Part No. 032-6922-001		
	Max. Temp. of Process	Max. Ambient Temp.	T-code	Max. Temp. of Process	Max. Ambient Temp.	T-code
Standard Seal 10th digit = 0, 2, 8 or A	+70 °C	+70 °C	T4	+70 °C	+70 °C	T4
	+135 °C	+42 °C		+135 °C	+67 °C	
	+200 °C	+15 °C	T3	+200 °C	+64 °C	T3
HTHP Seal 10th digit = N	+70 °C	+70 °C	T4	+70 °C	+70 °C	T4
	+135 °C	+42 °C		+135 °C	+67 °C	
	+200 °C	+15 °C	T3	+200 °C	+64 °C	T3
	—	—	—	+300 °C	+60 °C	T2
	—	—	—	+400 °C	+55 °C	T1

3.6.7 Physical – mm (inches)

TRANSMITTER

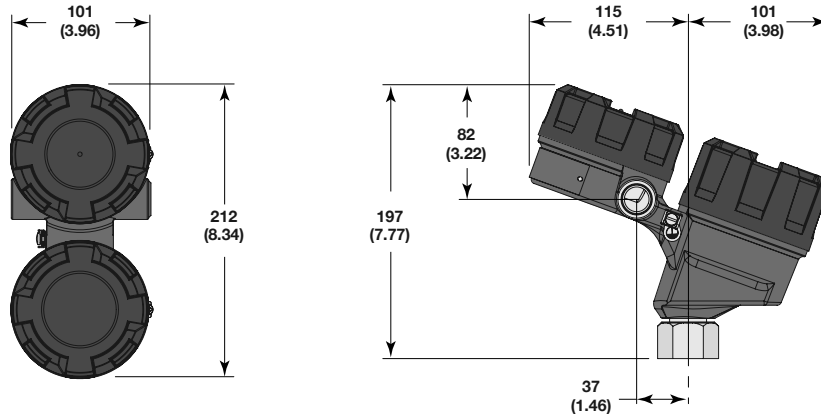

HORN ANTENNA

	Model Number	3rd Digit (Horn Size)			
	11th Digit (Extension)	1 (1½")	2 (2")	3 (3")	4 (4")
Dim. H	0 (None)	81 (3.2)	114 (4.5)	216 (8.5)	292 (11.5)
Dim. L	1 (4")	152 (6)	—	—	—
	2 (8")	203 (8)	211 (8.3)	—	—
	3 (12")	305 (12)	305 (12)	315 (12.4)	366 (14.4)
	4 (24")	610 (24)	610 (24)	610 (24)	610 (24)
	5 (48")	1219 (48)	1219 (48)	1219 (48)	1219 (48)
	6 (72")	1829 (72)	1829 (72)	1829 (72)	1829 (72)
Dim. D		40 (1.56)	48 (1.89)	75 (2.95)	95 (3.74)

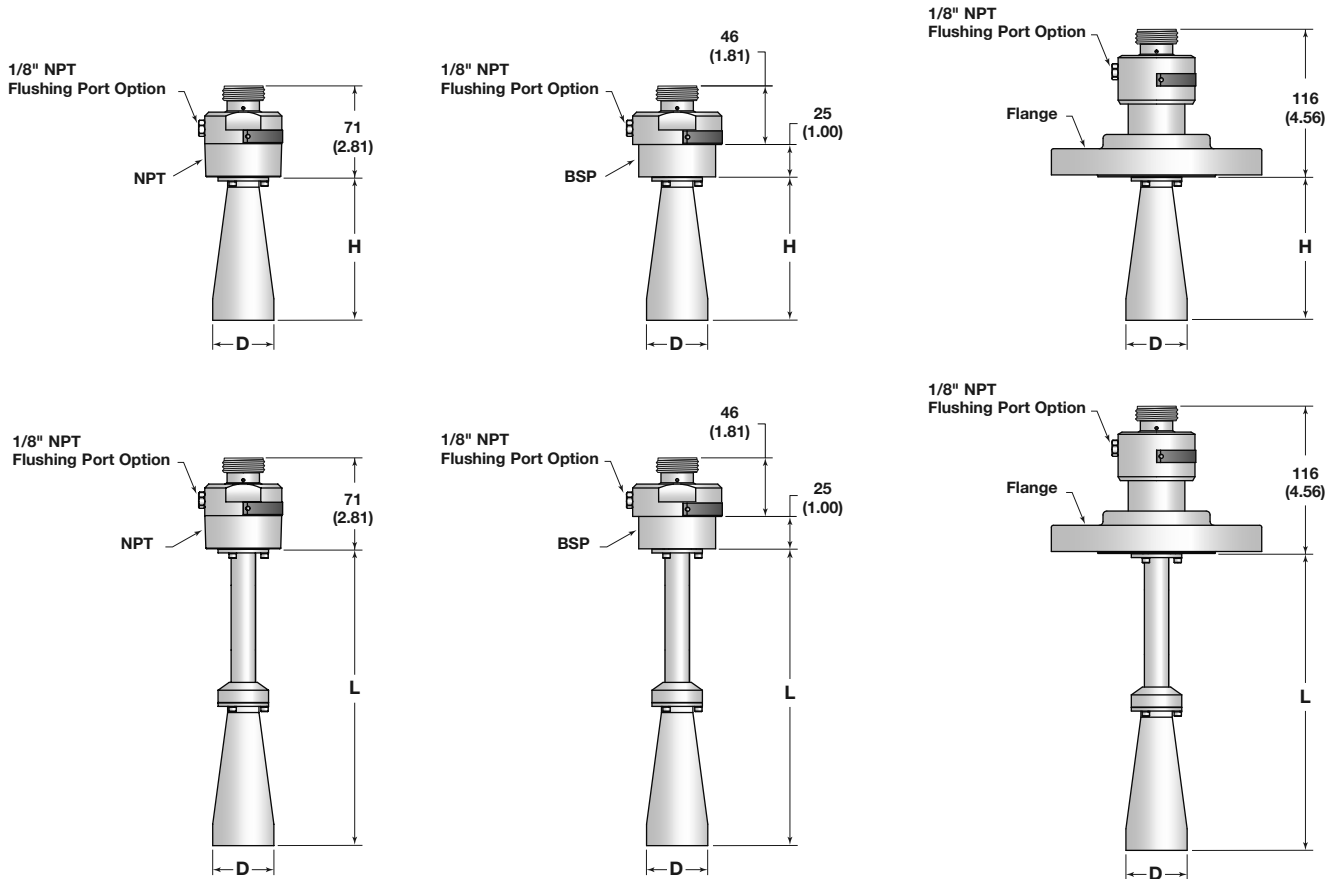

3.7 Parts

3.7.1 Replacement Parts

All replacement parts are for standard models only. Consult factory for replacement parts on modified units (model number preceded by an X).

EXPEDITE SHIP PLAN (ESP)

Several parts are available for quick shipment, within max. 1 week after factory receipt of purchase order, through the Expedite Ship Plan (ESP).

Parts covered by ESP service are conveniently grey coded in the selection tables.

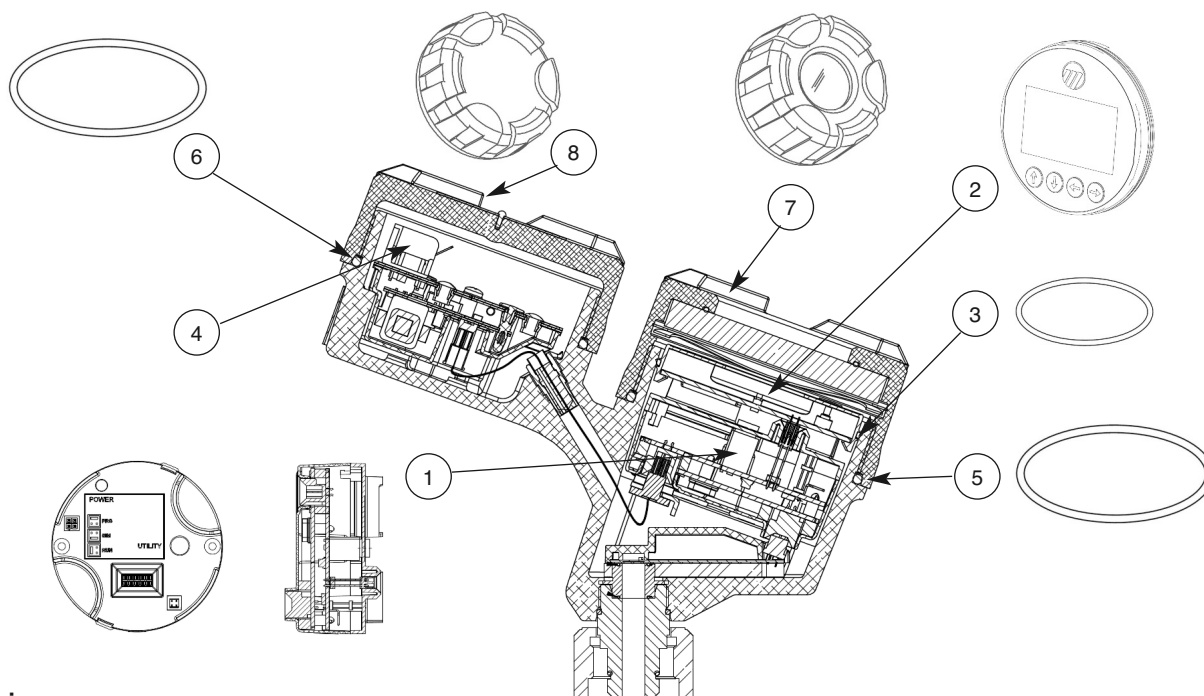

Electronics:

Partn°:

	R	8	6				
--	---	---	---	--	--	--	--

Serial n°:

--	--	--	--	--	--	--	--	--	--

Digit in partn°:

X	1	2	3	4	5	6	7	8	9	10
---	---	---	---	---	---	---	---	---	---	----

See nameplate, always provide complete part number and serial number when ordering spares.

→ X = product with a specific customer requirement

Consult factory to obtain the correct replacement part numbers for items not listed in the tables below.

(1) Electronic module		
Digit 5	Digit 6	Replacement part
1	1	Z31-2864-001
2	0	Z31-2864-002

(2) Display module	
Digit 7	Replacement part
0	not applicable
A	Z31-2850-001

(3) Display "O"-ring	
Digit 7	Replacement part
0	not applicable
A	012-2016-001

	Replacement part
(5) O-ring	012-2601-237
(6) O-ring	012-2601-237

(4) Wiring PC board			
Digit 5	Digit 6	Digit 8	Replacement part
1	1	0, 1, A, D	Z30-9180-001
		3, B	Z31-2865-001
		C	Z30-9180-002
2	0	0, 1, A, D	Z30-9166-003
		C	Z30-9166-004

(7) Housing cover		
Digit 7	Digit 9	Replacement part
0	1	004-9225-002
	2	004-9225-003
A	1	036-4413-013
	2	036-4413-016

(8) Housing cover	
Digit 9	Replacement part
1	004-9225-002
2	004-9225-003

3.8 Model Numbers

3.8.1 PULSAR Model R86 Radar Transmitter

1-3 | MEASUREMENT SYSTEM

R 8 6	Through-Air Radar Level Transmitter - 26 GHz Pulse Burst Radar
-------	--

4 | POWER

5	24 VDC, Two Wire
---	------------------

5 | SIGNAL OUTPUT

1	4-20 mA with HART
2	FOUNDATION fieldbus™ H1

6 | SAFETY OPTIONS

0	None (FOUNDATION fieldbus only, 5th digit = 2)
1	SIL 2 Hardware - HART only (5th digit = 1)

7 | ACCESSORIES/MOUNTING

0	No Digital Display and Keypad - Integral
A	Digital Display and Keypad - Integral

8 | CLASSIFICATION

0	General Purpose, Weatherproof (IP 67)
1	Intrinsically Safe (FM & CSA)
3	Explosion-proof (FM & CSA)
A	Intrinsically Safe (ATEX/IEC)
B	Flame-proof (ATEX/IEC) - only available with antenna 10 th digit = N
C	Non-sparking (ATEX)
D	Dust Ex (ATEX)

9 | HOUSING

1	Die-cast Aluminum, Dual Compartment, 20-degree
2	Investment Cast, 316ss, Dual Compartment, 20-degree

10 | CONDUIT CONNECTION

0	½" NPT
1	M20
2	½" NPT with sunshade
3	M20 with sunshade

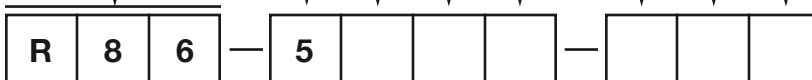

3.8.2 PULSAR Model R86 Radar Antenna

1-2 | TECHNOLOGY

R B	PULSAR Radar Antennas - 26 GHz
-----	--------------------------------

3 | CONFIGURATION/STYLE

1	1½" Horn
2	2" Horn
3	3" Horn
4	4" Horn

4-5 | PROCESS CONNECTION - SIZE/TYPE

31	1½" NPT thread	41	2" NPT Thread
32	1½" BSP (G 1½") thread	42	2" BSP (G2") Thread

ANSI Flanges

EN (DIN) Flanges

43	2" 150# ANSI raised face flange	DA	DN 50, PN 16	EN 1092-1 Type A
44	2" 300# ANSI raised face flange	DB	DN 50, PN 25/40	EN 1092-1 Type A
45	2" 600# ANSI raised face flange	DD	DN 50, PN 63	EN 1092-1 Type B2
53	3" 150# ANSI raised face flange	EA	DN 80, PN 16	EN 1092-1 Type A
54	3" 300# ANSI raised face flange	EB	DN 80, PN 25/40	EN 1092-1 Type A
55	3" 600# ANSI raised face flange	ED	DN 80, PN 63	EN 1092-1 Type B2
63	4" 150# ANSI raised face flange	FA	DN 100, PN 16	EN 1092-1 Type A
64	4" 300# ANSI raised face flange	FB	DN 100, PN 25/40	EN 1092-1 Type A
65	4" 600# ANSI raised face flange	FD	DN 100, PN 63	EN 1092-1 Type B2
73	6" 150# ANSI raised face flange	GA	DN 150, PN 16	EN 1092-1 Type A
74	6" 300# ANSI raised face flange	GB	DN 150, PN 25/40	EN 1092-1 Type A
75	6" 600# ANSI raised face flange	GD	DN 150, PN 63	EN 1092-1 Type B2

6 | CONSTRUCTION CODES

0	Industrial
K	ASME B31.1
L	ASME B31.3
M	ASME B31.3 & NACE MR0175 / MR0103
N	NACE MR0175 / MR0103

7 | FLANGE OPTIONS

0	None
---	------

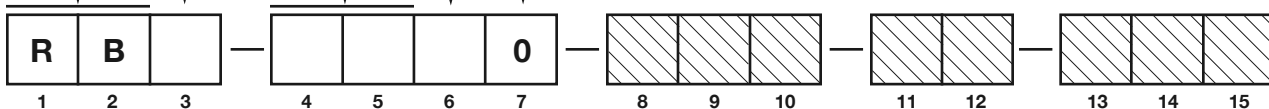

3.8.2 PULSAR Model R86 Radar Antenna

8 | MATERIAL OF CONSTRUCTION

A	316SS/316L SS
B	Hastelloy C
R	316SS/316L SS with Carbon Steel Flange
S	Hastelloy C with Carbon Steel Flange

9 | FUTURE

0	
---	--

10 | O-RING MATERIALS/SEAL OPTIONS

0	Viton GFLT
2	Kalrez 4079
8	Simriz SZ485 (formerly Aegis PF128) — NACE
A	Kalrez 6375
N	None - Quartz seal (mandatory for Flame-proof (ATEX/IEC) approval)

11 | ANTENNA EXTENSIONS

0	None
1	For nozzle height ≤ 100 mm (4") - only available with antenna 3 rd digit = 1
2	For nozzle height ≤ 200 mm (8") - not available with antenna 3 rd digit = 3 or 4
3	For nozzle height ≤ 300 mm (12")
4	For nozzle height ≤ 600 mm (24")
5	For nozzle height ≤ 1200 mm (48")
6	For nozzle height ≤ 1800 mm (72")

12 | SPECIAL OPTIONS

0	None
1	½" NPT Flushing Connection

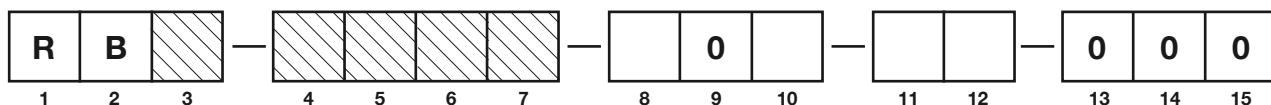

4.0 Advanced Configuration/Troubleshooting Techniques

This section contains information regarding some of the advanced configuration and troubleshooting capability contained within the Model R86 transmitter. Some of these diagnostic options are best suited for use with PACTware and the Model R86 DTM, and should be implemented only after contacting Magnetrol Technical Support.

4.1 Echo Rejection

After choosing a proper mounting location, another way to ignore unwanted signals within the measuring range is by utilizing the Echo Rejection feature.

Setup using DTM/PACTware™

Select the Diagnostics tab and then the Echo Curve tab. After refreshing the waveform, click on the New Rejection Curve button.

The screenshot displays the PULSAR # Online parameterization software interface. The main window shows the Echo Curve tab, which includes a graph of Echo Strength versus Level [ft]. The graph shows a 'False Level' peak at approximately 11.00 ft and an 'Actual Level' peak at approximately 8.50 ft. The configuration panel below the graph includes the following settings:

Curve 1:	Live	Dielectric Range:	Above 10	Target Selection:	First Echo	Echo Rejection Type:	Standard
Curve 2:	None	Foam:	None	Target Thresh Mode:	Automatic	Echo Reject State:	Disabled
<input type="checkbox"/> Cyclic refresh		Turbulence:	None	Target Thresh Value:	25 %	Echo List Mode:	Distance
				Base Threshold:	8	Saved Reject Distance:	19.20 ft

A 'New Rejection Curve' button is highlighted with an arrow pointing to it from below. A 'Close' button is also visible.

Press to Initiate Function

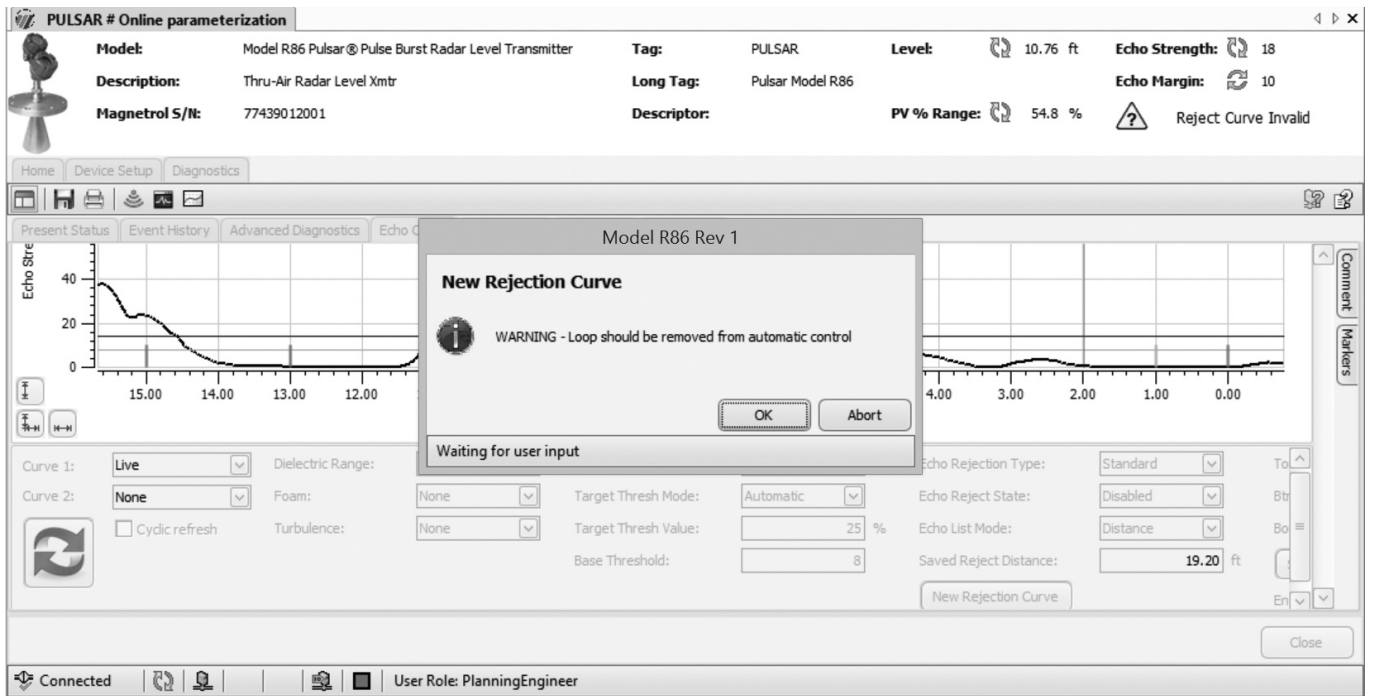

Click on NEXT at the loop warning message.

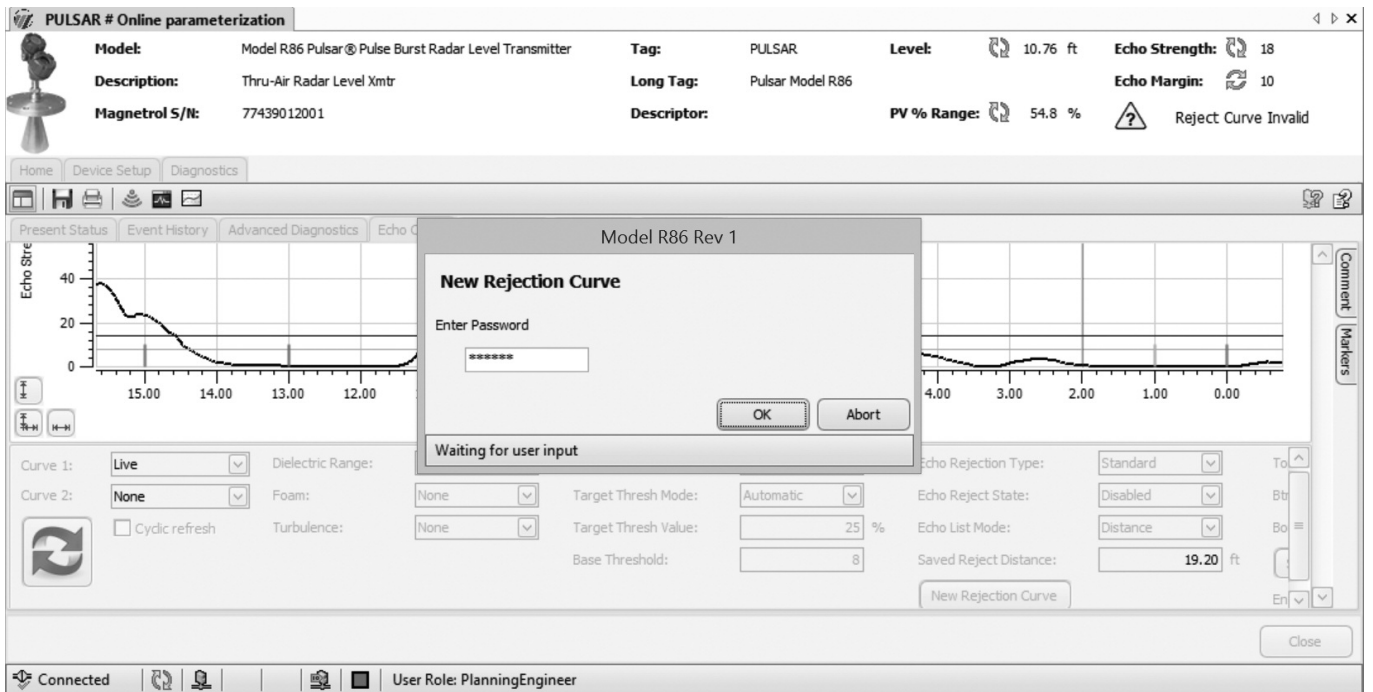

A password window will then appear. Click OK. The system calculates the curve, and then saves it. Click OK to confirm.

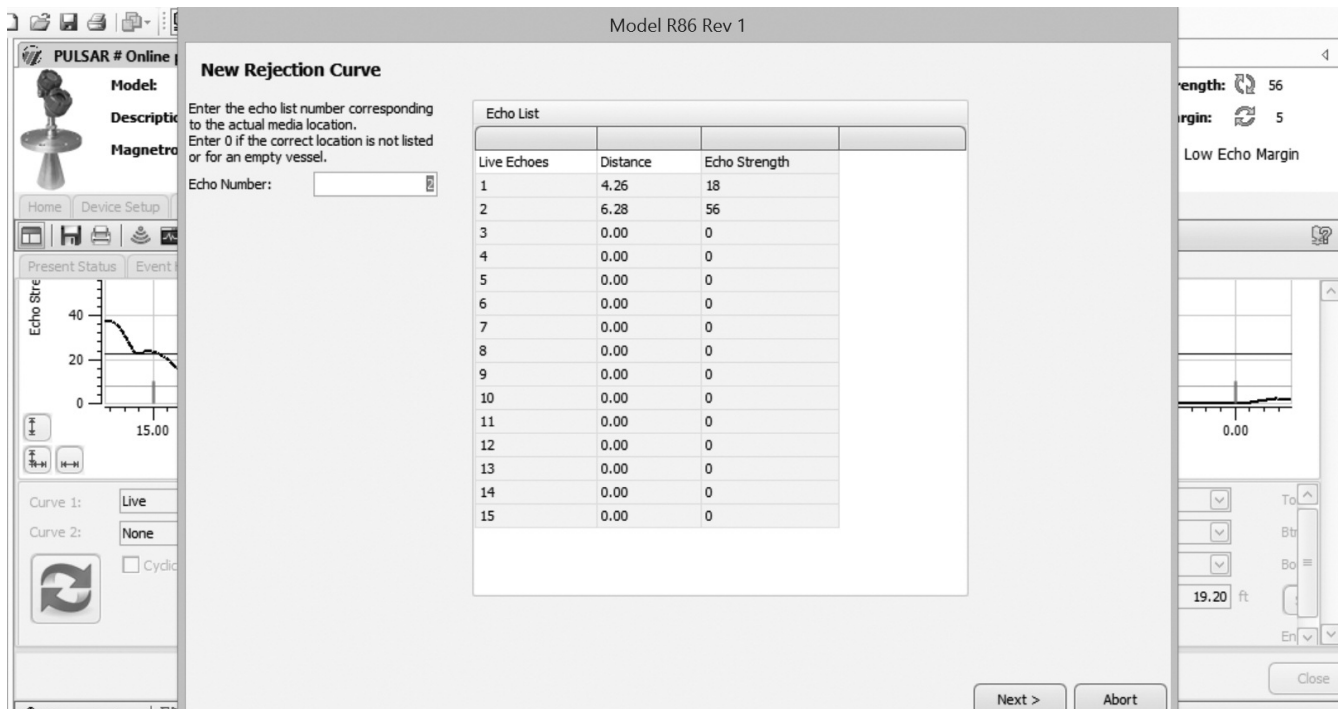

On the next screen, enter the actual location of the level to be measured. Press ENTER and then click on NEXT.

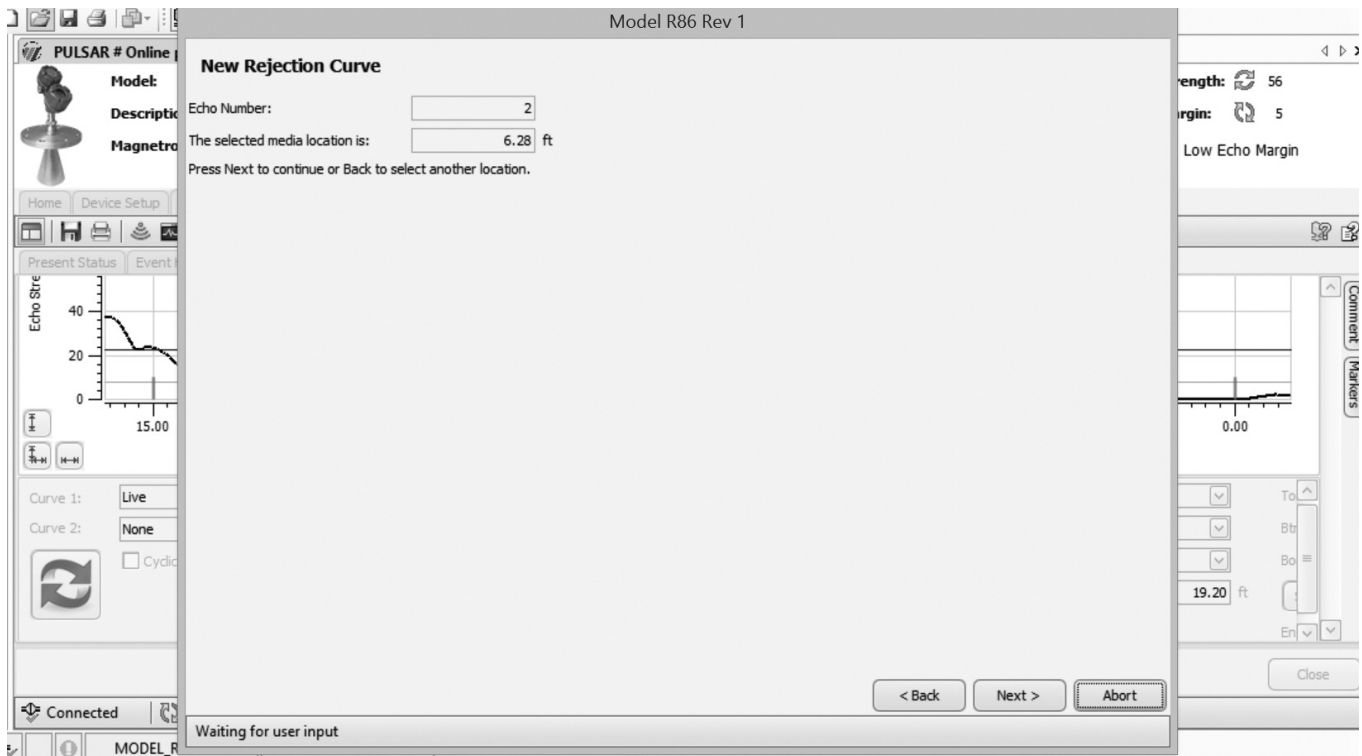

Press NEXT to confirm.

The Live Curve and Rejection Curve will then be displayed as shown in the screenshot below.

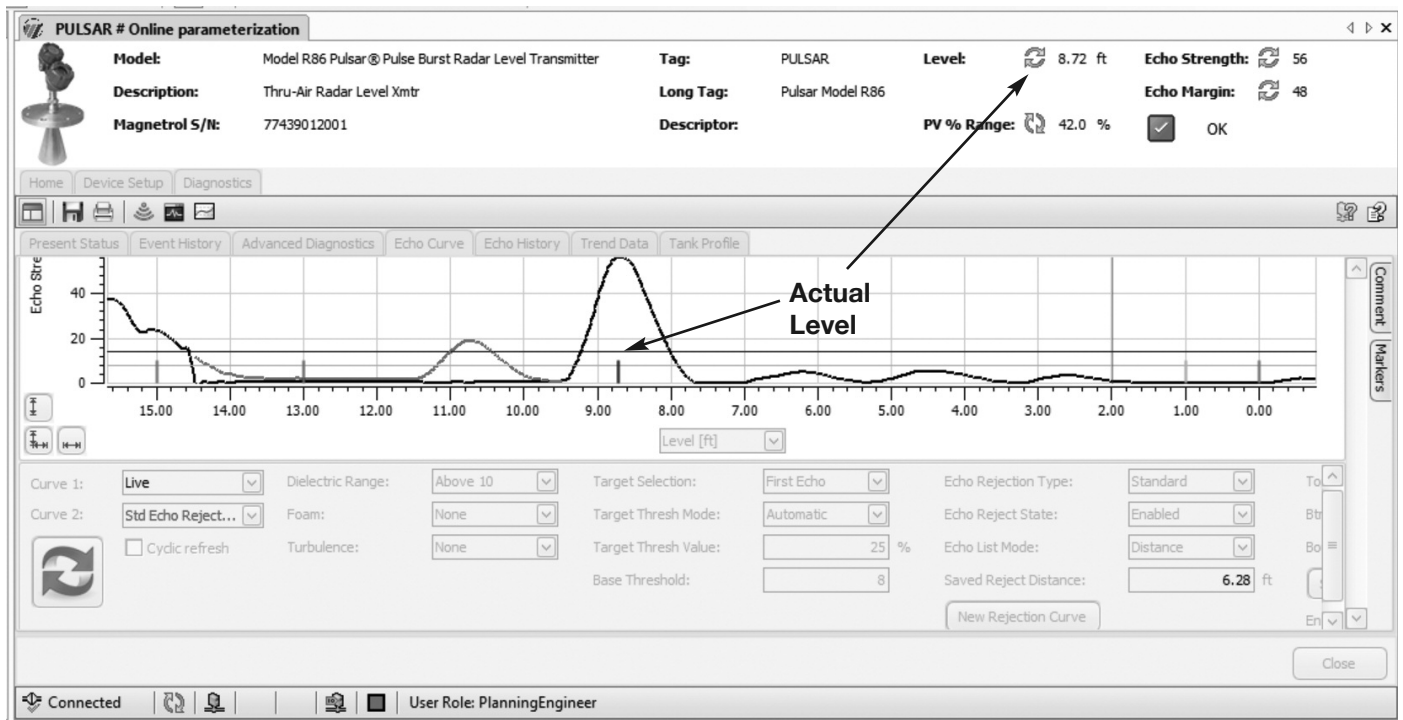

A warning screen is shown that the loop can be returned to automatic control.

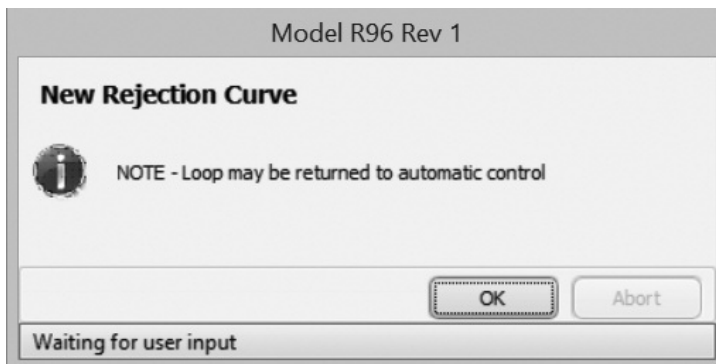

4.2 Custom Echo Rejection

INTRODUCTION

The Pulsar Model R86 has a very unique feature that allows for a user to modify a Standard Echo Rejection curve.

Custom Echo Rejection is a feature intended to allow a user to manually adjust the curve to account for undesirable waveform features (noise, disturbances, etc.) that may not have been captured by the initial Standard Echo Rejection curve.

For example, undesirable signals may occur if the original echo rejection curve was taken at a time when mixing blades were stopped in a particular location. If the blades then later stop in a different location, a false echo from the blade could then appear in the live echo curve. Custom Echo Rejection can then be used to modify the Standard Echo Rejection curve in order to ensure that all “false echoes” are cancelled out of the waveform.

The Custom Echo Rejection curve is offered in addition to the Standard Echo Rejection curve. Once a Custom Echo Rejection curve has been created, either curve is available for use by the user to reject unwanted echo echoes. The user has the ability to select which curve (or no curve) will be used for echo rejection.

Since the local display does not have the ability to concurrently display the live and rejection echo curves, the manipulation of the echo rejection curve will be done in the DD and DTM only. The ability to view the two curves graphed together is essential in determining how the rejection curve should be modified to provide the desired outcome.

When the Custom Echo Rejection curve is selected for use, the “New Rejection Curve” button will change to “Modify Rejection Curve”. Clicking on this button will guide a user through:

- modifying an existing echo in the custom curve
- copying an echo from the live curve to the custom rejection curve
- resetting a Custom Echo Rejection curve back to the original form from which it was taken (Standard Echo Rejection curve).

OPERATION

BEFORE STARTING: Note that changes to certain parameters cause the Echo Rejection profile to become invalid. Those parameter changes will invalidate both the Standard and the Custom rejection curves simultaneously, regardless of which echo rejection curve option is selected at the time. For example, making any changes to Gain parameters (Dielectric, Turbulence, Foam and Sensitivity) or Tank Height parameter will invalidate all Echo Rejection Curves whether Standard or Custom.

The Custom Echo Rejection curve can be modified in three ways:

1. Modify existing Echo

Changing the amplitude or width of an existing echo in the Custom Rejection Curve is the most typical use of this method. For example, it can be used to account for the variations in mixing blade operation. If mixing blades are stopped when the initial curve was created, the next time the blades stop they may be in a slightly different position. The new blade position can result in a slightly different position of its echo. Echoes from the blade will appear in the echo curve as slightly shifted to the left or right compared to the echo in the original curve. The amplitude may also be somewhat different. In that case, expanding the width of the existing echo, or changing its amplitude would create an echo rejection curve that encompasses both the original echo and the new echo locations.

2. Add an Echo

This is used to copy an echo from the live curve to the Custom Rejection Curve. This would be done in the event that a new echo was found in the live curve after the initial echo rejection curve had been saved.

NOTE: In the case where the level at the time was higher in the tank, saving a new entire echo rejection curve would result in a lower portion of the rejection curve being lost. Therefore, it is beneficial in that circumstance to be able to add the echo to the existing custom curve so that the lower portion of the curve is retained.

3. Reset Custom Curve

If the need arises to eliminate changes made during any of the previous modification procedures, Reset Custom Curve is used to reset the Custom Rejection Curve back to its original values.

PROCEDURES

Changing the widths and amplitude of an existing echo:

Modifying an existing echo in the custom rejection echo curve consists of the user identifying the desired echo and defining the changes to be made to that echo. The user begins the Customize Rejection Curve method in the DTM at Diagnostics/Echo Curve.

1. Ensure a Standard Echo Rejection has been captured before continuing (Standard Echo Rejection will appear as red curve on graph)

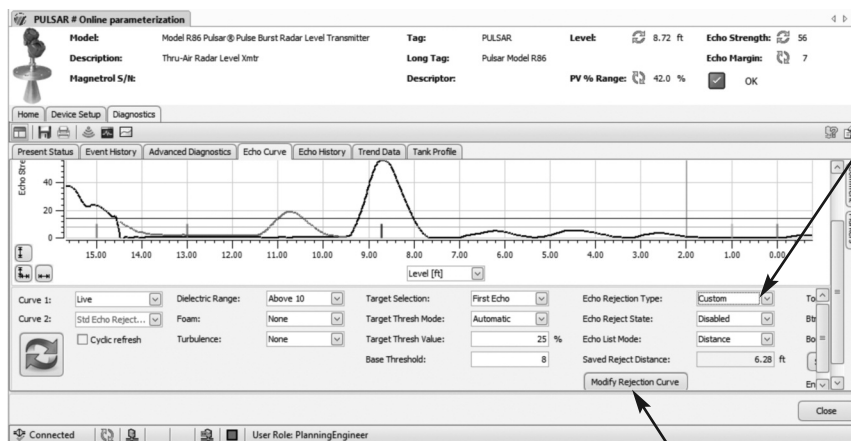

Change "Echo Rejection Type" from "Standard" to "Custom"

The "New Rejection Curve" button changes to "Modify Rejection Curve"; press button

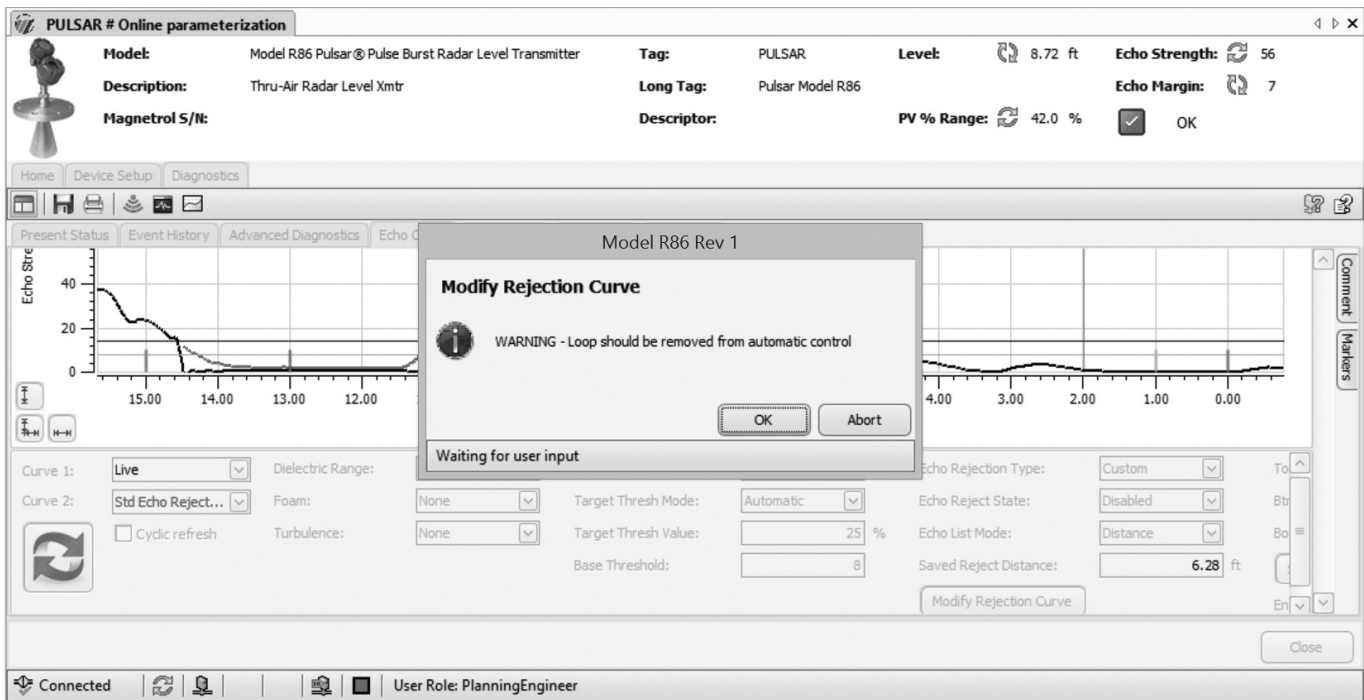

Click on NEXT at the loop warning message.

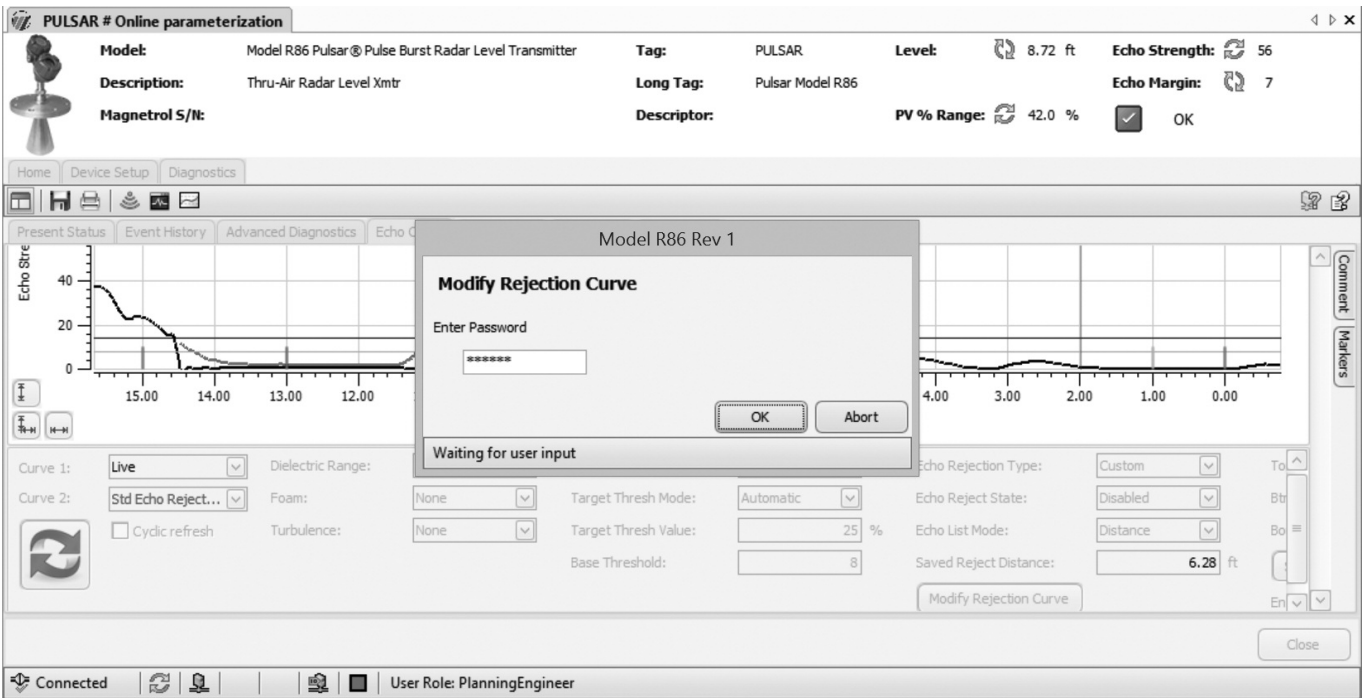

A password window will then appear. Click OK.

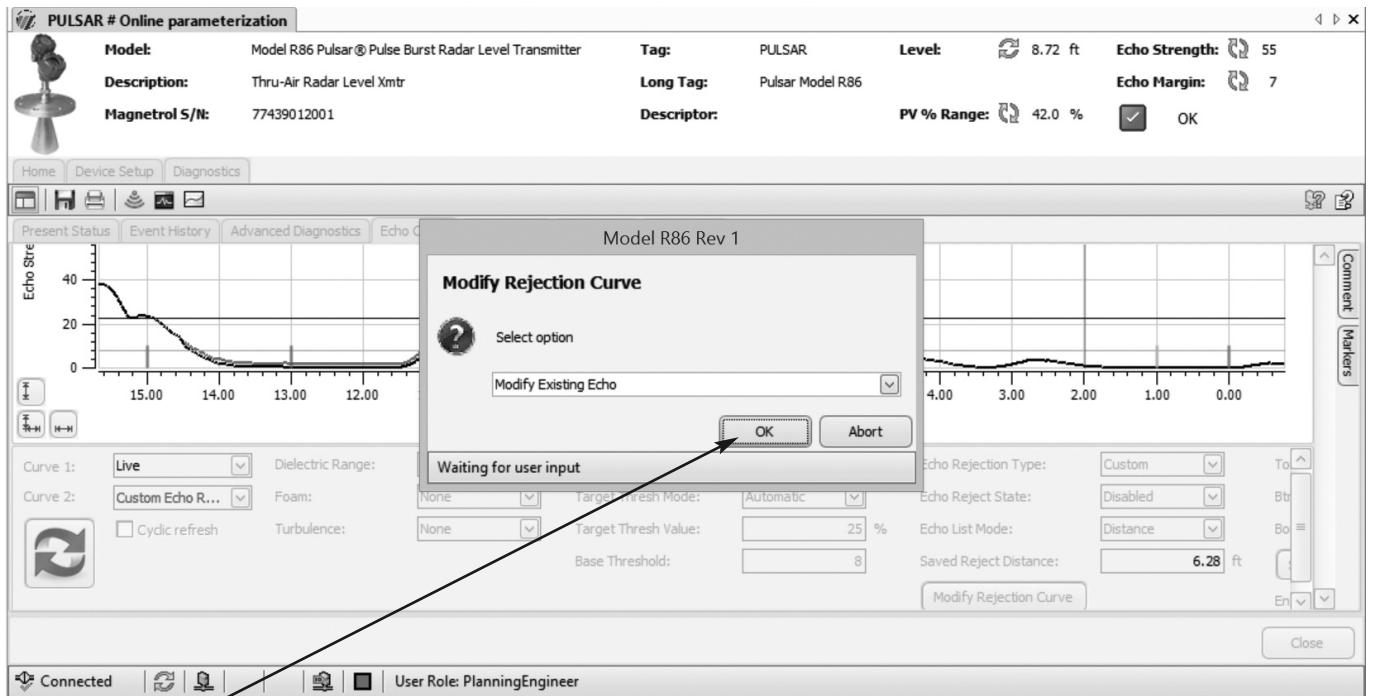

Click OK.

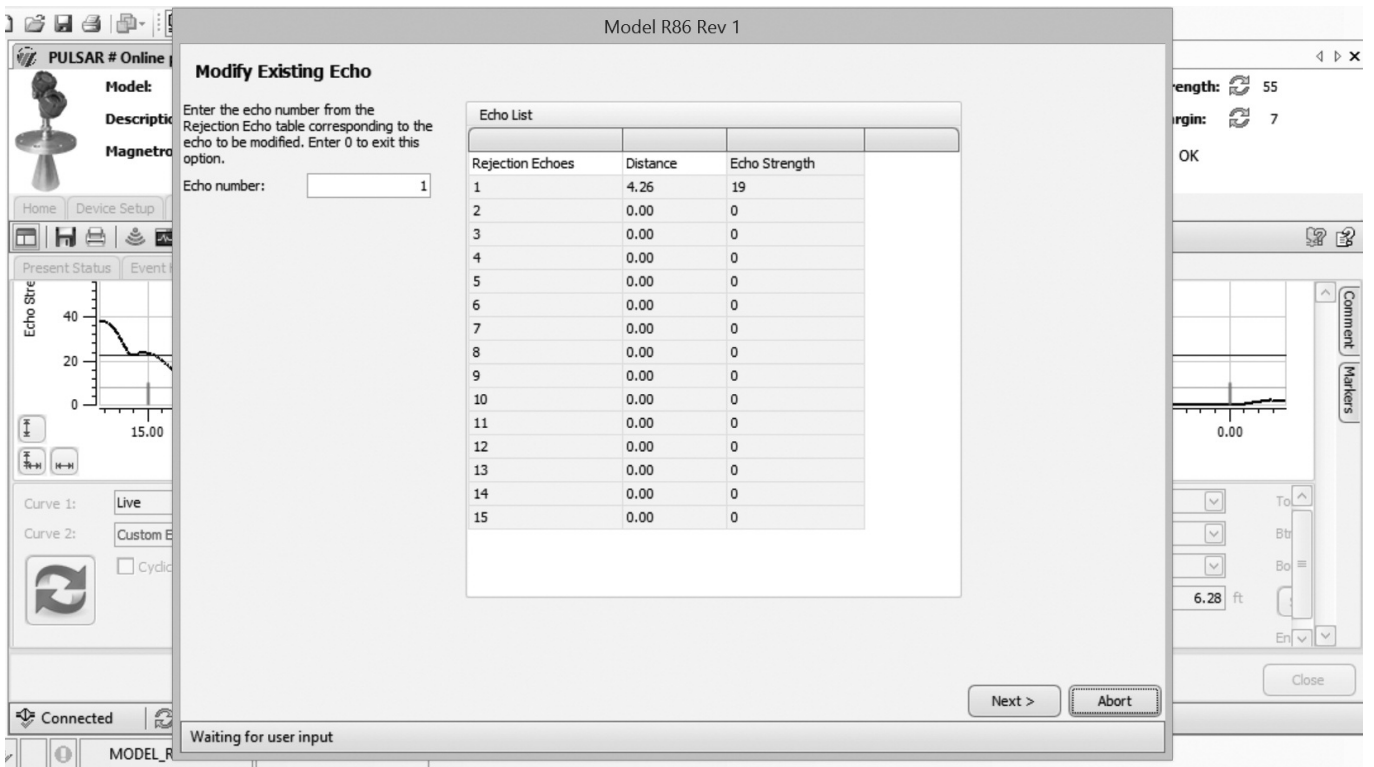

Upon presentation of the Rejection echo list (including the echo amplitudes), along with a display of the present level, select the desired false echo to be modified. (The distance to the echo must be smaller than the distance to the level echo).

Modify Existing Echo

Echo Number:

Echo 1 Location: ft



	Left Location	Strength	Right Location
	ft		ft
Original	3.78	19	4.66
Requested	3.78	19	4.66

Modify Existing Echo

Echo Number:

Echo 1 Location: ft

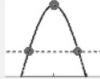

	Left Location	Strength	Right Location
	ft		ft
Original	3.78	19	4.66
Requested	<input type="text" value="3.50"/>	19	4.66

Revise left location and press ENTER. (Right location and/or strength can also be revised.)

Modify Existing Echo

Echo Number:

Echo 1 Location: ft



	Left Location	Strength	Right Location
	ft		ft
Original	3.46	19	4.66
Requested	3.46	22	4.80

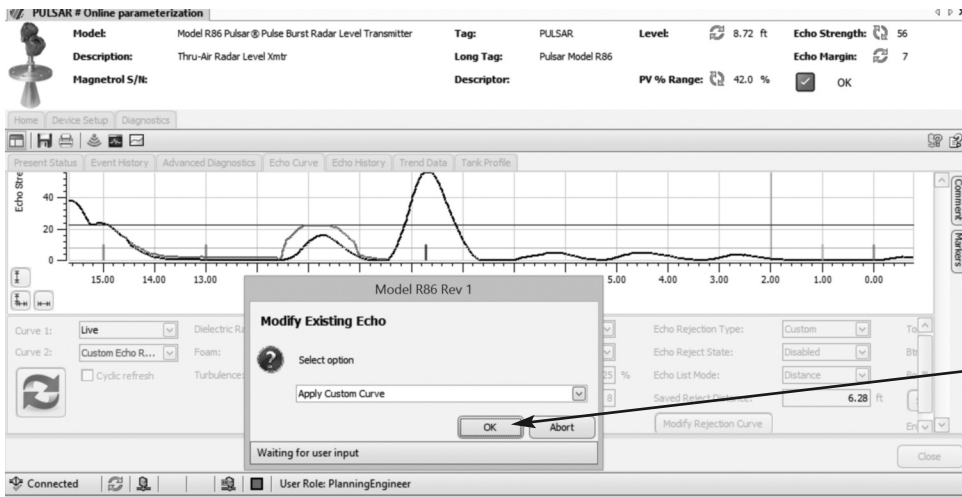

PULSAR # Online parameterization

Model: Model R86 Pulsar® Pulse Burst Radar Level Transmitter Tag: PULSAR Level: 8.72 ft Echo Strength: 56

Description: Thru-Air Radar Level Xmt Long Tag: Pulsar Model R86 Echo Margin: 7

Magnetrol S/It: Descriptor: PV % Range: 42.0 % OK

Home | Device Setup | Diagnostics

Present Status | Event History | Advanced Diagnostics | Echo Curve | Echo History | Trend Data | Tank Profile

Echo Strength vs. Level [ft] graph showing a peak at approximately 8.72 ft.

Model R86 Rev 1

Modify Existing Echo

Select option

Apply Custom Curve

OK Abort

Waiting for user input

Click OK.

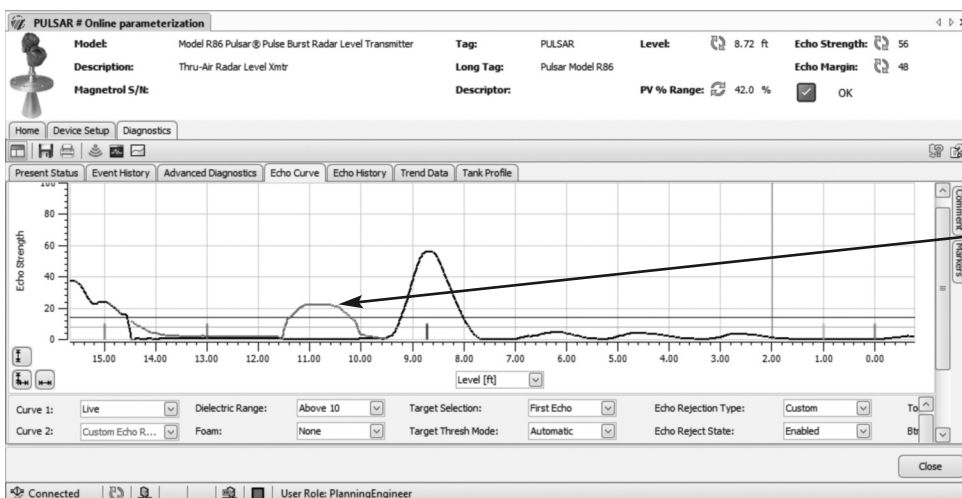

PULSAR # Online parameterization

Model: Model R86 Pulsar® Pulse Burst Radar Level Transmitter Tag: PULSAR Level: 8.72 ft Echo Strength: 56

Description: Thru-Air Radar Level Xmt Long Tag: Pulsar Model R86 Echo Margin: 48

Magnetrol S/It: Descriptor: PV % Range: 42.0 % OK

Home | Device Setup | Diagnostics

Present Status | Event History | Advanced Diagnostics | Echo Curve | Echo History | Trend Data | Tank Profile

Echo Strength vs. Level [ft] graph showing a peak at approximately 8.72 ft. A shaded area under the curve is labeled 'New Rejected Area'.

Level [ft]

Curve 1: Live Dielectric Range: Above 10 Target Selection: First Echo Echo Rejection Type: Custom To: ^

Curve 2: Custom Echo R... Foam: None Target Thresh Mode: Automatic Echo Reject State: Enabled Bt: v

New Rejected Area

4.3 Tank Profile

Introduction

Non-Contact radar transmitters are typically configured and commissioned with a static liquid level. Ideally, the installer will generate some level change after commissioning to verify proper operation, but rarely can one witness a complete fill and empty cycle of the vessel. Therefore, the transmitter configuration may not initially be optimized for the entire range of operation.

Although previous versions of Magnetrol transmitters contain troubleshooting options for recording and saving diagnostic information such as Data Log, Event History, and Echo History, none contains a way for the device to automatically capture pertinent information *for an entire fill and empty cycle*. As this complete cycle could take hours, days or even weeks to complete, having this information will confirm proper operation for a given configuration or can provide precious information about the transmitter performance at troublesome levels in the tank.

The information is stored in the transmitter, retrieved at a later time and evaluated by a qualified individual who will decide the next steps to take.

A few items to note:

1. The Tank Profile feature must be manually initiated. It is not an automatic feature.
2. The Tank Profile feature may be manually stopped at any time.
3. Before the feature starts capturing information, the transmitter configuration should be manually saved. This is not necessary for the operation of the feature but provides useful data for determining what configuration change may be warranted.
4. Although the ability to set up and run this feature will be available in all user interfaces (HART and FF LUI, DD and DTM), the results can only be graphically viewed in the corresponding DTM. For DD-based hosts, there is a DD method that will sequentially display the readings one level at a time.
5. The feature can be set to cover a smaller range than the entire tank. For example, some processes may only operate in a smaller range.
6. The increments can be set as a percentage of the Start/Stop range (Increment by %) or in Level/Distance units (Increment by Unit).
7. The information captured at each increment will be:
 - a. Time
 - b. Level
 - c. Distance
 - d. Echo Strength
 - e. Echo Margin
 - f. Loop Current (HART only)
 - g. Target Threshold
 - h. Level Ticks
 - i. BCSM state
8. The saved minimum and maximum Echo Strength and Echo Margin readings can be viewed in a graph in the Tank Profile menu.

SETUP

The Tank Profile can be initiated in the DTM in the following manner:

1. Use SET CLOCK button to ensure transmitter clock is set properly
2. Choose LIMIT UNITS of “Level” or “ % Range”
3. Choose INTERVAL, LIMITS and TIMES applicable to your needs.
4. TANK PROFILE STATUS will display “Off”, “Running” or “Completed”
5. Once device computer is used to configure transmitter it does not have to stay connected.
6. Connect computer at later date to download captured data for analysis.

From the DTM, Tank Profile is accessed from the Diagnostics/Tank Profile tabs

Hit Refresh to begin

Set clock, if desired

Limit Units = PV % Range.....Record Interval and Tank Profile units switch to “%”

Press "Save" icon upon completion of cycle to save all pertinent data

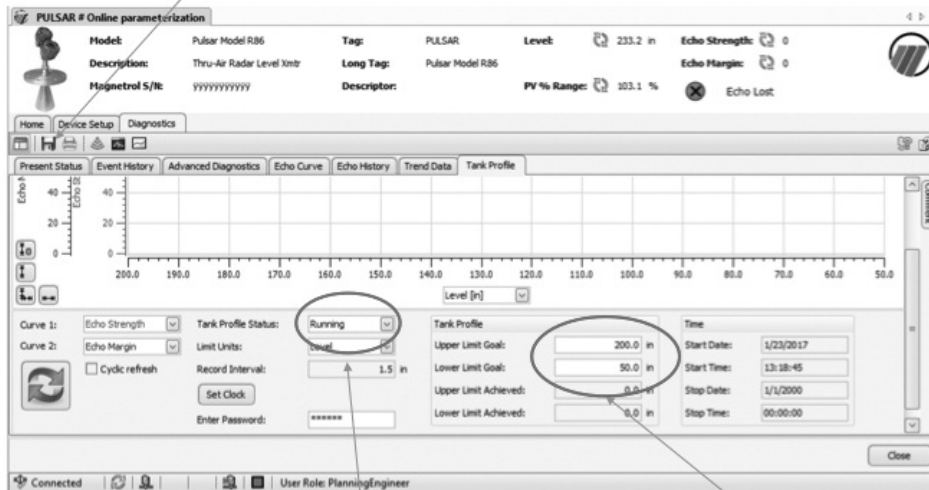

Status shown as "Running"

Designated limits shown

Progress can be conveniently viewed using the DTM

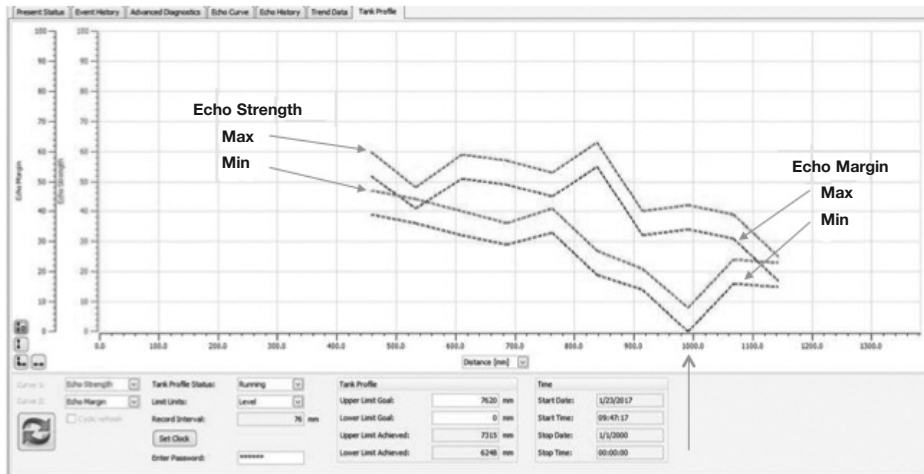

4.4 Echo Margin

Echo Margin is a unique parameter that, when used along with Echo Strength can be a very useful troubleshooting tool. Echo Strength is taken from the standard Signal-to-Noise calculation and is simply defined as:

"The amplitude of the Level echo in Echo Strength units (0-100)"

Echo Margin is defined as:

"A numeric value that is related to the strength of the target peak relative to the Level Threshold or competing waveform features, i.e. "noise."

The Echo Margin value (for the typical First Echo mode) is calculated as the difference of the False target-to-Threshold OR the Level target-to-Threshold whichever is SMALLER.

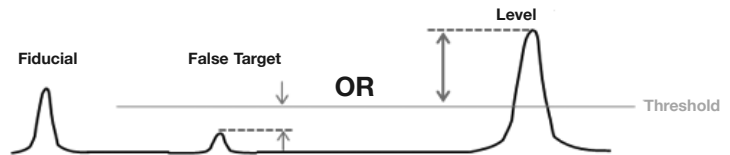

By reporting the SMALLER value, Echo Margin does a better job of reporting which issue is most likely to become a problem:

- False Target- if this echo becomes large enough to rise above the Threshold it will be mistakenly reported as the Level.
- Level Echo- if this echo becomes small enough to fall below the Threshold the transmitter will report Loss of Echo.

Always examine both Echo Strength and Echo Margin values. Increasing a Gain parameter (Dielectric, Turbulence, Foam or Sensitivity) will increase the amplitude of all echoes in the radar scene. If, after increasing a Gain parameter, the Echo Strength increases but the Echo Margin decreases a False Target is reaching closer to the Threshold (see drawing above). If the False Target reaches above the Threshold it will be detected as a valid Level echo and will be incorrectly reported as Level. In this case running Echo Rejection will eliminate the False Target and increase the Echo Margin value. Echo Margin values >20 are a good goal.

4.5 Automated Echo Capture

Unattended Echo Capture

One of the ways the Model R86 simplifies an often complex technology like Radar, is to improve the speed at which a user can turn around a problem and get the device back online. Minimizing down time is the ultimate goal of any device.

One of the most important tools used to troubleshoot a Radar application or optimize a transmitter configuration is the echo curve. This graphical representation of a Radar echo speaks volumes to those trained to interpret them. It is like a snapshot in time of the health of the transmitter. It is actually like seeing inside of the tank. However, the challenge with echo curves is acquiring them in a timely fashion. Unfortunately, most problems develop when there is a skeleton crew and no one watching this particular vessel. By the time an instrument technician can investigate, the alarm has cleared and no one understands why it occurred or, more importantly, when it will happen again. Since an echo curve is so important in troubleshooting the device, it is critical to capture the curve at the instant a problem occurs. Too often this means connecting a laptop and gathering information AFTER the first signs of the problem, which is obviously not ideal.

The advanced Pulsar Model R86 design is very effective at addressing this issue. This advanced design allows the transmitter to automatically capture an Echo Curve based on an Event (such as Loss of Echo) or Time (using the on-board clock).

It is shipped from the factory so an echo curve is automatically captured based on key Events. The transmitter has the ability to store a number of echo curves in its on-board memory. These echo curves can then be downloaded to a laptop running software such as PACTware and reviewed in Diagnostics/Echo History tab. If necessary, the user can email this information to the factory for expert assistance in troubleshooting. This enables the problem to be resolved much more quickly, minimizing possible down time.

A number of points should be made in this example:

- Curve 1 is showing the current Live echo
- Curve 2 is showing “History 9”— the 9th echo stored in memory which was automatically captured at 5:40 p.m. on 4/5/2017
 - This echo capture was triggered by the “Low Echo Margin” diagnostic

SETUP

NOTE: The transmitter is shipped from the factory configured to automatically capture Echo Curves based on “Events” with ALL Events being enabled.

Automated Echo Capture is configured in the DTM in the following manner:

Open DTM to Diagnostics/Echo History

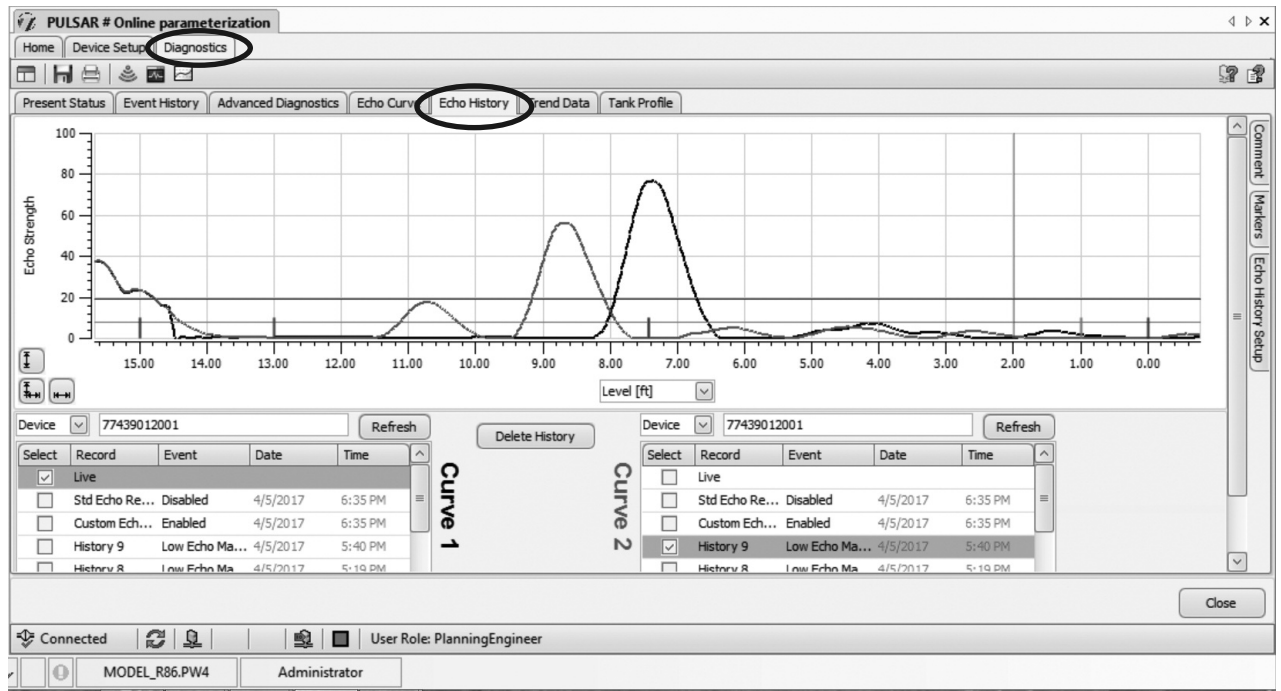

4.6 Event History

Although Event History has been included (and found to be very useful) in other Magnetol devices, it has been improved in the Model R86.

Event History becomes the main repository of all key Diagnostic and Configuration data. It now displays a history of the 20 most recent diagnostic indicators and configuration changes. For each event, the time when the event occurred and the duration of the event are shown. The table of history indicators displays the most recent indicator at the top with preceding indicators in descending order.

NOTE: A “+” suffix denotes the event remains active

Key Features:

- 20 lines of Event information
- All Diagnostic and Configuration info
- Now 7 columns of data
- Item #
- Event name
- Date
- Time
- Duration
- Value1
- Value2

Value1 and Value2 entries have various meanings depending on the Event. (A comprehensive explanation of these entries is included in this section.) It is highly recommended to Set Clock (in transmitter) if actual Dates and Times are not shown.

(Although Event History can be viewed via the Local User Interface, the DTM offers a more complete view of the information.)

Press “Refresh Event History” upon opening the screen.

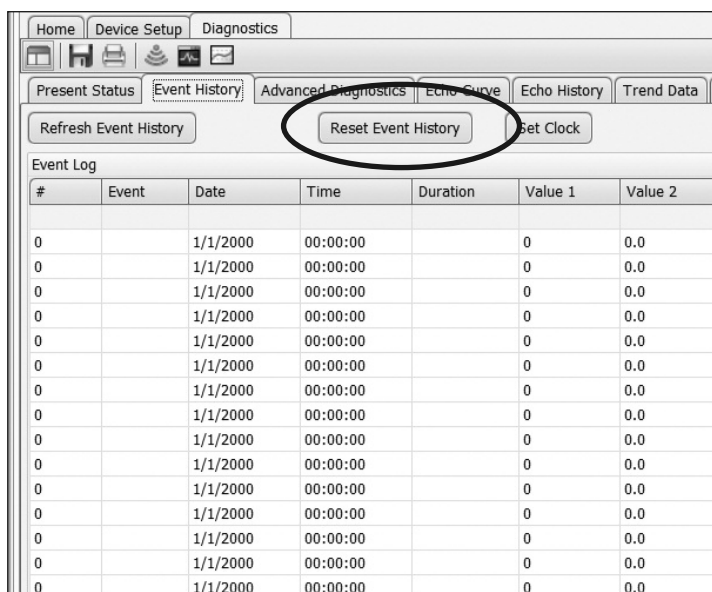

+ indicates event is active

#	Event	Date	Time	Duration	Value1	Value2
20	BC Level	2017-01-18	13:05:21	022:34:12+	12	18.0
19	Echo Reject State	2017-01-15	11:14:01	000:00:00	0	2.0
18	Std. Echo Rejection	2017-01-15	11:10:59	000:00:00	0	24.1
17	Foam	2017-01-15	11:08:39	000:00:00	1	35.0
16	Echo Curve	2017-01-15	09:41:45	000:00:00	2	83.2
15	Echo Lost	2017-01-15	09:41:15	000:87:45	0	83.2
14	Foam	2017-01-15	09:40:13	000:00:00	0	9.0
13	Max. Jump Exceeded	2017-01-12	01:26:41	000:00:49	32	118.5
12	Echo Reject State	2017-01-12	01:25:23	070:02:13	20	27.4
11	Foam	2017-01-12	01:25:23	000:00:00	2	88.0
10	BC Level	2017-01-08	15:51:20	000:17:49	1	33.1
9	Echo Reject State	2017-01-08	15:51:05	000:00:00	0	2.0
8	Echo Curve	2017-01-08	15:32:46	000:00:00	7	29.5
7	Low Echo Margin	2017-01-08	15:32:16	000:00:00	5	29.5
6	BC Level	2017-01-08	15:31:10	028:35:45	01	42.1

7 LOW ECHO MARGIN

Value 1 - EM value when captured
Value 2 - Level value when captured

Echo History – Value1/Value2 Look-up Table

Event	Value1	Value2
ALL DIAGNOSTIC INDICATORS (unless otherwise noted below)	0 = No value (unused)	Level value when captured
Analog Board Error	Error Code	0 = No value (unused)
Analog Output Error	Measured current	Expected current
Boundary Condition State (BCS) changes, Echo Lost and Inferred Level	XX- 2-digit value 1st digit = Beginning state 2nd digit = Ending state Based on following codes: 0 = Initialization 1 = Level (normal) 2 = Empty 3 = Full 4 = Echo Missing 5 = Echo Lost 6 = No Fiducial 7 = Restart	Level value when captured
Echo Curve (automated capture)	Capture based on: 12 - Too Many Echoes 14 - Echo Lost 17 - High Volume Alarm 18 - High Flow Alarm 28 - Inferred Level 33 - Max Jump Exceeded 34 - Low Echo Margin	Level value when captured
Echo Lost	See BCS changes	
High Electrical Temp	0 = No value (unused)	Temp when activated
High Surface Velocity	Value when activated	Level value when captured
Inferred Level	See BCS changes	
Low Echo Margin	Value when activated	Level value when captured
Low Electrical Temp	0 = No value (unused)	Temp when activated
Low Supply Voltage	Extrapolated terminal Lower voltage	Extrapolated terminal Upper voltage
Max. Jump Exceeded	Beginning Level value	Ending Level value
Reject Curve Invalid	0 = No value (unused)	0 = No value (unused)
Reset Max/Min Temperatures	Max Temp before reset	Min Temp before reset
Sweep Time Error	DAC setting	Sweep width
Too Many Echoes	Number of Echoes found	Level value when captured

Configuration Parameters

Event	Value1	Value2
# Run Average	Old value	New Value
4mA (LRV)	Old value	New value
20mA (URV)	Old value	New value
Base Threshold	Old value	New value
Bottom Blocking Distance	Old value	New value
Custom Echo Rejection	0 = No value (unused)	Level value when captured
Dielectric	0 = 1.4–1.7 1 = 1.7–3.0 2 = 3.0–10 3 = >10	Corresponding Echo Strength

Configuration Parameters (continued)

Event	Value1	Value2
Echo Rejection Type 2 = Standard Echo Rejection 3 = Custom Echo Rejection	Old value	New Value
Echo Reject State	Old Value 0 = Off 1 = Disabled 2 = Enabled	New Value
FME Distance Threshold	Old value	New Value
Foam	0 = None 1 = Light 2 = Medium 3 = Heavy	Corresponding Echo Strength
HART Poll address	Old value	New value
Level Trim	Old value	New value
Max Level Jump	Old value	New value
Max Surface Velocity	Old value	New value
Passwords (Date/Time only)	0 = No value (unused)	0 = No value (unused)
Rate of Change	Old value 0 = <5 in/min (<130mm/min) 1 = 5–20 in/min (130-500mm/min) 2 = 20–60 in/min (500–1500mm/min) 3 = >60 in/min (>1500mm/min)	New value
Sensitivity	Value	Corresponding Echo Strength
Standard Echo Rejection	0 = No value (unused)	Level value when captured
Stillwell ID	Old value	New value
Tank Height	Old value	New value
Target Selection	Old value 1 = First Echo 2 = Largest Echo 3 = First Moving Echo	New value
Target Threshold Mode	Old value 1 = Automatic 2 = Fixed	New value
Target Threshold Value	Old value Automatic = % of Peak Max Fixed = Value in Eng. Units	New value
Top Blocking Distance	Old value	New value
Turbulence	0 = None 1 = Light 2 = Medium 3 = Heavy	Corresponding Echo Strength
TVG End Location	Old value	New value
TVG End Value	Old value	New value
TVG Start Location	Old value	New value
TVG Start Value	Old value	New value

Complete Listing of Diagnostic Indicators including Analog Board Errors

Error Code	Diagnostic	Explanation
0	OK	
1	Software Error	Instruction execution traversed an incorrect path
2	RAM Error	run-time volatile memory test failed
3	ADC Error	Run-time analog-to-digital converter test failed
4	EEPROM Error	Unrecoverable checksum error in non-volatile memory
5	Analog Board Error	Delay-locked loop malfunction
6	Analog Output Error	Measured loop current differs from commanded value
7	Spare	
8	Default Params	All parameters reset to default values
9	Spare	
10	Sweep Time Error	Analog Board sweep time error
11	Spare	
12	Too Many Echoes	Excessive number of waveform features are possible echoes
13	Safe Zone Alarm	Level is above Safe Zone end
14	No Echoes	Echo from upper surface missing for longer than Echo Loss Delay
15	Spare	
16	Config Conflict	Configuration conflict caused by incompatible parameter selections
17	High Volume Error	Calculated Volume exceeds maximum for vessel or custom table
18	High Flow Error	Calculated Flow exceeds maximum for flume or custom table
19	Spare	
20	Initializing	System warming up, distance measurement not yet valid
21	Config Changed	A parameter(s) has recently been modified from the User Interface
22	Spare	
23	High Electrical Temp	Present electronics temperature above maximum
24	Low Electric Temp	Present electronics temperature below minimum
25	Calibration Required	Distance calibration parameters are at default values
26	Echo Rejection Invalid	Previously stored Echo Rejection Curve invalidated by parameter change
27	Spare	
28	Inferred Level	Typically this is caused when the Level target has been lost or has entered either the Top or Bottom Blocking Distance zones. If in the Top or Bottom Blocking Distance zones the transmitter will read Full (Top) or Empty (Bottom). The Level reading (and mA value) will never be higher than the value related to the Top Blocking Distance or lower than the value related to the Bottom Blocking Distance.
29	Adjust Analog Output	Loop trim parameters are at default values
30	Totalizer Data Lost	Totalizer data has been lost, restarted from zero
31	Low Supply Voltage	Power supply voltage inadequate to prevent brownout or reset
32	Spare	
33	Max Jump Exceeded	Transmitter has jumped to an echo that exceeds the Max Distance Jump value from the previous echo.
34	Marginal Echo	Signal Margin is less than allowable minimum
35	High Surface Velocity	The measured Surface Velocity is greater than the Max Surface Velocity value derived from the Rate of Change parameter.
36	Spare	
37	Seq Record	Instruction execution traversed a correct but unexpected path (formerly System Warning)

IMPORTANT

The Model R86 transmitter is not serviceable in the field. Return to the factory for repair or replacement.

SERVICE POLICY

Owners of Magnetrol products may request the return of a control; or, any part of a control for complete rebuilding or replacement. They will be rebuilt or replaced promptly. Magnetrol International will repair or replace the control, at no cost to the purchaser, (or owner) **other than transportation cost** if:

- a. Returned within the warranty period; and,
- b. The factory inspection finds the cause of the malfunction to be defective material or workmanship.

If the trouble is the result of conditions beyond our control; or, is **NOT** covered by the warranty, there will be charges for labour and the parts required to rebuild or replace the equipment.

In some cases, it may be expedient to ship replacement parts; or, in extreme cases a complete new control, to replace the original equipment before it is returned. If this is desired, notify the factory of both the model and serial numbers of the control to be replaced. In such cases, credit for the materials returned, will be determined on the basis of the applicability of our warranty.

No claims for misapplication, labour, direct or consequential damage will be allowed.

RETURNED MATERIAL PROCEDURE

So that we may efficiently process any materials that are returned, it is essential that a "Return Material Authorisation" (RMA) form will be obtained from the factory. It is mandatory that this form will be attached to each material returned. This form is available through Magnetrol's local representative or by contacting the factory. Please supply the following information:

1. Purchaser Name
2. Description of Material
3. Serial Number and Ref Number
4. Desired Action
5. Reason for Return
6. Process details

Any unit that was used in a process must be properly cleaned in accordance with the proper health and safety standards applicable by the owner, before it is returned to the factory.

A material Safety Data Sheet (MSDS) must be attached at the outside of the transport crate or box.

All shipments returned to the factory must be by prepaid transportation. Magnetrol **will not accept** collect shipments.

All replacements will be shipped Ex Works.

BULLETIN N°: BE 58-603.2
EFFECTIVE: JULY 2017
SUPERSEDES: June 2017

UNDER RESERVE OF MODIFICATIONS



www.magnetrol.com

BENELUX FRANCE	Heikensstraat 6, 9240 Zele, België -Belgique Tel. +32 (0)52.45.11.11 • Fax. +32 (0)52.45.09.93 • E-Mail: info@magnetrol.be
DEUTSCHLAND	Alte Ziegelei 2-4, D-51491 Overath Tel. +49 (0)2204 / 9536-0 • Fax. +49 (0)2204 / 9536-53 • E-Mail: vertrieb@magnetrol.de
INDIA	B-506, Sagar Tech Plaza, Saki Naka Junction, Andheri (E), Mumbai - 400072 Tel. +91 22 2850 7903 • Fax. +91 22 2850 7904 • E-Mail: info@magnetrolindia.com
ITALIA	Via Arese 12, I-20159 Milano Tel. +39 02 607.22.98 • Fax. +39 02 668.66.52 • E-Mail: mit.gen@magnetrol.it
RUSSIA	Business center "Farvater", Ruzovskaya Street 8B, office 400A, 190013 St. Petersburg Tel. +7 812 320 70 87 • E-Mail: info@magnetrol.ru
U.A.E.	PO Box 261454 • JAFZA LIU FZS1 – BA03, Jebel Ali Tel. +971 4 880 63 45 • Fax +971 4 880 63 46 • E-Mail: info@magnetrol.ae
UNITED KINGDOM	Unit 1 Regent Business Centre, Jubilee Road Burgess Hill West Sussex RH 15 9TL Tel. +44 (0)1444 871313 • Fax +44 (0)1444 871317 • E-Mail: sales@magnetrol.co.uk