

VMZ induQ®



Your advantages

Series	VMZ
	<ul style="list-style-type: none"> • Cost optimised plastic version • High measuring accuracy • Compact lightweight construction, low space requirement • Delivery including works calibration certificate

Type	VMZ030	VMZ081	VMZ082	VMZ153	VMZ204	VMZ205	VMZ256
Characteristics							
Nominal diameter	DN 3	DN 8	DN 8	DN 15	DN 20	DN 20	DN 25
Process connection	G $\frac{3}{8}$ B male	G $\frac{1}{2}$ B male	G $\frac{1}{2}$ B male	G $\frac{3}{4}$ B male	G 1 B male	G 1 B male	G 1 $\frac{1}{4}$ B male
Inner diameter	3 mm	8 mm	8 mm	14 mm	18 mm	18 mm	25 mm
Flow range	0.1...2 l/min	0.25...5 l/min	1...20 l/min	2.5...50 l/min	5...100 l/min	10...200 l/min	12.5...250 l/min
Accuracy*	±1 % of reading						
Repeatability	±1 %						
Response time	<100 ms						
Signal output starting from	0.05 l/min	0.1 l/min	0.25 l/min	1 l/min	2 l/min	4 l/min	5 l/min
Max. Flow rate	2.5 l/min	6 l/min	25 l/min	60 l/min	120 l/min	240 l/min	300 l/min
Medium / min. conductivity of medium	Water and other conductive liquids / 20 μ S/cm						
Medium temperature	-10...60 °C (non-freezing)						
Ambient temperature	5...60 °C						
Max. pressure rating	10 bar at 20 °C, 8 bar at 40 °C, 6 bar at 60 °C						
Indications	Red LED = power, green LED = flow rate						
Degree of protection EN 60529	IP65 (with attached cable socket)						
Output signals							
→ Pulse rate**	10 000 pulses/l	4000 pulses/l	1000 pulses/l	400 pulses/l	200 pulses/l	100 pulses/l	80 pulses/l
→ Resolution**	0.1 ml/pulse	0.25 ml/pulse	1 ml/pulse	2.5 ml/pulse	5 ml/pulse	10 ml/pulse	12.5 ml/pulse
→ Signal shape	Frequency signal, square wave, can be connected as PNP or NPN open collector pulse duty ratio 50:50						
→ Signal current	Max. 25 mA						
Electrical data							
Electrical connection	4 pin plug connector M12 x 1						
Power supply	24 VDC (±15 %) or 12 VDC (±15 %)						
Power consumption	0.6 W						
Electrical protection measures	Short-circuit proof and polarity protection						

* Test conditions: Water 23 °C

** Other pulse rates / resolutions available on request

optional output signal with lower frequency, designed specifically for connection to digital PLC inputs

Typical pressure drop VMZ030

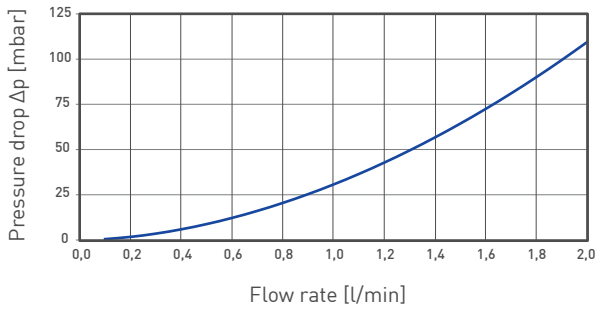

Typical pressure drop VMZ081 / VMZ082

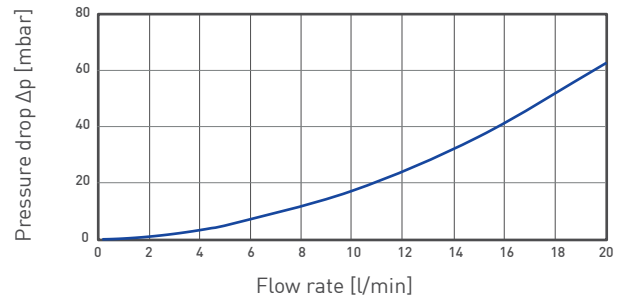

Typical pressure drop VMZ153

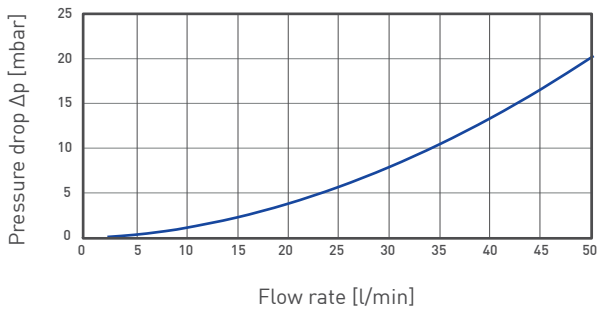

Typical pressure drop VMZ204 / VMZ205

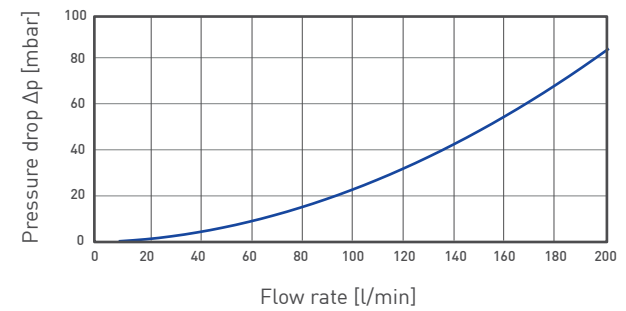

Typical pressure drop VMZ256

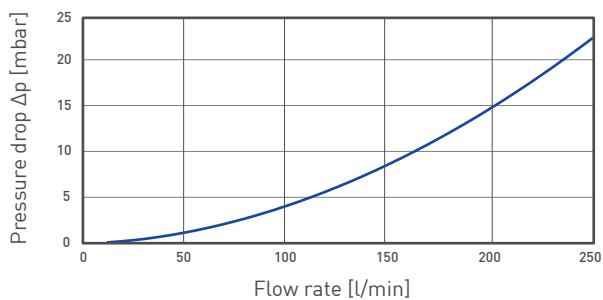

VMZ03 / VMZ08 / VMZ15 / VMZ20

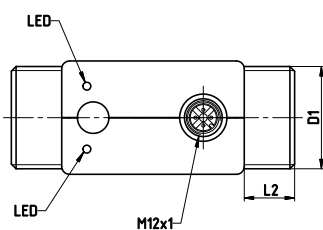
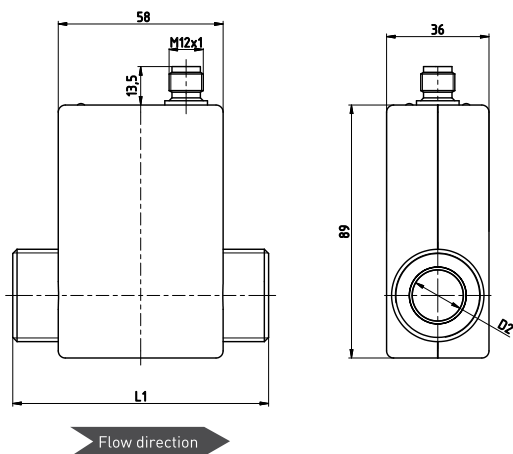

VMZ25

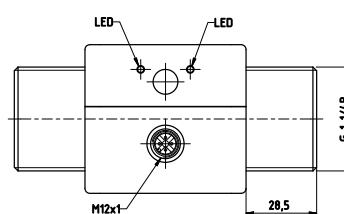
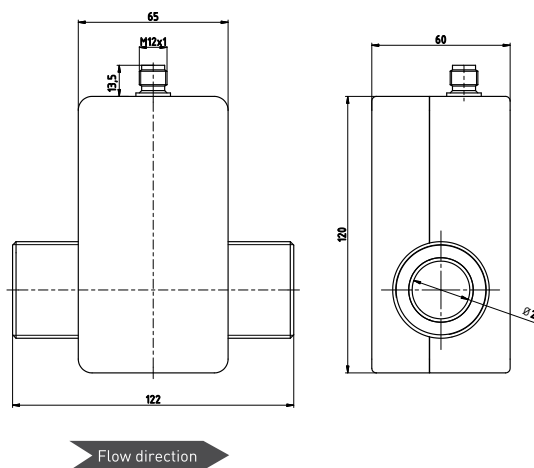

Dimensions [mm]

Type	L1	L2	D1	D2
VMZ030	85	13.3	G $\frac{3}{8}$ B	Ø 3
VMZ081	85	13.3	G $\frac{1}{2}$ B	Ø 8
VMZ082	85	13.3	G $\frac{1}{2}$ B	Ø 8
VMZ153	90	16	G $\frac{3}{4}$ B	Ø 14
VMZ204	90	16	G 1 B	Ø 18
VMZ205	90	16	G 1 B	Ø 18

Materials

Not in contact with fluid	
Housing	ABS
In contact with fluid	
Electrodes and earthing rings	Stainless steel 1.4404 or Hastelloy C ^{®*}
Measuring pipe and process connections	POM or PVDF
O-rings	EPDM

* Available for VMZ030, VMZ081, VMZ082

Order code				
Flow range				
0.1...2 l/min	VMZ030S1			211
0.25...5 l/min	VMZ081S1			310
1...20 l/min	VMZ082S1			320
2.5...50 l/min	VMZ153S1			430
5...100 l/min	VMZ204S1			540
10...200 l/min	VMZ205S1			550
12.5...250 l/min	VMZ256S2			660
Measuring pipe				
POM		DE		
PVDF		PE		
POM, Electrodes and earthing rings made of Hastelloy C®		DB*		
PVDF, Electrodes and earthing rings made of Hastelloy C®		PB*		
Power supply				
12 VDC			G14	
24 VDC			G24	
Example order number	VMZ030S1	DE	G14	211



* Available for VMZ030, VMZ081, VMZ082

**BEST
SELLER**

Type	Order number			
VMZ Flow range 0,25...5 l/min, Measuring pipe: PVDF, 24 VDC	VMZ081S1	PE	G24	310
Flow range 1...20 l/min, Measuring pipe: PVDF, 24 VDC	VMZ082S1	PE	G24	320
Flow range 2,5...50 l/min, Measuring pipe: PVDF, 24 VDC	VMZ153S1	PE	G24	430

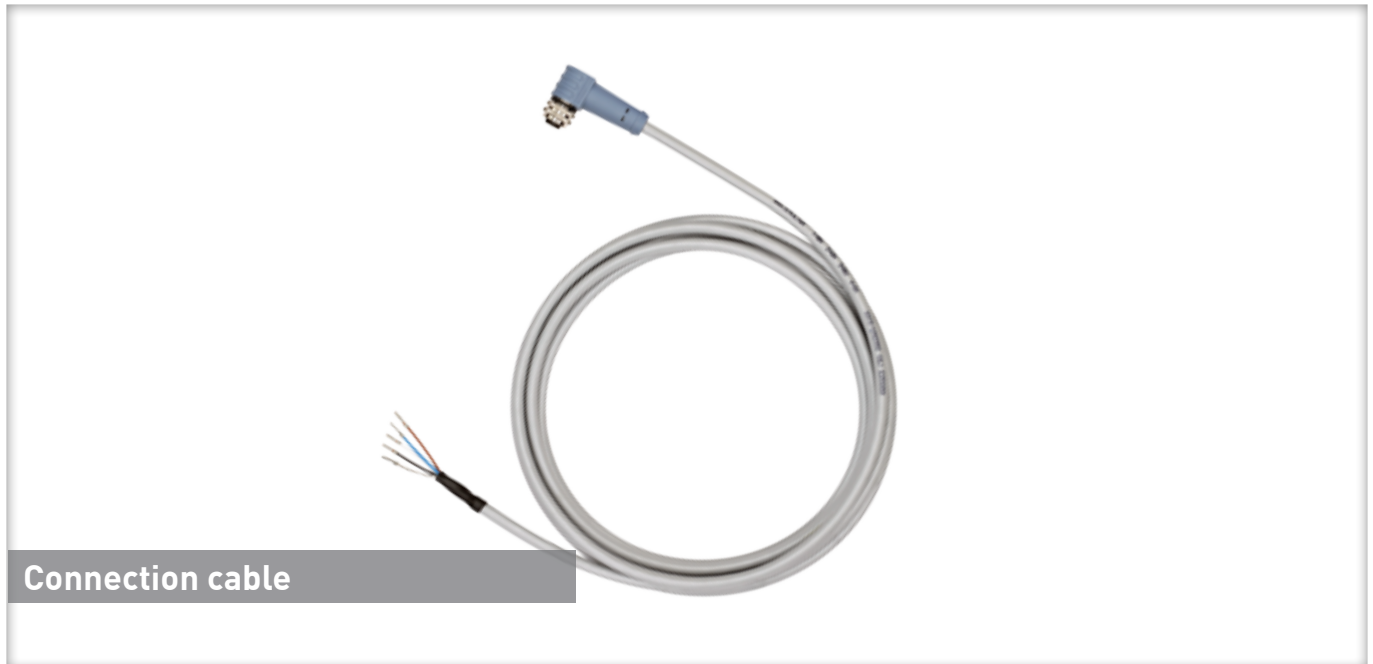
Accessories

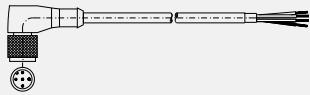

Order code			
Accessories		Length	Order number
	Connection cable with 4-pin cable socket M12 x 1, angle type moulded lead, sheathing material PUR, shielded, (Tmax = 80 °C), UL-approval	3 m	XVT2053
		5 m	XVT2009
		10 m	XVT2070
	4 pin cable socket M12 x 1 angle type, unassembled		VT1331